

# VEHICLE MOVEMENT STREET LIGHT WITH AUTOMATIC LIGHT SENSING

*by*

Name	Roll No.	Registration No:
<b>ANIKESH KUNDU</b>	<b>11700314013</b>	<b>141170110195</b> of 2014-2015
<b>RAUNAK KR SINGH</b>	<b>11700314067</b>	<b>141170110249</b> of 2014-2015
<b>CHANDAN KUMAR RAM</b>	<b>11700314032</b>	<b>141170110214</b> of 2014-2015
<b>SUSITA SAHA</b>	<b>11700314115</b>	<b>141170110297</b> of 2014-2015

*A comprehensive project report has been submitted in partial fulfillment of the requirements for the degree of*

## **Bachelor of Technology** *in* **ELECTRONICS & COMMUNICATION ENGINEERING**

*Under the supervision of*

**Mr. Arpan Deyasi**

Assistant Professor



**Department of Electronics & Communication Engineering**  
**RCC INSTITUTE OF INFORMATION TECHNOLOGY**  
**Affiliated to Maulana Abul Kalam Azad University of Technology, WestBengal**  
**CANAL SOUTH ROAD, BELIAGHATA, KOLKATA - 700015**

**May, 2018**

## **CERTIFICATE OF APPROVAL**



This is to certify that the project titled **VEHICLE MOVEMENT STREET LIGHT WITH  
AUTOMATIC LIGHT SENSING** carried out by

Name	Roll No.	Registration No:
<b>ANIKESH KUNDU</b>	<b>11700314013</b>	<b>141170110195</b> of 2014-2015
<b>RAUNAK KR SINGH</b>	<b>11700314067</b>	<b>141170110249</b> of 2014-2015
<b>CHANDAN KUMAR RAM</b>	<b>11700314032</b>	<b>141170110214</b> of 2014-2015
<b>SUSITA SAHA</b>	<b>11700314115</b>	<b>141170110297</b> of 2014-2015

for the partial fulfillment of the requirements for B.Tech degree in **Electronics and Communication Engineering** from **Maulana Abul Kalam Azad University of Technology, West Bengal** is absolutely based on his own work under the supervision of Mr. **Arpan Deyasi**. The contents of this thesis, in full or in parts, have not been submitted to any other Institute or University for the award of any degree or diploma.

# DECLARATION



“We Do hereby declare that this submission is our own work conformed to the norms and guidelines given in the Ethical Code of Conduct of the Institute and that, to the best of our knowledge and belief, it contains no material previously written by another neither person nor material (data, theoretical analysis, figures, and text) which has been accepted for the award of any other degree or diploma of the university or other institute of higher learning, except where due acknowledgement has been made in the text.”

.....  
**ANIKESH KUNDU**

Registration No: 141170110195 OF 2014-15  
Roll No: 11700314013

.....  
**RAUNAK KR. SINGH**

Registration No: 141170110249 OF 2014-15  
Roll No: 11700314067

.....  
**CHANDAN KUMAR RAM**

Registration No: 141170110214 OF 2014-15  
Roll No: 11700314032

.....  
**SUSITA SAHA**

Registration No: 141170110297 OF 2014-15  
Roll No: 11700314115

Date:

Place:

## CERTIFICATE of ACCEPTANCE



This is to certify that the project titled **VEHICLE MOVEMENT STREET LIGHT WITH AUTOMATIC LIGHT SENSING** carried out by

Name	Roll No.	Registration No:
<b>ANIKESH KUNDU</b>	<b>11700314013</b>	<b>141170110195</b> of 2014-2015
<b>RAUNAK KR SINGH</b>	<b>11700314067</b>	<b>141170110249</b> of 2014-2015
<b>CHANDAN KUMAR RAM</b>	<b>11700314032</b>	<b>141170110214</b> of 2014-2015
<b>SUSITA SAHA</b>	<b>11700314115</b>	<b>141170110297</b> of 2014-2015

is hereby recommended to be accepted for the partial fulfillment of the requirements for B.Tech degree in **Electronics and Communication Engineering** from **Maulana Abul Kalam Azad University of Technology, West Bengal**

**Name of the Examiner Signature with Date**

1. ....

2. ....

3. ....

4. ....

# ABSTRACT

Smart Street light is an automated system which automates the street. The main aim of Smart Street light is to reduce the power consumption when there are no vehicle movements on the road. The Smart street light will glow with high intensity when there are vehicles on the road otherwise the lights will remain dim. With advancement of technology, things are becoming simpler and easier for everyone in the world today. Automation is the use of control systems and information technologies to reduce the need for human work in the production of goods and services. In the scope of industrialization, automation is a step beyond mechanization, whereas mechanization provided human operators with machinery to assist the users with the muscular requirements of work, automation greatly decreases the need for human sensory and mental requirements as well. Automation plays an increasingly important role in the world economy and in daily experience. Automatic systems are being preferred over manual system. The research work shows automatic control of streetlights as a result of which power is saved to an extent. The Smart street light provides a solution for energy saving which is achieved by sensing an approaching vehicle using the IR sensors and then switching ON a block of street lights ahead of the vehicle with high intensity. As the vehicle passes by, the trailing lights turn dim automatically. Thus, we save a lot of energy. So when there are no vehicles on the highway, then all the lights will remain dim.

# CONTENTS

TITLE PAGE.....	1
CERTIFICATE .....	Error! Bookmark not defined.2
DECLARATION.....	Error! Bookmark not defined.3
CERTIFICATE of ACCEPTANCE.....	4
ABSTRACT .....	5
CONTENTS .....	Error! Bookmark not defined.
LIST OF FIGURES .....	7
Introduction .....	Error! Bookmark not defined.
Theory.....	10-18
2.1 Smart Street Lighting .....	Error! Bookmark not defined.
2.2 Arduino Uno R3 .....	Error! Bookmark not defined.
2.3 IR sensor .....	13-14
2.4 Light Dependant Resistor Circuit .....	15-16Error! Bookmark not defined.
2.5 Light Emitting Diode.....	17-18
Working Procedure.....	19-20
Results and Discussion.....	21-26
Coding.....	27-32
Application and Advantages.....	33
Limitations and Future Work.....	34
Conclusion.....	35
ACKNOWLEDGEMENT.....	36
REFERENCE.....	37

# LIST OF FIGURES

Fig 2.1	Arduino Board	
Fig 2.2	Circuit Diagram of IR Sensor	
Fig 2.3	IR Sensor	
Fig 2.4	LDR Circuit	
Fig 2.5	Light Dependant Resistor	
Fig 2.6	LED Structure	
Fig 2.7	LED	
Fig 3.1	Circuit Diagram of Smart Street Light using IR Sensors	
Fig 4.1	Initial Setup Phase 1	
Fig 4.2	Initial Setup Phase 2	
Fig 4.3	Operation Phase 1	
Fig 4.4	Operation Phase 2	
Fig 4.5	Operation Phase 3	
Fig 4.6	Operation Phase 4	

## Chapter 1

# Introduction

Automation plays an increasingly very important role in the world economy and in daily life. Automatic systems are being preferred over any kind of manual system. We can also call it an “SMART STREET LIGHT SENSING”. Intelligent light sensing refers to public street lighting that adapts to movement by pedestrians, cyclists and cars. Intelligent street lighting, also referred to as adaptive street lighting, dims when no activity is detected, but brightens when movement is detected. This type of lighting is different from traditional, stationary and illumination, or dimmable street lighting that dims at pre-determined times.

The research work shows automatic control of streetlights as a result of which power is saved to some extent. In the scope of industrialization, automation is a step beyond mechanization. Whereas mechanization provided human operators with machinery to assist the users with muscular requirements of work, automation greatly decreases the need for human sensory and mental requirements as well. Basically, street lighting is one of the important parts. Therefore, the street lamps are relatively simple but with the development of urbanization, the number of streets increases rapidly with high traffic density. There are several factors need to be considered in order to design a good street lighting system such as night-time safety for community members and road users, provide public lighting at cost effective, the reduction of crime and minimizing it is effect on the environment. At the beginning, street lamps were controlled by manual control where a control switch is set in each of the street lamps which is called the first generation of the original street light. After that, another method that has been used was optical control method done using high pressure sodium lamp in their system. Nowadays, it is seen that the method is widely used in the country. The method operates by set up an optical control circuit, change the resistance by using of light sensitive device to control street lamps light up automatically at



dusk and turn off automatically after dawn in the morning. Due to the technological development nowadays, road lighting can be categorized according to the installation area and performance, for an example, lighting for traffic routes, lighting for subsidiary roads and lighting for urban center and public amenity areas. The WSN helps in improving the network sensing for street lighting. Meanwhile, street light system can be classified according to the type of lamps used such as incandescent light, mercury vapor light, metal halide light, high pressure sodium light, low pressure sodium light, fluorescent light, compact fluorescent light, induction light and LED light. Different type of light technology used in lighting design with their luminous efficiency, lamp service life and their considerations. The LED is considered a promising solution to modern street lighting system due to its behavior and advantages. Apart from that, the advantages of LED are likely to replace the traditional street lamps such as the incandescent lamp, fluorescent lamp and high-pressure Sodium Lamp in future but LED technology is an extremely difficult process that requires a combination of advanced production lines, top quality materials and high-precision manufacturing process. Therefore, the research work highlights the energy efficient system of the street lights system using LED lamps with IR sensor interface for controlling and managing.

## Chapter 2

# Theory

### 2.1 Smart Street Lighting

Street lights are doing more than ever in today's smart cities. With digital networks and embedded sensors, they collect and transmit information that help cities monitor and respond to any circumstance, from traffic and air quality to crowds and noise. They can detect traffic congestion and track available parking spaces. Those very same networks can remotely control LED lights to turn on and off, flash, dim and more, offering cities a chance to maximize low-energy lighting benefits while also improving pedestrian and bicyclist safety. With street lights creating a network canopy, those networks of data can be used by more than just lighting departments, empowering even schools and businesses via a lighting infrastructure that brightens the future of the digital city.

Smart lighting helps cities save energy, lower costs, reduce maintenance—all while better serving citizens and reducing energy use and CO2 emissions. Automation and networked control can further increase your energy savings and reduce maintenance spending. Networked street lighting built on a scalable platform can reduce crime up to 10% and make roadways safer through improved visibility. Leveraging intelligent control systems can rapidly increase lighting efficiencies and traffic management.

## 2.2 Arduino Uno R3

It is a microcontroller board based on the ATmega328. Arduino is an open-source, prototyping platform and its simplicity makes it ideal for hobbyists or novice to use as well as professionals. The Arduino Uno has 14 digital input/output pins (of which 6 can be used as PWM outputs), 6 analog inputs, a 16 MHz crystal oscillator, a USB connection, a power jack, an ICSP header, and a reset button. It contains everything needed to support the microcontroller; simply connect it to a computer with a USB cable or power it with AC-to-DC adapter or battery to get started.

The Arduino Uno R3 uses an ATmega16U2 instead of the 8U2 found on the Uno (or the FTDI found on previous generations). This allows for faster transfer rates and more memory. No drivers needed for Linux or Mac (in file for Windows is needed and included in the Arduino IDE), and the ability to have the Uno show up as a keyboard, mouse, joystick, etc. The Arduino Uno differs from all preceding boards in that it does not use the FTDI USB-to-serial driver chip. Instead, it features the Atmega8U2 microcontroller chip programmed as a USB-to-serial converter.

The Uno R3 also adds SDA and SCL pins next to the AREF. In addition, there are two new pins placed near the RESET pin. One is the IOREF that allow the shields to adapt to the voltage provided from the board. The other is a not connected and is reserved for future purposes. The Uno R3 works with all existing shields but can adapt to new shields which use these additional pins.

"Uno" means one in Italian and is named to mark the upcoming release of Arduino 1.0. Preferred quality and originals are made in Italy. The Arduino Uno and version 1.0 will be the reference versions of Arduino, moving forward. The Uno is the latest in a series of USB Arduino boards, and the reference model for the Arduino platform.



Fig. 2.1 Arduino Board

### Features of the Arduino UNO:

- Microcontroller: ATmega328
- Operating Voltage: 5V
- Input Voltage (recommended): 7-12V
- Input Voltage (limits): 6-18V
- Digital I/O Pins: 14 (of which 6 provide PWM output)
- Analog Input Pins: 6
- DC Current per I/O Pin: 40 mA
- DC Current for 3.3V Pin: 50 mA
- Flash Memory: 32 KB of which 0.5 KB used by bootloader
- SRAM: 2 KB (ATmega328)
- EEPROM: 1 KB (ATmega328)
- Clock Speed: 16 MHz

## **2.3 IR sensor**

An infrared sensor is an electronic device that emits in order to sense some aspects of the surroundings. An IR sensor can measure the heat of an object as well as detects the motion as well as the presence of an object due to intervention or interruption. These type of sensors measure only infrared radiation, rather than emitting it that is called as a **passive IR sensor**. Usually in the infrared spectrum, all the objects radiate some form of thermal radiations. These types of radiations are invisible to our eyes that can be detected by an infrared sensor. The emitter is simply an IR LED (Light Emitting Diode) and the detector is simply an IR photodiode which is sensitive to IR light of the same wavelength as that emitted by the IR LED. When IR light falls on the photodiode, the resistances and these output voltages, change in proportion to the magnitude of the IR light received.

An IR sensor is a device which detects IR radiation falling on it. There are numerous types of IR sensors that are built and can be built depending on the application. Proximity sensors (Used in Touch Screen phones and Edge Avoiding Robots), contrast sensors (Used in Line Following Robots) and obstruction counters/sensors (Used for counting goods and in Burglar Alarms) are some examples, which use IR sensors.

### **Working Mechanism**

An IR sensor is basically a device which consists of a pair of an IR LED and a photodiode which are collectively called a photo-coupler or an opto-coupler. The IR LED emits IR radiation, reception and/or intensity of reception of which by the photodiode dictates the output of the sensor. Now, there are so many ways by which the radiation may or may not be able to reach the photodiode.

#### **Direct incidence**

We may hold the IR LED directly in front of the photodiode, such that almost all the radiation emitted, reaches the photodiode. This creates an invisible line of IR radiation between the IR LED and the photodiode. Now, if an opaque object is placed obstructing this line, the radiation will not reach the photodiode and will get either reflected or absorbed by the obstructing object. This mechanism is used in object counters and burglar alarms.

## Indirect Incidence

High school physics taught us that black color absorbs all radiation, and the color white reflects all radiation. We use this very knowledge to build our IR sensor. If we place the IR LED and the photodiode side by side, close together, the radiation from the IR LED will get emitted straight in the direction to which the IR LED is pointing towards, and so is the photodiode, and hence there will be no incidence of the radiation on the photodiode. Please refer to the right part of the illustration given below for better understanding. But, if we place an opaque object in front of the two, two cases occur:

### Reflective Surface

If the object is reflective, (White or some other light color), then most of the radiation will get reflected by it, and will get incident on the photodiode. For further understanding, please refer to the left part of the illustration below.

### Non-reflective Surface

If the object is non-reflective, (Black or some other dark color), then most of the radiation will get absorbed by it, and will not become incident on the photodiode. It is similar to there being no surface (object) at all, for the sensor, as in both the cases, it does not receive any radiation.

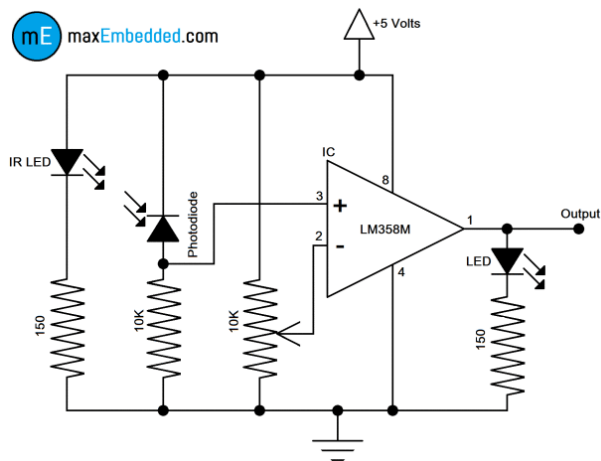

Fig. 2.2 Circuit Diagram of IR Sensor



Fig. 2.3 IR Sensor

## 2.4 Light Dependant Resistor Circuit

LDRs or Light Dependent Resistors are very useful especially in light/dark sensor circuits. Normally the resistance of an LDR is very high, sometimes as high as 1000000 ohms, but when they are illuminated with light resistance drops dramatically. Electronic sensors are the devices that alter their electrical characteristics, in the presences of visible or invisible light. The best-known devices of this type are the light dependent resistor (LDR), the photo diode and the phototransistors. Light dependent resistor as the name suggests depends on light for the variation of resistance. LDR are made by depositing a film of cadmium sulphide or cadmium selenide on a substrate of ceramic containing no or very few free electrons when not illuminated .The longer the strip the more the value of resistance. When light falls on the strip, the resistance decreases. In the absence of light the resistance can be in the order of 10K ohm to 15K ohm and is called the dark resistance. Depending on the exposure of light the resistance can fall down to value of 500 ohms. The power ratings are usually smaller and are in the range 50mw to .5w. Though very sensitive to light, the switching time is very high and hence cannot be used for high frequency applications. They are used in chopper amplifiers. Light dependent resistors are available as discs 0.5cm to 2.5cm. The resistance rises to several Mega ohms under dark conditions. The device consists of a pair of metal film contacts separated by a snakelike track of cadmium sulphide film, designed to provide the maximum possible contact area with the two metal films. The structure is housed in a clear plastic or resin case, to provide free access to external light. Practical LDRs are available in variety of sizes and packages styles, the most popular size having a face diameter of roughly 10mm.

When an LDR is brought from a certain illuminating level into total darkness, the resistance does not increase immediately to the dark value. The recovery rate is specified in k ohm/second and for current LDR types it is more than 200k ohm/second. The recovery rate is much greater in the reverse direction, e.g. going from darkness to illumination level of 300 lux, it takes less than 10ms to reach a resistance which corresponds with a light level of 400 lux. A LDR may be connected either way round and no special precautions are required during the time of soldering.

**Darkness:** Maximum resistance, about 1Mega ohm.

**Very bright light:** Minimum resistance, about 100 ohm. The LDR is a variable resistor whose resistance decreases with the increase in light intensity. Two cadmium photoconductive cells with spectral response are very similar to that of the human eye. The cell resistance falls with increasing light intensity. Some of its features: 1) High reliability. 2) Light weight. 3) Wide spectral response. 4) Wide ambient temperature range.

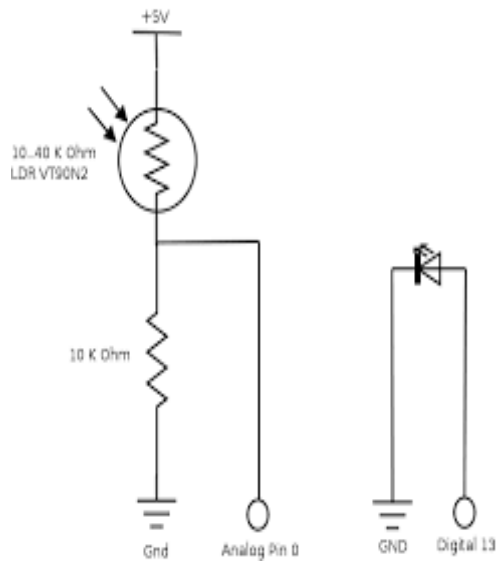

Fig. 2.4 LDR Circuit



Fig. 2.5 Light Dependant Resistor



## 2.5 Light Emitting Diode

A light-emitting diode (LED) is a two-lead semiconductor light source. It is p-n junction diode that emits light when activated. The long terminal is positive and the short terminal is negative. When a suitable current is applied to the leads, electrons are able to recombine with electron holes within the device, releasing energy in the form of photons. This effect is called electroluminescence, and the color of the light (corresponding to the energy of the photon) is determined by the energy band gap of the semiconductor. LEDs are typically small (less than 1 mm<sup>2</sup>) and integrated optical components may be used to shape the radiation pattern.

LEDs are versatile semiconductor with a number of attributes which make them perfect for most applications. Their features include:

- Long Life: LEDs can last over 100,000 hours (10+ years) if used at rated current
- No annoying flicker as we experience with fluorescent lamps.
- LEDs are impervious to heat, cold, shock and vibration.
- LEDs do not contain breakable glass.
- Solid-State, high shock and vibration resistant
- Extremely fast turn on/off times
- Low power consumption puts less load on the electrical systems increasing battery life.

Here we have used the most common 5mm white light. White LEDs are perfect for replacing inefficient incandescent bulbs in night lights and path lights.

SPECIFICATION:

Intensity: 28,500mcd	Voltage: 3.0v-3.3v
Color Freq: x=31 y=32	Typical: 3.1v
Viewing Angle: 48°	Current: 20mA
Lens: Water Clear	

**CAUTIONS:**

LEDs produce a focused light source and extra care should be used for your eyes ,though intensity is not very high. While testing the LEDs a resistance must be applied to it. Also, being a semiconductor device, they are sensitive to static charges.

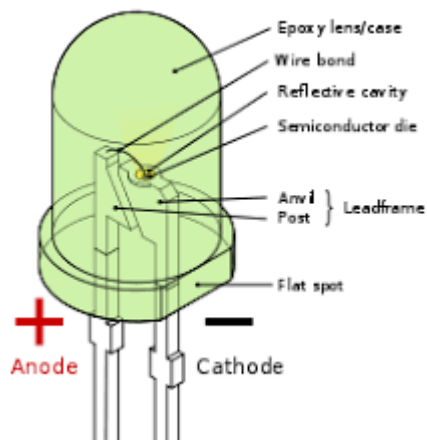

Fig. 2.6 LED Structure



Fig. 2.7 LED

## Chapter 3

# Working Procedure

The working procedure of the Smart street light using IR sensors is explained below. The following are the different steps included in building a Smart street light.

1. Output of the LDR pin is connected to A0 (analog) port of Arduino Uno board.
2. Connect all output of the IR sensors to port numbers A1, A2, A3, A4 and A5 respectively (analog) which is the input signal to the Arduino board.
3. Connect the ground of all the IR sensors to GND port.
4. The output signals from LED are connected to port number 5, 6, 9, 10 and 11 respectively.
5. Again connect all the negative terminals of LED's to GND port.
6. Power is passed to the Arduino (7-12V)

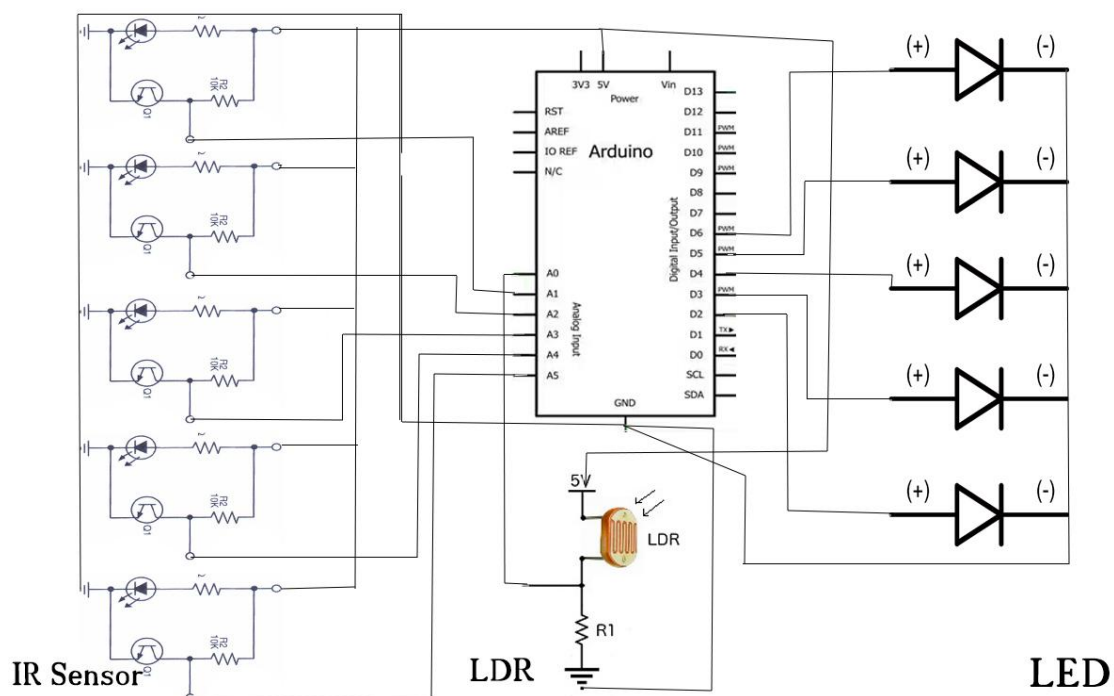

Fig. 3.1 Circuit diagram for Smart street light using IR sensors

The Fig 3.1 is the circuit diagram of the Smart streetlight. It works in accordance with the varying sunlight. Whenever there is sufficient sunlight in surroundings, LDR exhibits high resistance and acts as an insulator, while in darkness this LDR behaves as low resistance path and allows the flows of electricity, this LDR's operates with the help of IR sensors, these sensors are activated under low illumination conditions and these are controlled by an AT89C51 micro controller, every basic electronic circuit will operate under regulated 5v DC. When any object comes in the range of IR sensors, as IR LED emits the radiations and reflected back to IR photodiode by the object. Hence, object is detected.

The heart of Arduino circuit is the low power, high performance Arduino micro controller is programmed by embedded assembly programming language for implementing these tasks; this program is stored and operated by means of storage device EPROM.

The intensity of LED's is remained at low initially (when no object is detected, at no natural light condition) by Arduino using Pulse Width Modulation (PWM) technique where analog signal is converted to digital signal, ON-OFF process of LEDs take place so rapidly in such a way, the LEDs seem to glow dimly when seen by naked eye. Hence, intensity of LEDs are controlled by varying duty cycle.

While coming to the functional block i.e. LDR, LEDs, IR sensors, these components are in expensive, smaller in size, less complexity, highly reliable, low power applications, minimum risk with greater accuracy. The project is successfully implemented in many areas based on the experimental verification proving that it can save the electrical power to greater extent removing the manual work completely; the system became the origin for upcoming advanced intelligent systems in saving both human and electrical power.

The switching of the LEDs are operated through coding applied in Arduino using Aduino software.

## Chapter 4

# Results and Discussion

In this section, the setup of the whole research work is depicted in a step by step manner. Sample screenshots are displayed once the components are fixed and connected to each other. All the components are connected to each other and thus completes the system setup which helps one to understand the steps in a simple and easy way. With these steps, even when a person who is trying to implement the same, it makes it simple, clear and easy. The following are the screenshots in an orderly way:

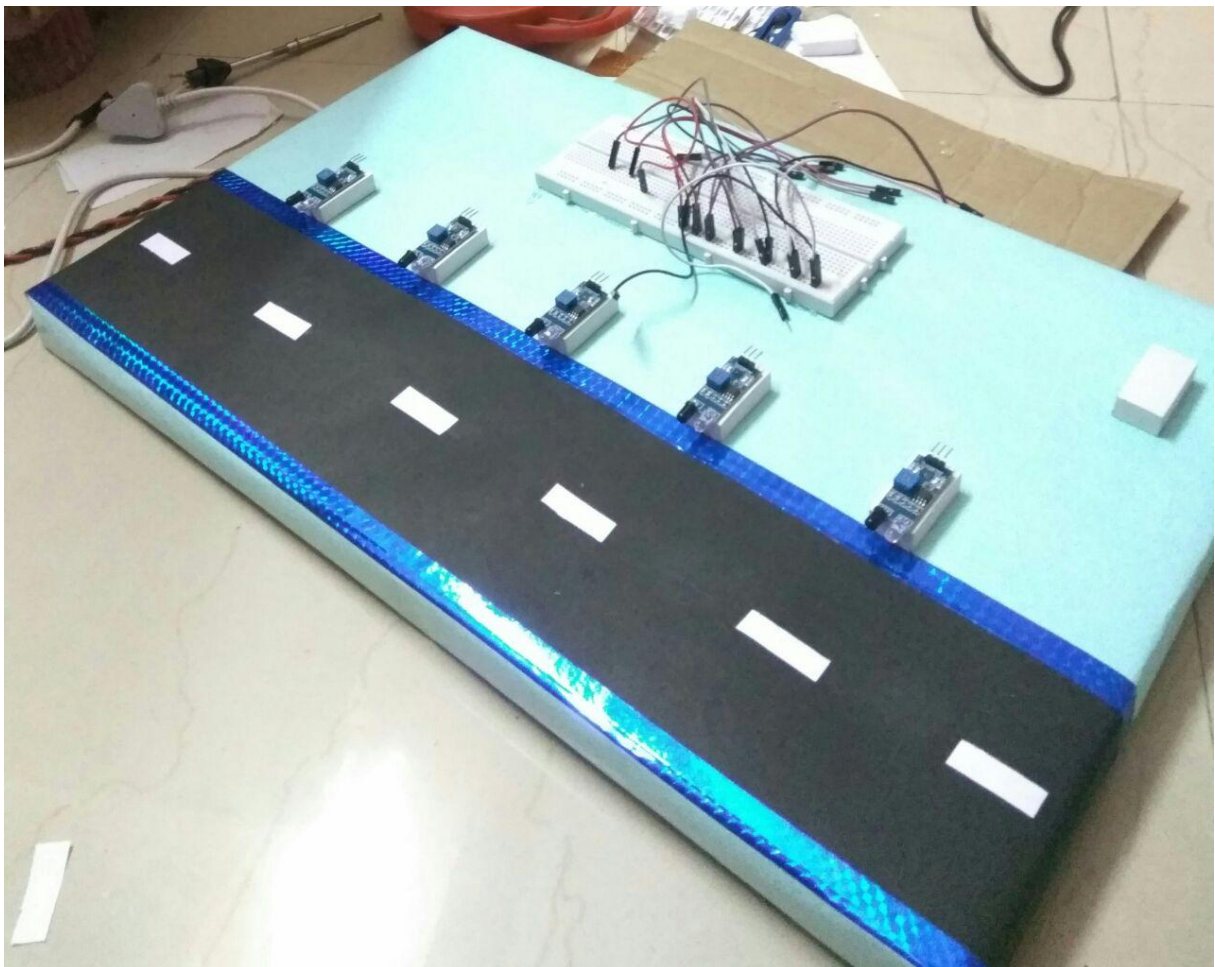

Fig. 4.1 Initial Setup Phase 1

The Fig 4.1 depicts the initial setup of the hardware. All the components are in accordance to every other component. The five IR sensors are placed next to each other. The Arduino board is about to be mounted and connected to the external power supply for the flow of current. All the five IR sensors are going to be connected to the Arduino board. All the wirings with the breadboard are installed.

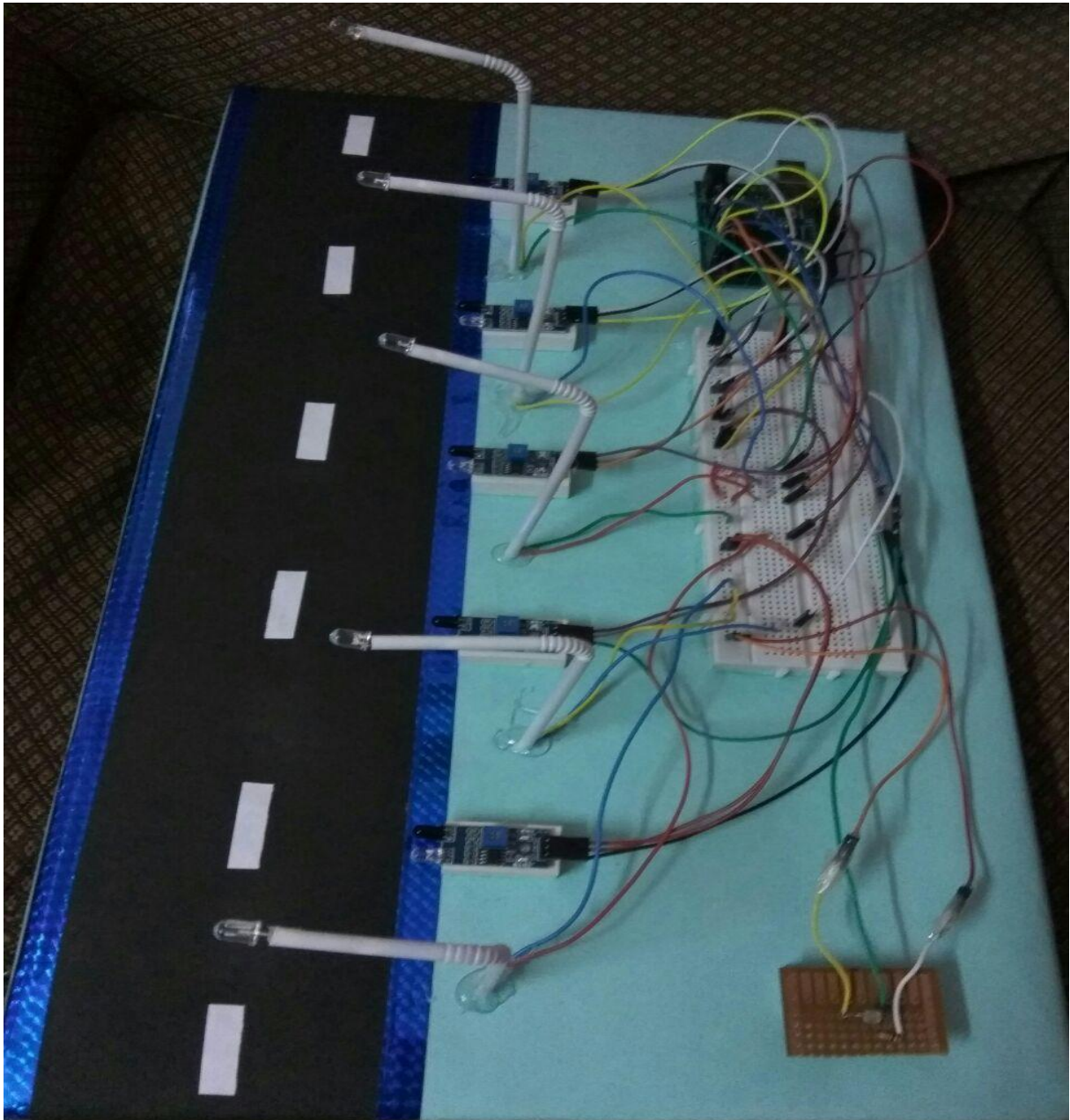

Fig. 4.2 Initial Setup Phase 2

The Fig 4.2 depicts the second phase where all the LEDs are connected with the Arduino

and Arduino is mounted. All the connections are completed, as soon as the 5V power supply is fed to the input Arduino, circuit will start to work perfectly.

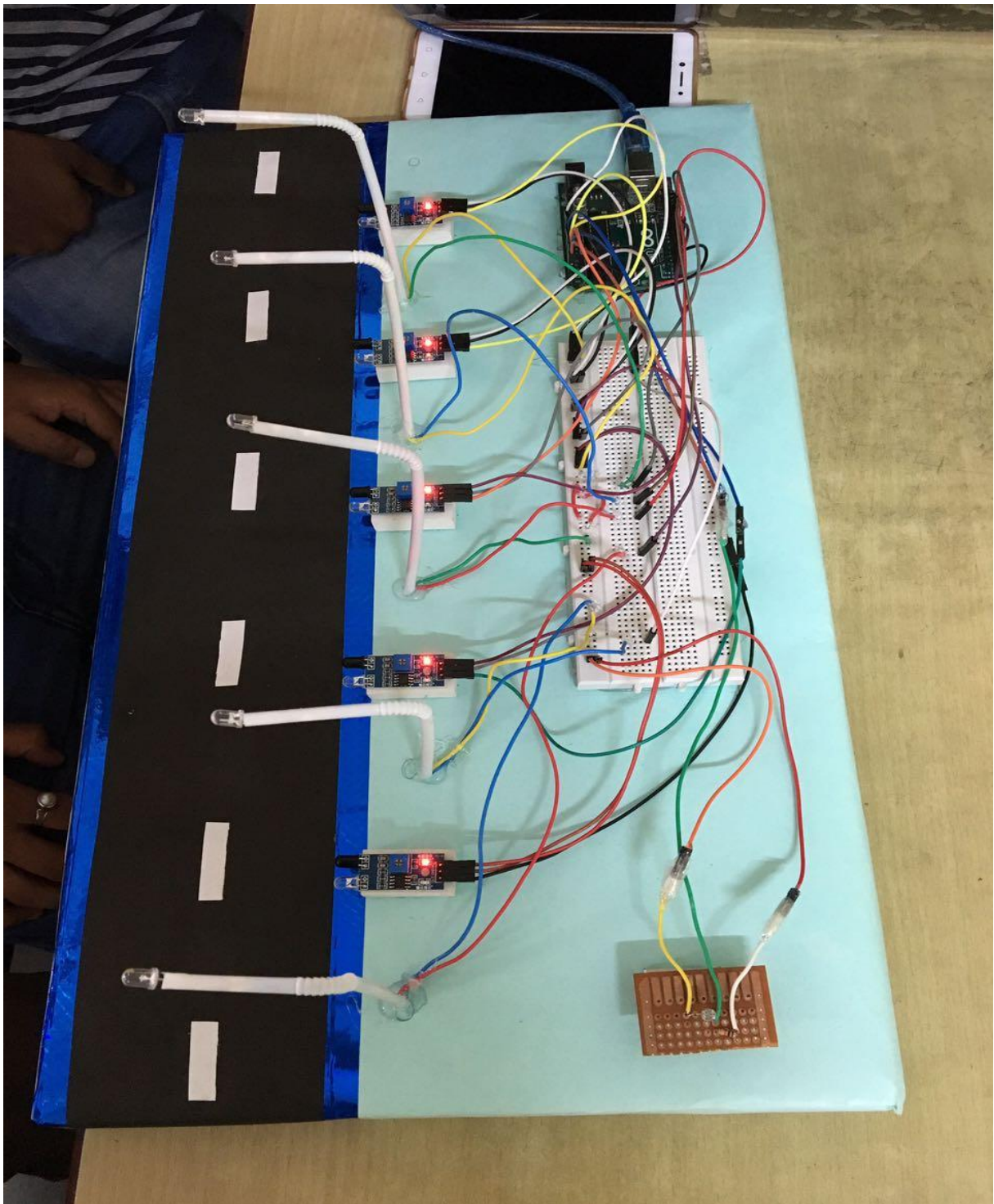

Fig. 4.3 Operation Phase 1

The Fig. 4.3 shows the initial operation when power is supplied to the Arduino at the

natural lighting condition. Thus, LDR circuit detects light and LDR works as an insulator, does not allow the current to pass through the circuit. Hence, LEDs are remained turn off.

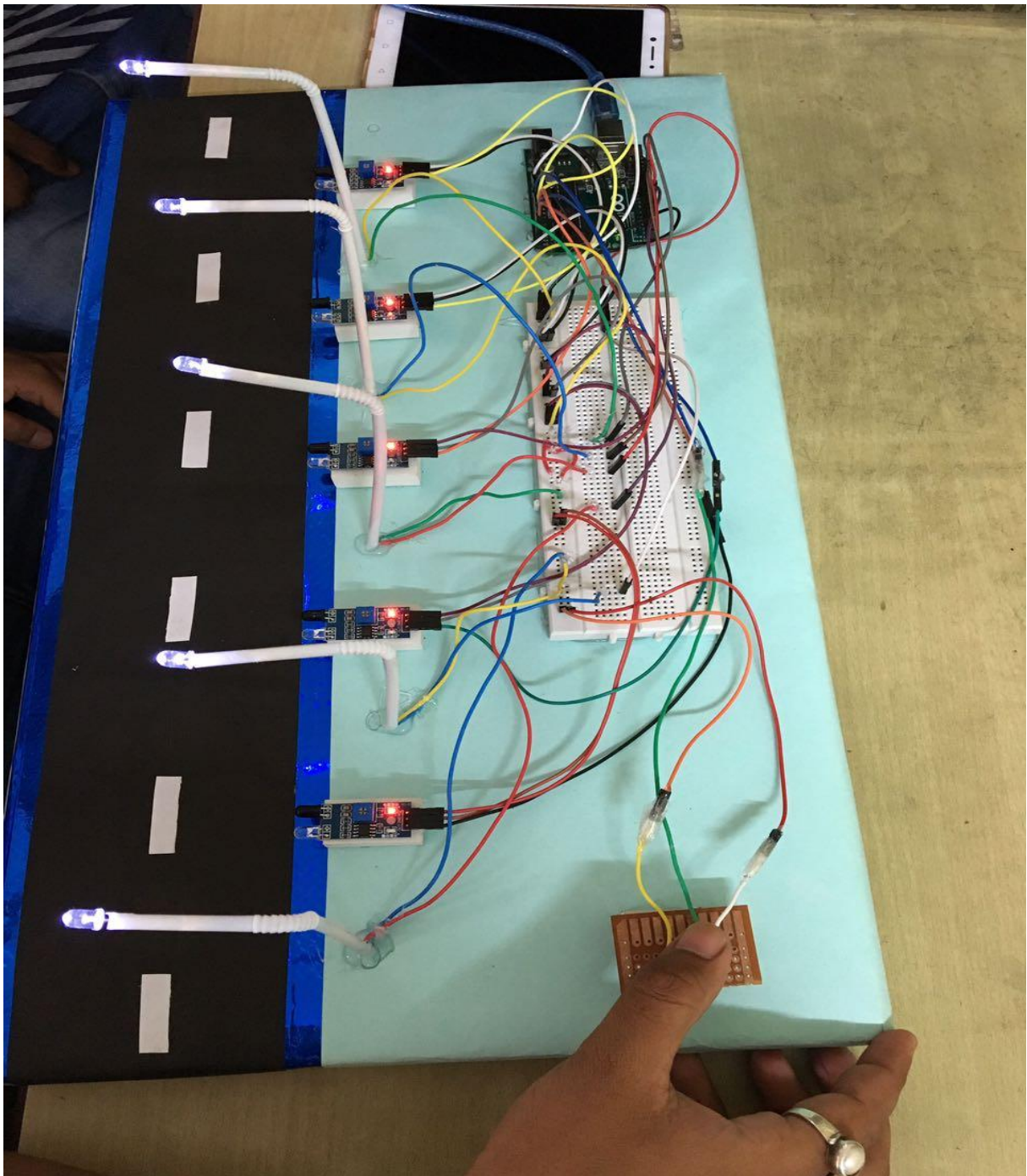

Fig. 4.4 Operation Phase 2

In Fig. 4.4, LDR is hidden by finger tip, to create natural dark condition. Due to no light, the resistance of LDR becomes very low, allowing current to pass through the LDR circuit. Thus, LEDs glow dimly.



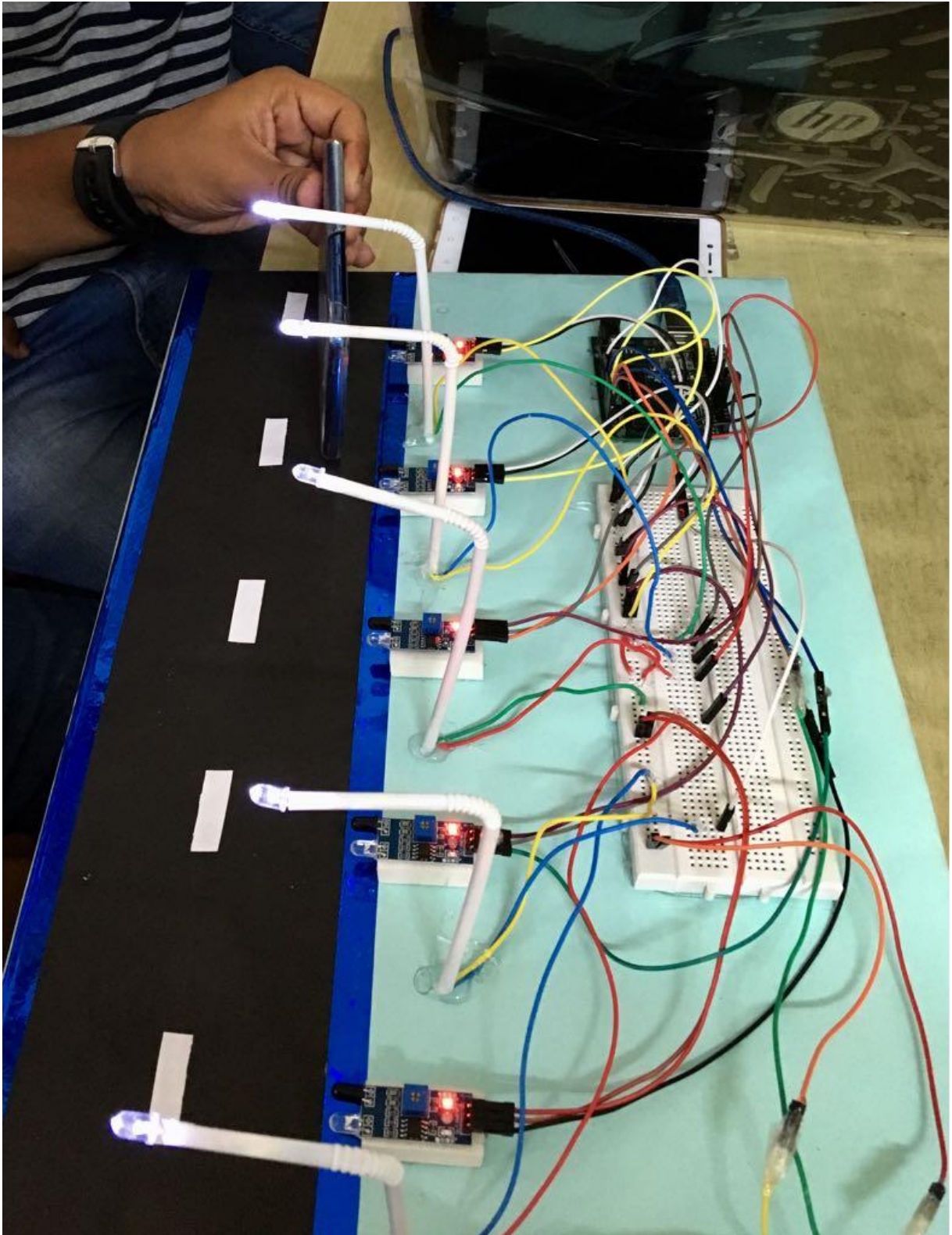

Fig. 4.5 Operation Phase 3

Fig. 4.5 depicts when any object is detected by the first sensor first two adjacent LEDs glow with its full intensity keeping rest of the LEDs lit dimly.

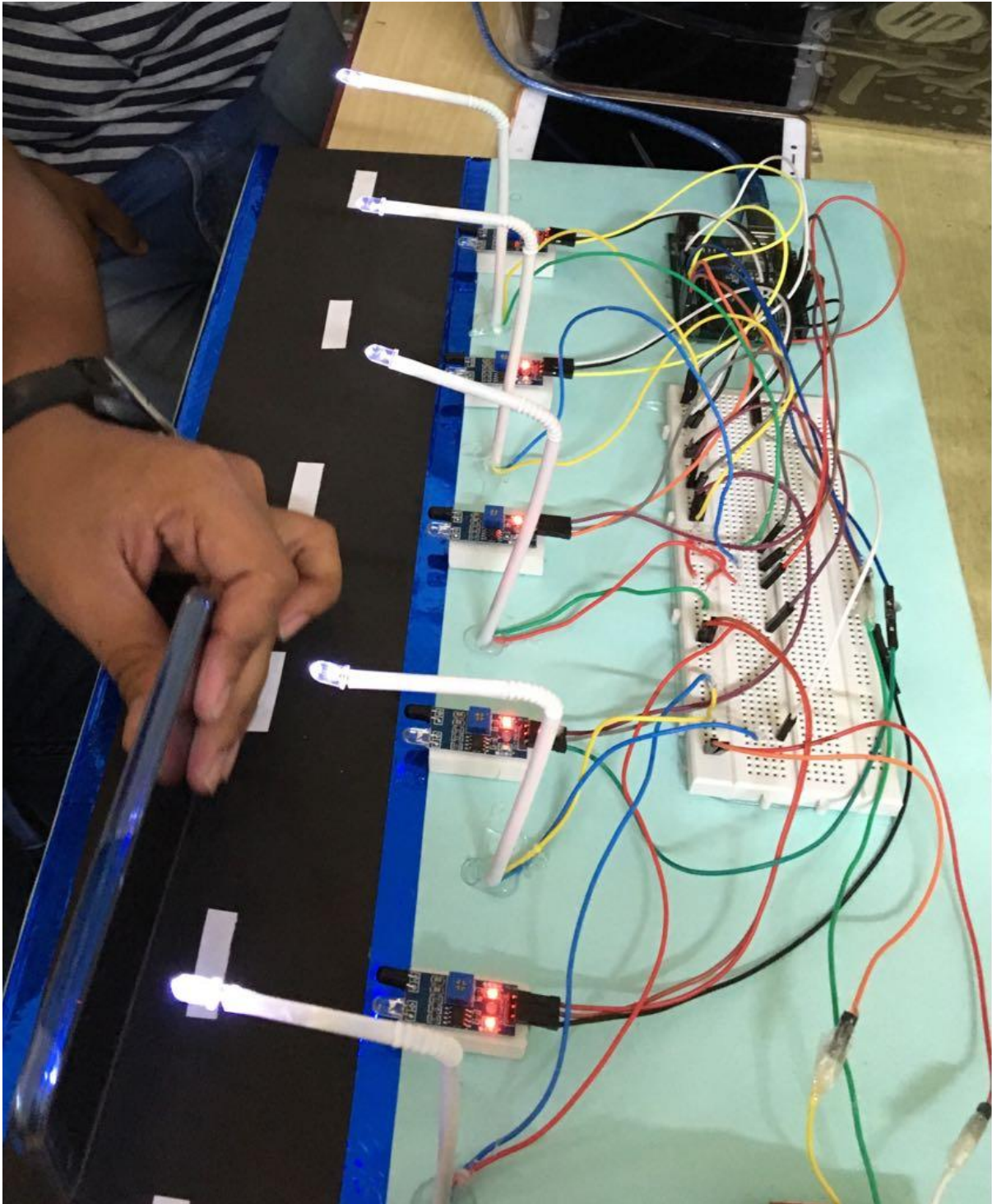

Fig. 4.6 Operation Phase 4

Fig. 4.6 shows that fourth IR sensor detects the object and glows the corresponding LED and the successive LED with full intensity keeping rest of LEDs lit dimly.

## Chapter 5

# Coding

```
int led = 11;

int led1 = 10;

int led2 = 9;

int led3 = 6;

int led4 = 5;

int ldr = A0;

int x1, x2, x3, x4,x5;

void setup()
{
  Serial.begin (9600);

  pinMode (led,OUTPUT);

  pinMode (led1,OUTPUT);

  pinMode (led2,OUTPUT);

  pinMode (led3,OUTPUT);

  pinMode (led4,OUTPUT);

  pinMode (ldr,INPUT);
}

void loop()
{
```

```

int ldrStatus = analogRead (ldr);

if (ldrStatus <=300)

{

    if (analogRead(A1)<500)    // IR 1 CODE

    {

        x1=0;

        x2=1;

        digitalWrite(led,HIGH);

        digitalWrite(led1,HIGH);

        delay(100);// micro second

    }

else

    {

        if(x1==0){

            digitalWrite(led,HIGH);

            analogWrite(led,255/5);

            delay(50);

        }

        if(x2==1){

            digitalWrite(led1,HIGH);

            analogWrite(led1,255/5);

            delay(50);

```

```

    }

}

if (analogRead(A2)<500)    // IR 2 CODE

{

x2=0;

x3=1;

digitalWrite(led1,HIGH);

digitalWrite(led2,HIGH);

delay(100);// micro second

}

else

{

if(x2==0)

{

digitalWrite(led1,HIGH);

analogWrite(led1,255/5);

delay(50);

}

if(x3==1)

{

digitalWrite(led2,HIGH);

analogWrite(led2,255/5);

delay(50);

```

```

    }

}

if (analogRead(A3)<500)    // IR 3 CODE

{

x3=0;

x4=1;

digitalWrite(led2,HIGH);

digitalWrite(led3,HIGH);

    delay(100);// micro second

}

else

{

    if(x3==0)

    {

        digitalWrite(led2,HIGH);

        analogWrite(led2,255/5);

        delay(50);

    }

    if(x4==1)

    {

        digitalWrite(led3,HIGH);

        analogWrite(led3,255/5);

        delay(50);

    }

}

}

```

```

    }

}

if (analogRead(A4)<500)    // IR 4 CODE

{

x4=0;

x5=1;

digitalWrite(led3,HIGH);

digitalWrite(led4,HIGH);

    delay(100);// micro second

}

else

{

    if(x4==0){

        digitalWrite(led3,HIGH);

        analogWrite(led3,255/5);

        delay(50);

    }

    if(x5==1){

        digitalWrite(led4,HIGH);

        analogWrite(led4,255/5);

        delay(50);

    }

}

}

```

```

    if (analogRead(A5)<500)    // IR 5 CODE
    {
        x5=0;

        digitalWrite(led4,HIGH);

        delay(100);// micro second
    }
else
    {
        if(x5==0){

            digitalWrite(led4,HIGH);

            analogWrite(led4,255/5);

            delay(50);

        }

    }
}
else
{
    digitalWrite(led, LOW);

    digitalWrite(led1, LOW);

    digitalWrite(led2, LOW);

    digitalWrite(led3, LOW);

    digitalWrite(led4, LOW);

}
}

```



## Chapter 6

# Application and Advantages

- The street light control circuit can be used in normal roads, highways, express ways etc.
- The project can also be used in parking areas of malls, hotels, industrial lighting, etc.
- If the lighting system implements all LED lights, the cost of the maintenance can be reduced as the life span and durability of LEDs is higher than Neon based lights which are normally used as street lights.
- As the lights are automatically turned ON or OFF, huge amount of energy can be saved.
- This system less costly, less installation and maintenance cost and more efficient as compared to the others system

## Chapter 7

# Limitations and Future Work

- This system can be used for only one way traffic. A highway might be covered by this system on dual system installation on both side.
- The system does not have any automatic fault detector.
- Pole damage detection with the addition of suitable sensor can be implemented.

## Chapter 8

# Conclusion

By using Smart Street light, one can save surplus amount of energy which is done by replacing sodium vapor lamps by LED and adding an additional feature for security purposes. It prevents unnecessary wastage of electricity, caused due to manual switching of streetlights when it's not required. It provides an efficient and smart automatic streetlight control system with the help of IR sensors. It can reduce the energy consumption and maintains the cost. The system is versatile, extendable and totally adjustable to user needs.

- The system is now used only for One way traffic in highways.
- Continuous uses of LDR and IR sensors even in day time.
- Not switched on before the sunset.

The Smart light system can be further extended to make the current system in two-way traffic, making the system more flexible in case of rainy days and introduction of ways to control the lights through GSM based service.

# ACKNOWLEDGEMENT

The experience has enabled us to use many of the theoretical ideas we had acquired into practical use. With a deep sense of credit we sincerely thank our Assistant Professor, *Mr. Arpan Deyasi*, *Dept. of Electronics and Communication*, RCC Institute of Information Technology, Kolkata, West Bengal for facilitating us to work in a flexible manner, giving us all the necessary support throughout the research and project work and supervising us to come up with a meaningful report. Finally, we would like to thank all the staff members of the of Electronics and Communication department, Regional Computer Centre Institute of Information Technology for their inspiration, support and kind cooperation in completing the final year project.

## References

1. International Journal of Innovative Research in Computer and Communication Engineering  
(An ISO 3297: 2007 Certified Organization)  
Website: [www.ijircce.com](http://www.ijircce.com)  
Vol. 5, Issue 3, March 2017  
Smart Street Light Using Arduino Uno Microcontroller
2. S. Suganya, R. Sinduja, T. Sowmiya& S. Senthilkumar, Street light glow on detecting vehicle movement using sensor
3. K.Santha Sheela,S.Padmadevi, Survey on Street Lighting System Based On Vehicle Movements
4. Srikanth M, Sudhakar K N,ZigBee Based Remote Control Automatic Street Light System
5. M.Abhishek, Syed ajram shah, K.Chetan, K,Arun Kumar, Design and implementation of traffic flow based street light control system with effective utilization of solar energy, International journal of Science Engineering and Advance Technology, IJSEAT, Vol 3, Issue