

Design And Enhancement of Gain & Bandwidth Of Rectangular Patch Antenna

by

Name	Roll No.	Registration No:
Saikat Das	11700314076	141170110258 of 2014-2015
<i>Arnab Ghosh</i>	11700314025	141170110207 of 2014-2015
<i>Subham Halder</i>	11700314112	141170110294 of 2014-2015
<i>Rahul Roy</i>	11700314065	141170110247 of 2014-2015

*A comprehensive project report has been submitted in partial fulfillment of
the requirements for the degree of*

Bachelor of Technology

in

ELECTRONICS & COMMUNICATION ENGINEERING

Under the supervision of

Mrs. Pampa Debnath

Assistant / Associate / Professor



Department of Electronics & Communication Engineering
RCC INSTITUTE OF INFORMATION TECHNOLOGY
Affiliated to Maulana Abul Kalam Azad University of Technology, WestBengal
CANAL SOUTH ROAD, BELIAGHATA, KOLKATA – 700015

May, 2018

CERTIFICATE OF APPROVAL



This is to certify that the project titled “Design And Enhancement of Gain & Bandwidth Of Rectangular Patch Antenna” carried out by

Name	Roll No.	Registration No:
Saikat Das	11700314076	141170110258 of 2014-2015
<i>Arnab Ghosh</i>	11700314025	141170110207 of 2014-2015
<i>Subham Halder</i>	11700314112	141170110294 of 2014-2015
<i>Rahul Roy</i>	11700314065	141170110247 of 2014-2015

for the partial fulfillment of the requirements for B.Tech degree in **Electronics and Communication Engineering** from **Maulana Abul Kalam Azad University of Technology, West Bengal** absolutely based on his own work under the supervision of Dr./ Mr./Ms./Mrs. **Mrs. Pampa Debnath**. The contents of this thesis, in full or in parts, have not been submitted to any other Institute or University for the award of any degree or diploma.

Optional in case of External Supervisor

.....
Dr./Mr./Ms./Mrs. XXXXX XXXXX
Designation and Department
Institute

.....
Dr./Mr./Ms./Mrs. XXXXX XXXXX
Professor , Dept. of ECE
RCC Institute of Information Technology

.....
Dr. Abhishek Basu
Head of the Department (ECE)
RCC Institute of Information Technology

DECLARATION



“We Do hereby declare that this submission is our own work conformed to the norms and guidelines given in the Ethical Code of Conduct of the Institute and that, to the best of our knowledge and belief, it contains no material previously written by another neither person nor material (data, theoretical analysis, figures, and text) which has been accepted for the award of any other degree or diploma of the university or other institute of higher learning, except where due acknowledgement has been made in the text.”

.....
Saikat Das
Registration No: 141170110258 of 2014-2015
Roll No: 11700314076

.....
Arnab Ghosh
Registration No: 141170110207 of 2014-2015
Roll No: 11700314025

.....
Subham Halder
Registration No: 141170110294 of 2014-2015
Roll No: 11700314112

.....
Rahul Roy
Registration No: 141170110247 of 2014-2015
Roll No: 11700314065

Date:

Place:

CERTIFICATE of ACCEPTANCE



This is to certify that the project titled “Design And Enhancement of Gain & Bandwidth Of Rectangular Patch Antenna” carried out by

Name	Roll No.	Registration No:
Saikat Das	11700314076	141170110258 of 2014-2015
<i>Arnab Ghosh</i>	11700314025	141170110207 of 2014-2015
<i>Subham Halder</i>	11700314112	141170110294 of 2014-2015
<i>Rahul Roy</i>	11700314065	141170110247 of 2014-2015

is hereby recommended to be accepted for the partial fulfillment of the requirements for B.Tech degree in **Electronics and Communication Engineering** from **Maulana Abul Kalam Azad University of Technology, West Bengal**

Name of the Examiner Signature with Date

1.

2.....

3.....

4.

ABSTRACT

A Microstrip Patch Antenna is a type of radio antenna with a low profile, which can be mounted on a low surface. It is a narrow band, wide-beam fed antenna fabricated by etching the antenna element pattern in metal trace bonded to the dielectric Substrate such as a printed circuit board with a continuous metal layer bonded to the opposite side of the substrate which forms a ground plane. The main aim of this work is to design, develop and test the Microstrip Patch antenna. This study also emphasizes on simulation of micro-strip patch antenna using HFSS software & study the radiation pattern & radiation pattern parameters and comparison with specifications/requirements. Coaxial probe feed technique was adopted. This work is also focused on characterization of fabricated antenna in view of parameters like VSWR, Antenna efficiency, Axial ratio, Gain and radiation pattern.

CONTENTS

CERTIFICATE	1
DECLARATION	2
CERTIFICATE of ACCEPTANCE.....	3
ABSTRACT.....	4
CONTENTS	5
LIST OF SYMBOLS.....	Error! Bookmark not defined.6
LIST OF ABBREVIATIONS	7
LIST OF FIGURES.....	8
LIST OF TABLES	9
Introduction	10
1.1 problem defination	13Error! Bookmark not defined.
1.2 problem statement	14Error! Bookmark not defined.
1.3 analysis	15
1.4 outcome.....	Error! Bookmark not defined.
REFERENCE	

LIST OF SYMBOLS

L	<u>Length</u>
W	<u>Width</u>
H	<u>Height</u>
C	<u>Velocity of light</u>
ϵ_r	<u>Relative permittivity</u>

LIST OF ABBREVIATIONS

<u>mm</u>	<u>millimeter</u>
<u>Ghz</u>	<u>gigahertz</u>

LIST OF FIGURES

Fig1.1	Microstrip Line Feed	11
Fig1.2	Coaxial Probe Feed	11
Fig1.3	Proximity coupled Feed	12
Fig1.4	Aperture coupled feed	13
Fig2.1	Rectangular micro strip patch antenna design	14
Fig2.2	Assign boundaries of Perfect E1	15
Fig2.3	Assign boundaries of Perfect E2	15
Fig2.4	Assign boundaries of radiation	16
Fig2.5	XY Plot 1(dB vs freq Plot)	19
Fig2.6	Radiation Pattern	19
Fig2.7	XY Plot 2(dB vs Theta Plot)	19

Chapter 1

INTRODUCTION TO MICROSTRIP PATCH ANTENNA:

There is an increase in demand for microstrip antennas with improved performance for wireless communication applications are widely used for this purpose because of their planar structure, low profile, light weight, moderate efficiency and ease of integration with active devices.

Almost all the important wireless applications lie in the band starting from 900 MHz to 5.8 GHz. In Modern wireless communication systems, Worldwide Interoperability for Microwave Access (WiMAX) have

been widely applied in mobile devices such as handheld computers and intelligent phones.

Worldwide Interoperability for Microwave Access (WiMAX) technology is most rapidly growing area in the modern wireless communication. This gives users the mobility to move around within a broad coverage area and still be connected to the network. This provides greatly increased freedom and flexibility. For the home user, wireless has become popular due to ease of installation, and

location freedom. So, there is continuously increasing requirements of efficient and high performance antenna. This technique has been widely recognized as a viable, cost-effective and high-speed data connectivity solution, enabling user mobility. In practice, IEEE 802.11 WiMAX standards consist of 3.5-GHz (3.3–3.6 GHz) and 5.5-GHz (5.25–5.85 GHz) frequency bands.

FEEDING TECHNIQUES:

Microstrip patch antennas can be fed by a variety of methods. These methods can be classified into two categories- contacting and non-contacting. In the contacting method, the RF power is fed directly to the radiating patch using a connecting element such as a microstrip line. In the non-contacting scheme, electromagnetic field coupling is done to transfer power between the microstrip line and the radiating patch. The four most popular feed techniques used are the microstrip line, coaxial probe (both contacting schemes), aperture coupling and proximity coupling (both non-contacting schemes).

Microstrip Line Feed:

In this type of feed technique, a conducting strip is connected directly to the edge of the Microstrip patch. The conducting strip is smaller in width as compared to the patch and this kind of feed arrangement has the advantage that the feed can be etched on the same substrate to provide a planar structure. However as the thickness of the dielectric substrate being used, increases, surface waves and spurious feed radiation also increases, which hampers the bandwidth of the antenna. The feed radiation also leads to undesired cross polarized radiation. This method is advantageous due to its simple planar structure.

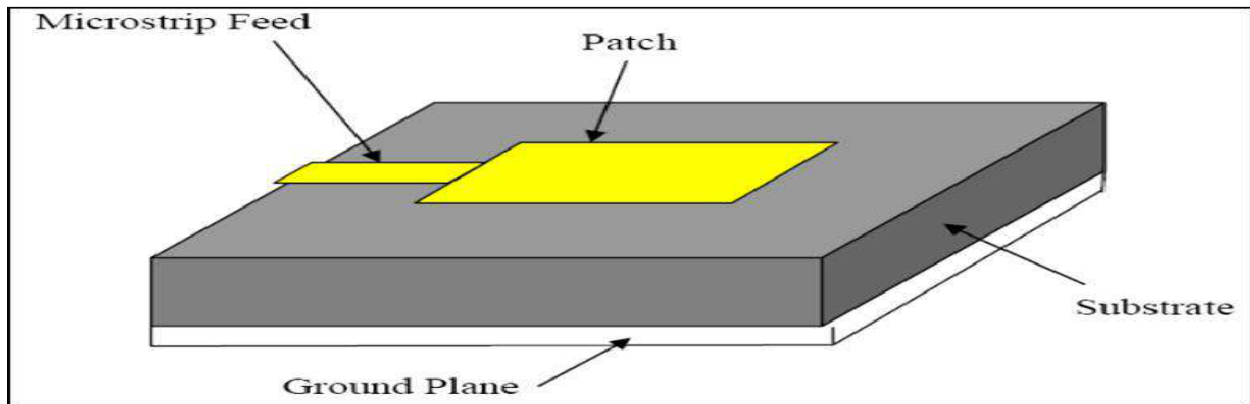

Fig1.1:Microstrip Line Feed

Coaxial Probe Feed:

The Coaxial feed or probe feed is a very common technique used for feeding Microstrip patch antennas. The inner conductor of the coaxial connector extends through the dielectric and is soldered to the radiating patch, while the outer conductor is connected to the ground plane. The main advantage of this type of feeding scheme is that the feed can be placed at any desired location inside the patch in order to match with its input impedance. However, its major drawback is that it provides narrow bandwidth and is difficult to model since a hole has to be drilled in the substrate and the connector protrudes outside the ground plane, thus not making it completely planar for thick substrates. Also, for thicker substrates, the increased probe length makes the input impedance more inductive, leading to matching problems. It is seen above that for a thick dielectric substrate, which provides broad bandwidth, the microstrip line feed and the coaxial feed suffer from numerous disadvantages. So to reduce these types of disadvantages, we will study non-contacting schemes.

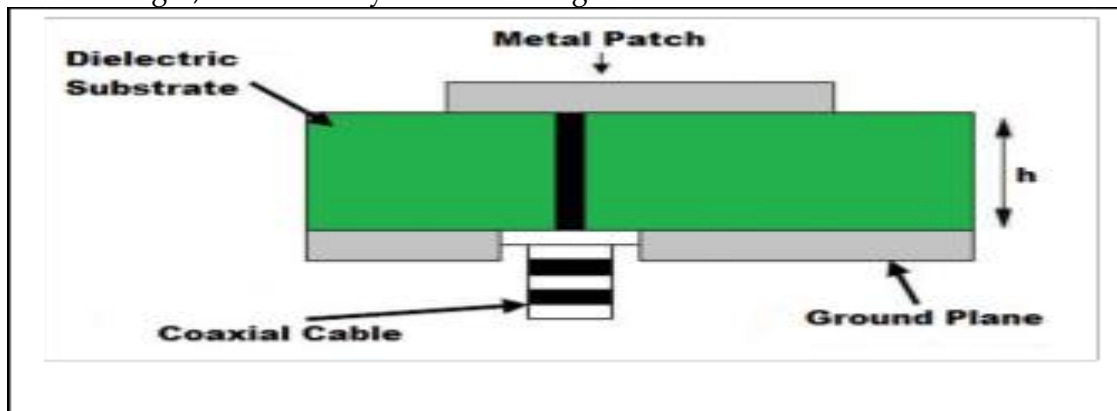

Fig1.2:Coaxial Probe Feed

Proximity coupled Feed:

This type of feed technique is also called as the electromagnetic coupling scheme. Two dielectric substrates are used such that the feed line is between the two substrates and the radiating patch is on top of the upper substrate. The main advantage of this feed technique is that it eliminates spurious feed radiation and provides very high bandwidth (as high as 13%) due to overall increase in the thickness of the microstrip patch antenna. This scheme also provides choices between two different dielectric media, one for the patch and one for the feed line to optimize

the individual performances. This method is advantageous to reduce harmonic radiation of microstrip patch antenna implemented in a multilayer substrate. The goal of the design is the suppression of the resonances at the 2nd and 3rd harmonic frequencies to reduce spurious radiation due to the corresponding patch modes to avoid the radiation of harmonic signals generated by non-linear devices at the amplifying stage. The study shows the possibility of controlling the second harmonic resonance matching by varying the length of the feeding line. On the other hand, the suppression of the third harmonic is achieved by using a compact resonator.

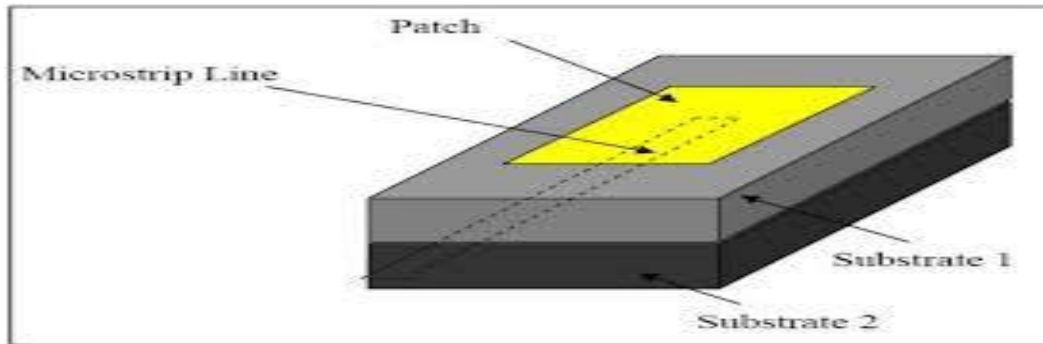

Fig1.3:Proximity coupled Feed

Aperture coupled feed:

In this type of feed technique, the radiating patch and the microstrip feed line are separated by the ground plane. Coupling between the patch and the feed line is made through a slot or an aperture in the ground plane and variations in the coupling will depend upon the size i.e. length and width of the aperture to optimize the result for wider bandwidths and better return losses. The coupling aperture is usually centered under the patch, leading to lower cross-polarization due to symmetry of the configuration. Since the ground plane separates the patch and the feed line, spurious radiation is minimized. Aperture coupled feeding is attractive because of advantages such as no physical contact between the feed and radiator, wider bandwidths, and better isolation between antennas and the feed network. Furthermore, aperture-coupled feeding allows independent optimization of antennas and feed networks by using substrates of different thickness or permittivity

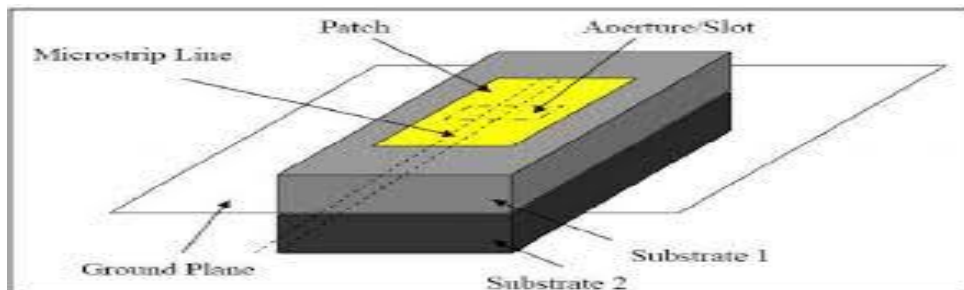

Fig1.4:Aperture coupled feed

Chapter 2

RECTANGULAR MICROSTRIP PATCH ANTENNA DESIGN:

Antennas play a vital role in the field of wireless communications. Some of the antennas are parabolic reflectors, patch antennas, slot antennas, and folded dipole antennas with each type having their own properties and usage. Micro strip antenna technology began its development in the late 1970s. Micro strip patch antenna is one of most important component of communication systems. By definition, an antenna is a device used to transform an RF signal, travel into an electromagnetic wave in free space. The rectangular micro strip antennas play a vital role in wireless communication due to its low-profile, small-size and light weight. A Micro strip Patch antenna consist of a radiating patch on one side of a dielectric substrate which has a ground plane on the other side. The patch is made up of conducting material such as copper or gold. The radiating patch and the feed lines are photo etched on the dielectric substrate.

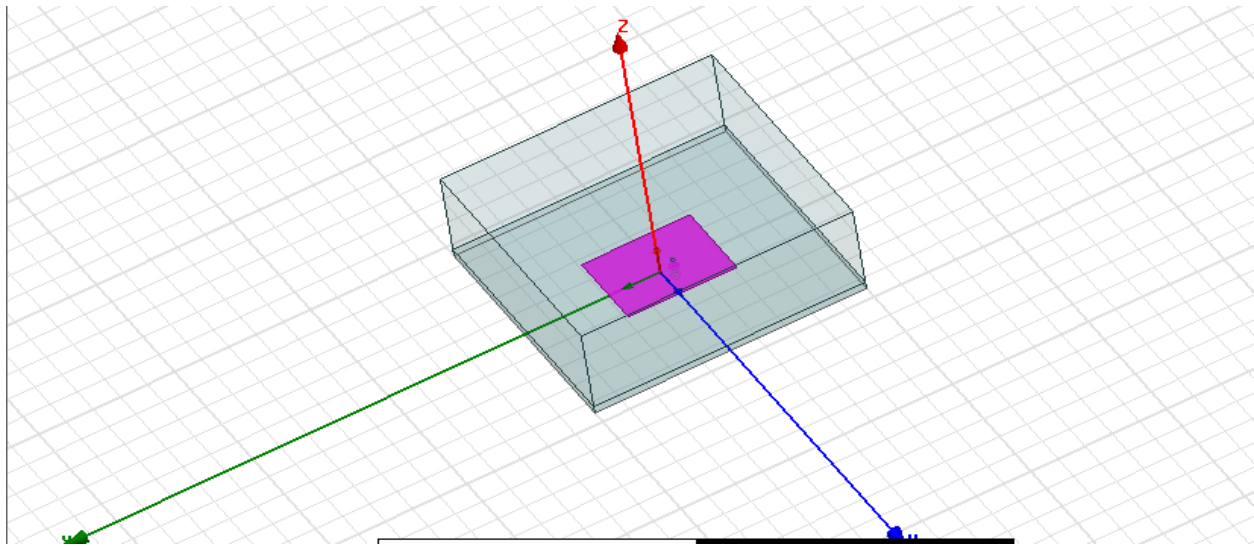

Fig2.1: Rectangular micro strip patch antenna design

DESIGN OF PROPOSED ANTENNA

In this paper Rectangular micro strip patch antenna is designed at 2.4 GHz frequency and simulated. The radiating part (patch) is the dominant figure of a microstrip antenna; the other

components are the ground and substrate, which are on the two sides of the patch.

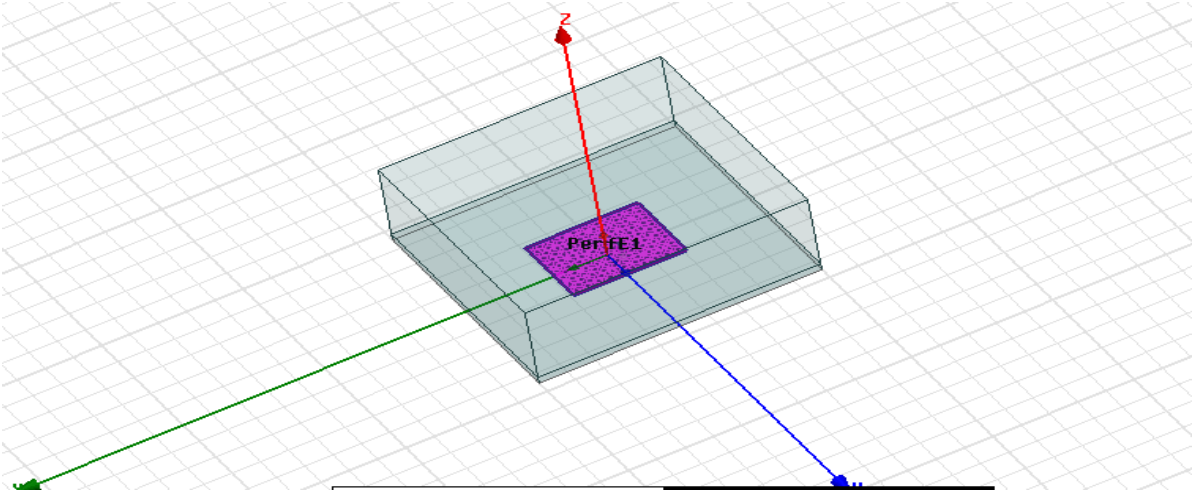

Fig2.2:Assign boundaries of Perfect E1

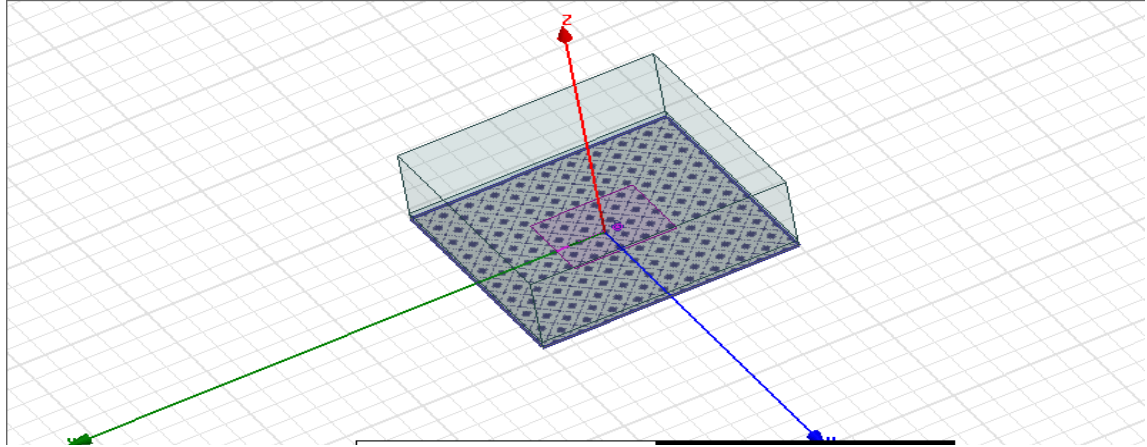

Fig2.3:Assign boundaries of Perfect E2

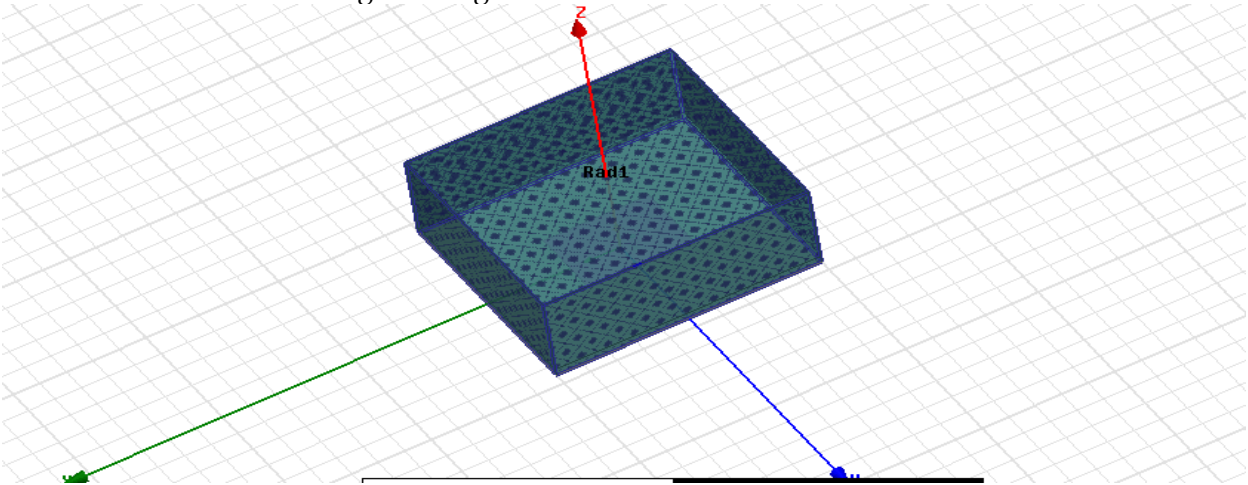

Fig 2.4:Assign boundaries of radiation

The figure 1 represent the microstrip patch antenna design. The figure 2, 3 and 4 indicate the assign boundaries of perf E1, perf E2 and radiation .We have analyses the results using HFSS software. The design consideration is as follows:

Design Considerations:

Substrate material: Rogers RT/duroid 5880

Relative permittivity: 2.2

XSize-100mm

YSize-90mm

Height-3.2mm

The Micro strip patch antenna is designed by using Ansoft HFSS. The cost of Ansoft HFSS is very low and it has the simple procedures to design antenna in a very efficient manner. By simulating this antenna we can get the frequency response, gain, directivity and the radiation pattern. There are many analyzing methods for calculating length, width and height. We use the transmission line analyzing method for the antenna design, which includes mathematical calculations in the antenna design.

Calculation for the Antenna Width (W)

The Width of micro strip patch antenna is given by

$$W = \frac{C}{2f_0 \sqrt{\frac{\epsilon_r + 1}{2}}}$$

Where, C is velocity of light, f_0 is a resonant frequency and ϵ_r is a relative dielectric constant. In this equation we are substituting $C=3 \times 10^{11}$ mm/s, $\epsilon_r = 2.2$ and $f_0=2.4$ GHz, finally by solving this equation we get the width value as 49.42mm.

Calculating the Height of the Antenna(H)

The height (H) of the antenna is given by

$$H = \frac{0.3C}{2\pi f_0 \sqrt{\epsilon_r}}$$

By substituting all the values and solving the equation we get the height of the antenna as 4.02mm for 2.4GHz .

Calculating the Antenna Length (L)

It includes four steps:

Effective Dielectric Constant

Before calculating the length of the antenna we should calculate the several other computations, the first step is to find the effective dielectric constant of the substrate.

The effective dielectric constant value should be closer to the dielectric constant of the substrate.

The effective dielectric constant value is given by

$$\epsilon_{re} = \frac{\epsilon_r + 1}{2} + \frac{\epsilon_r - 1}{2} \left[1 + 12 \frac{h}{w} \right]^{-1/2}$$

By substituting all the values and solving the equation we get the effective dielectric constant value as 2.0266 for 2.4GHz.

Extensive Length

The tangential fields of an antenna are in phase and by combining they will produce the maximum radiation pattern along the two sides of the antenna. The micro strip antenna looks larger in size when compared to its actual size due to its fringing fields so the length of the antenna is extended by its two sides along a path distance of ΔL and it is given by

$$\Delta L = 0.412h \frac{(\epsilon_{re} + 0.3) \left(\frac{w}{h} + 0.264 \right)}{(\epsilon_{re} - 0.258) \left(\frac{w}{h} + 0.8 \right)}$$

By substituting all the values and solving the equation we get the extensive length of the antenna as 2.135mm. for 2.4GHz.

The effective length of the of antenna is given in below and which helps to find the original length of the rectangular micro strip patch antenna and it is written as,

$$L_{eff} = \frac{C}{2f_0\sqrt{\epsilon_{re}}}$$

This is used to calculate the narrow bandwidth of the antenna structure and various parameters of the antenna. By substituting all the values and solving the equation we get the effective length of the antenna as 42.13mm for 2.4GHz.

Actual Length of the Antenna

The actual length of the antenna is calculated by substituting the effective length and the extensive length of the antenna is given by

$$L = L_{eff} - 2\Delta L$$

By substituting all the values and solving the equation we get the length of the antenna as 37.86mm for 2.4GHz.

MICROSTRIP PATCH ANTENNA PARAMETERS:

Parameter	Dimension
Operating/Resonant Frequency (f ₀)	2.4GHz
Dielectric Constant (ε _r)	2.2
Height of substrate(h)	3.2mm
Length(L)	37.86mm
Width(w)	49.42mm

Table 2.1

RESULTS:

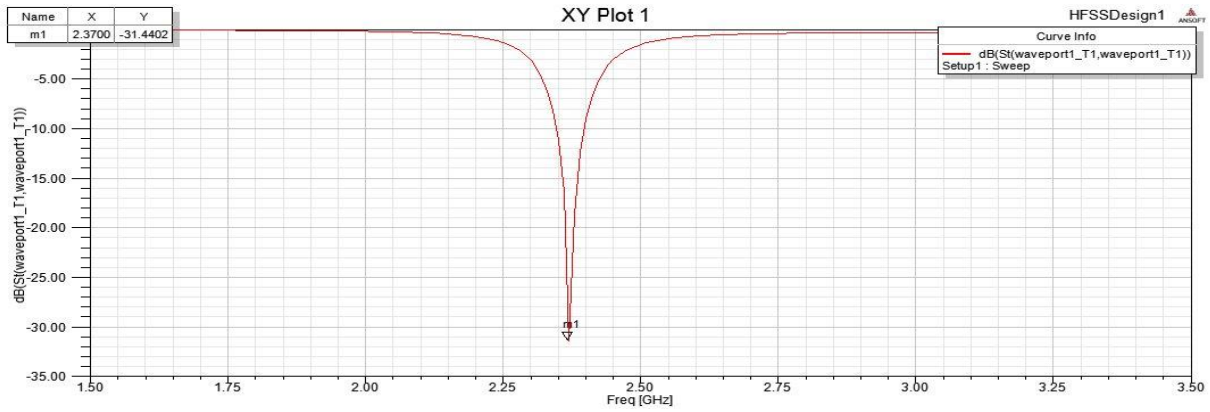

Fig 2.5: XY Plot 1(dB vs freq Plot)

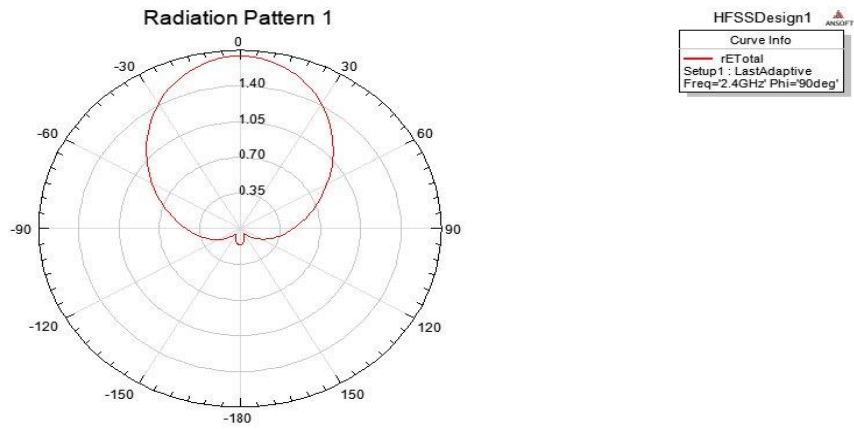

Fig 2.6: Radiation Pattern

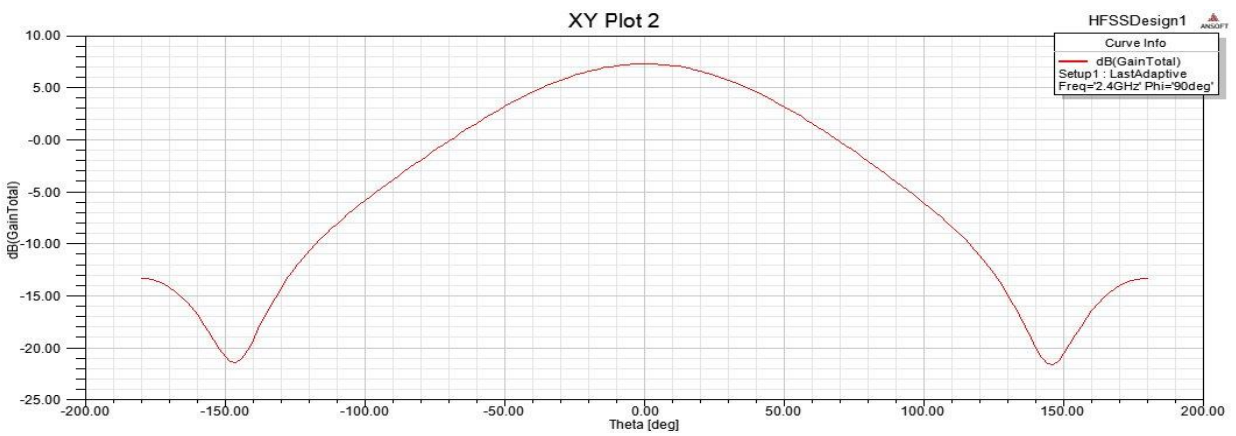

Fig2.7:XY Plot 2(dB vs Theta Plot)

CONCLUSION:

A Rectangular Microstrip Patch Antenna, resonant at frequency $f_0 = 2.4\text{GHz}$, is designed and simulated on Rogers RT/duroid 5880. The microstrip patch dimensions obtained from the simulation are used to fabricate the antenna. The simulation of rectangular Microstrip Patch antenna with coaxial probe feeding technique is performed by using HFSS software for the specific frequency of 2.4GHz.

REFERENCES:

- [1] C.A. Balanis, "*Antenna Theory Analysis and Design*", Second edition: John Wiley and Sons, Inc, 1997.
- [2] A. Asrokin, M.K.A.Rahim, M.Z.A. Abd Aziz, "*Dual Band Microstrip Antenna for WLAN Application*", Asia Pacific Applied Electromagnetics Conference (APACE 2005).
- [3] Sanjeev Kumar Sharma and Munish Rattan, "*Analysis of Broadbanding and Minimization Techniques for Square Patch Antenna*" March 25, 2011.
- [4] Masoud Sabaghi, S.Reza Hadianamrei M. Reza Kouchaki, M. sadat miri, "*C Band Wideband Single Patch E-Shaped Compact Microstrip Antenna*", International Journal of Science and Advanced Technology (ISSN 2221-8386) Volume 1 No 9, p.p. 59-63, November 2011.
- [5] T.Huynh and K.F Lee, "*Single-layer Single-patch Wideband Microstrip Antenna*", Electron. Letter Vol. 31, No. 16, pp. 1310 -1312,1995.
- [6] Kin-Lu Wong, "*Compact and Broadband Microstrip Antennas*", John Wiley and Sons, Inc., pp. 112 – 113, 2002
- [7] <http://www.antenna-theory.com/antennas/patches/antenna.php>
- [8] Asian Journal of Applied Science and Technology (AJAST) Volume 1, Issue 2, Pages 127-131, March 2017