

Home Automation Using GSM Control

by

Name	Roll No.	Registration No:
ABHIJIT MONDAL	11700314002	141170110184 of 2014-2018
SOUVIK NASKAR	11700314109	141170110184 of 2014-2018
AMAN SHAW	11700314009	141170110191 of 2014-2018
UDIT NARAYAN DAS	11700314120	141170110302 of 2014-2018

A comprehensive project report has been submitted in partial fulfillment of the requirements for the degree of

Bachelor of Technology
in
ELECTRONICS & COMMUNICATION ENGINEERING

Under the supervision of

Mrs. Arpita Banerjee (Roy)
Professor

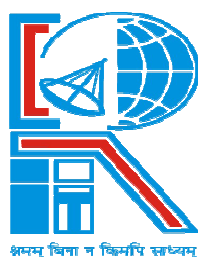

Department of Electronics & Communication Engineering
RCC INSTITUTE OF INFORMATION TECHNOLOGY
Affiliated to Maulana Abul Kalam Azad University of Technology, WestBengal
CANAL SOUTH ROAD, BELIAGHATA, KOLKATA - 700015

May,2018

CERTIFICATE OF APPROVAL



This is to certify that the project titled “**Home Automation Using GSM Control**” carried out by

Name	Roll No.	Registration No:
ABHIJIT MONDAL	11700314002	141170110184 of 2014-2018
SOUVIK NASKAR	11700314109	141170110291 of 2014-2018
AMAN SHAW	11700314009	141170110191 of 2014-2018
UDIT NARAYAN DAS	11700314120	141170110302 of 2014-2018

for the partial fulfillment of the requirements for B.Tech degree in **Electronics and Communication Engineering** from **Maulana Abul Kalam Azad University of Technology, West Bengal** is absolutely based on his own work under the supervision of **Mrs. Arpita Banerjee(Roy)**. The contents of this thesis, in full or in parts, have not been submitted to any other Institute or University for the award of any degree or diploma.

Optional in case of External Supervisor

.....

.....

.....

Dr. Abhishek Basu

Head of the Department (ECE)

RCC Institute of Information Technology

DECLARATION



“We Do hereby declare that this submission is our own work conformed to the norms and guidelines given in the Ethical Code of Conduct of the Institute and that, to the best of our knowledge and belief, it contains no material previously written by another neither person nor material (data, theoretical analysis, figures, and text) which has been accepted for the award of any other degree or diploma of the university or other institute of higher learning, except where due acknowledgement has been made in the text.”

.....
ABHIJT MONDAL

Registration No:141170110184 OF 2014-2018
Roll No: 11700314002

.....
SOUVIK NASKAR

Registration No:141170110291 OF 201-2018
Roll No: 11700314109

.....
AMAN SHAW

Registration No: 141170110191 OF 201-2018
Roll No: : 11700314009

.....
UDIT NARAYAN DAS

Registration No: 141170110302 OF 201-2018
Roll No: : 11700314120

Date: 11/5/18

Place: KOLKATA

CERTIFICATE of ACCEPTANCE



This is to certify that the project titled “**Home Automation Using GSM Control**” carried out by

Name	Roll No.	Registration No:
ABHIJIT MONDAL	11700314002	141170110184 of 2014-2018
SOUVIK NASKAR	11700314109	141170110184 of 2014-2018
AMAN SHAW	11700314009	141170110191 of 2014-2018
UDIT NARAYAN DAS	11700314120	141170110302 of 2014-2018

is hereby recommended to be accepted for the partial fulfillment of the requirements for B.Tech degree in **Electronics and Communication Engineering** from **Maulana Abul Kalam Azad University of Technology, West Bengal**

Name of the Examiner Signature with Date

1.

2.....

3.....

4.

Acknowledgement

We would like to express our special thanks of gratitude to our Supervisor Mrs. Arpita Banerjee (Roy) Electronics and Communication Engineering Department, who has given us all the necessary technical guidance in carrying out this project and,

Mr. Poddar who gave us the golden opportunity to do this wonderful project on the "Home Automation Using GSM Control", which also helped us in doing a lot of research and we came to know about so many new things. We are really thankful to them.

Secondly we would also like to thank our friends who helped us a lot in finalizing this project within the limited time frame.

Thanking you,

Yours Sincerely

ABHIJIT MONDAL

SOUVIK NASKAR

AMAN SHAW

UDIT NARAYAN DAS

ABSTRACT

Now a day's every system is automated in order to face new challenges in the Present day situation. Automated systems have less manual operations, so that the Flexibility, reliabilities are high and accurate. Hence every field prefers automated control Systems. Especially in the field of electronics automated systems are doing better Performance. Probably the most useful thing to know about the global system for mobile Communication is that it is an international standard. If you travel in parts of world, GSM is only type of cellular service available. Instead of analog services, GSM was developed as a digital system using TDMA technology. The goal of the project is to develop a system, which uses Mobile technology that keeps control of the various units of the home appliances, which executes with respect to the signal sent by the mobile. For utilization of appliances the new concept has been thought to manage them remotely by using GSM, which enables the user to remotely control switching of domestic appliances. Just by dialing keypad of remote telephone, from where we are calling we can perform ON / OFF operation of the appliances. The ranges of appliances that can be controlled through tele remote systems are many in numbers. Some of them are as follows and this depends upon the usage priority of the appliances i.e. Lights, Music System or other electrical / electronic appliances.

CONTENTS

CERTIFICATE	1
DECLARATION.....	3
CERTIFICATE of ACCEPTANCE	4
ACKNOWLEDGEMENT.....	6
ABSTRACT	7
LIST OF FIGURES.....	8
LIST OF TABLES	9
INTRODUCTION.....	10
BACKGROUND.....	11
DESCRIPTION.....	15
IC USED AND DESCRIPTION.....	19
METHODOLOGY.....	22
HOME AUTOMATION SYSTEM AND ITS WORKING	26
CONCLUSION.....	29
REFERENCE.....	30

LIST OF FIGURES

Fig 2.1	GSM Architecture	
Fig 3.1	Regulated Power Supply	
Fig 3.2	Top view of RELAY	
Fig 3.3	Bottom view of RELAY	
Fig 3.4	Crystal Oscillator	
Fig 3.5	3.5mm Earphone jack	
Fig 3.6	Step down Transformer	
Fig 4.1	CD8870 IC	
Fig 4.2	CD4067 IC	
Fig 4.3	CD4013IC	
Fig 5.1	Block diagram	
Fig 5.2	Circuit Diagram	
Fig 6.1	The Whole Home Automation Sysytem	
Fig 6.2	A call is generated	
Fig 6.3	One act is performed	
Fig 6.4	Other act is performed	
Fig 6.5	Resetting all the performance	

LIST OF TABLES

Table 2.1	GSM frequency bands	
Table 2.2.	DTMF Signals	
Table 5.1	Componenets Used	

1. Introduction

The project involves developing a system, which uses technology that keeps control of the various units of the home automated services, which executes with respect to the signal sent to the mobile. As we have the new concept has been thought to manage them remotely by using a GSM, which enables the user remotely control switching off appliances. By simply sending SMS to the modem at the remote place, the devices can be turned ON/OFF and the status of the device can be sent to the registered mobile number programmed in the microcontroller.

A smart home automation system implemented by using Global System for Mobile communication (GSM) . The hardware architecture of the system consists of GSM modem, smartphone. The system used a GSM modem to control electric appliances through Calling request. The used ICs are GSM modem and it is used to read and decode the received call to execute the specific command. Home appliances are connected via relays.. The RF Module response time is less than 500 microseconds. The whole process of sending and receiving commands is processed within 2 seconds. One of the advantages of this automated system is that users will get feedback status of household appliances via call on their smartphones. This system was implemented in hardware and achieved • 98% accuracy. Due to the wide coverage of GSM network users can get access to appliances from anywhere in the world. It is concluded that the usage of GSM in the home automation system provides maximum security and reliability

1.1 Aim of the project:

The aim of the project is to develop a system, which uses Mobile technology that keeps control of the various units of the automobiles, Computer system , which executes With respect to the signal sent by the mobile.

1.2 Significance and applications:

GSM BASED HOME AUTOMATION plays a very important role in domestic applications. The ease of operation of the kit and low cost add up as an additional advantage for its usage. Its significance can be proved by considering the following specialties of kit designed by us.

Reliability is one such factor that every electrical system should have in order to render its services without malfunctioning over along period of time. We have designed our kit using GSM which is itself very reliable and also operates very efficiently under normal condition.

Cost: The design is implemented at a very economical price. The total cost

Incurred by us in designing this kit is very less and further we have developed the **GSM Based Home Automation** which are more economical rather than just interfacing those

Which are readily available in the market. For utilization of appliances the new concept has been thought to manage them remotely by using GSM, which enables the user to remotely control switching of domestic appliances. Just by dialing keypad of remote telephone, from where you are calling you can perform ON / OFF operation of the appliances.

2. Background:

Now-a-days there is a huge advancement in the communication sector. Almost all people now-a-days have access to mobile phones and thus the world has indeed become a global village. At any given moment, any person across the world can be contacted with the help of a mobile phone. But mobile phones can not only used for the calling and sending SMS purposes but also new ideas can be generated and techniques can be developed from it that can further enhance its capabilities. There are huge technological advancements in wireless communication like Infra-red and Bluetooth which mostly took place in the recent years shows that the further improvements are in fact possible to make our life more easy and comfortable. Having wireless control of almost all the things in a person's life is a growing interest and many systems are developed providing such controls. So based on this idea we have designed a control system which is based on the GSM technology that effectively allows control from a remote area to the desired location. Because of this system, there is no need for a person to physically present to switch on/off the electrical appliances.

Here our main objective is to design a system that will enable us to have a complete control of the interface on which it is based. General objectives of the project are:

- To co-ordinate appliances and other devices through the GSM network.
- To eliminate the need of being physically present in any location for tasks involving the operation of appliances within a household/office.
- Minimize power and time wastage.
-

2.1 GSM(Global System for Mobile)TECHNOLOGY

GSM implies worldwide framework for versatile correspondence. GSM is a global advanced cell telecommunication. The GSM standard was proposed by ETSI (European Telecommunications Standard Institute) in 1989. The primary business administrations were launched in 1991 and after its initial presentation in Europe, the standard went worldwide in 1992. From that point forward GSM has turned into the most broadly embraced and quickly developing advanced standard, and it is situated to turn into the world's overwhelming cell standard.



Fig.2.1 GSM cell site antennas

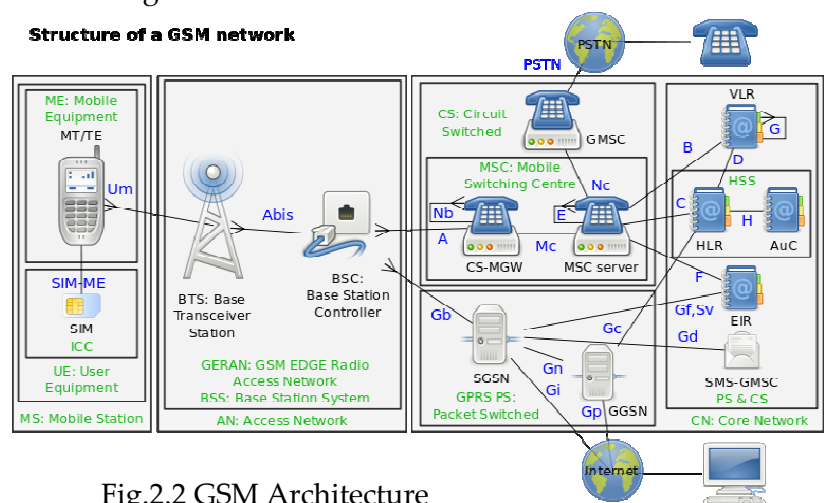

Fig.2.2 GSM Architecture

Today's third era GSM systems convey excellent and secure versatile voice and information administrations with full abilities over the world. GSM is a massively fruitful engineering and as uncommon story of worldwide accomplishment. Since the first GSM system was industrially launched, it turned into, the world's heading and fastest developing portable standard. The GSM Association evaluates that advances characterized in the GSM standard serve 80% of the worldwide portable business, including more than 5 billion individuals crosswise over more than 212 nations and domains, making GSM the most omnipresent of the numerous guidelines for cell systems. Today's GSM stage is living, developing and advancing and as of now offers an extended and characteristic-rich "family" of voice and empowering administrations. The Global System for Mobile Communication (GSM) system is cell telecommunication system with an adaptable structural planning following the ETSI Gsm900/GSM 1800 standard. Seimen's usage is the advanced cell versatile correspondence framework D900/1800/1900 that uses the precise most recent innovation to meet each prerequisite of the standard. GSM networks operate in a number of different carrier freq

uency ranges (separated into GSM frequency ranges for 2G and UMTS frequency bands for 3G), with most 2G GSM networks operating in the 900 mhz or 1800 mhz bands. Where these bands were already allocated, the 850 mhz and 1900 mhz bands were used instead (for example in Canada and the United States). In rare cases the 400 and 450 mhz frequency bands are assigned in some countries because they were previously used for first-generation systems. For comparison most 3G networks in Europe operate in the 2100 mhz frequency band. For more information on worldwide GSM frequency usage, see GSM frequency bands. Regardless of the frequency selected by an operator, it is divided into timeslots for individual phones. Half-rate channels use alternate frames in the same timeslot. The channel data rate for all 8 channels is 270.833 kbit/s, and the frame duration is 4.615 ms.

The transmission power in the handset is limited to a maximum of 2 watts in GSM 850/900 and 1 watt in GSM 1800/1900.

2.1.1 GSM security

GSM was intended to be a secure wireless system. It has considered the user authentication using a pre-shared key and challenge-response, and over-the-air encryption. However, GSM is vulnerable to different types of attack, each of them aimed at a different part of the network. GSM uses several cryptographic algorithms for security. The A5/1, A5/2, and A5/3 stream ciphers are used for ensuring over-the-air voice privacy. A5/1 was developed first and is a stronger algorithm used within Europe and the United States; A5/2 is weaker and used in other countries. Serious weaknesses have been found in both algorithms: it is possible to break A5/2 in real-time with a ciphertext-only attack, and in January 2007, The Hacker's Choice started the A5/1 cracking project with plans to use fpgas that allow A5/1 to be broken with a rainbow table attack. The system supports multiple algorithms so operators may replace that cipher with a stronger one. Since 2000 different efforts have been made in order to crack the A5 encryption algorithms. Both A5/1 and A5/2 algorithms have been broken, and their cryptanalysis has been revealed in the literature. As an example, Karsten Nohl (de) developed a number of rainbow tables (static values which reduce the time needed to carry out an attack) and have found new sources for known plaintext attacks.^[23] He said that it is possible to build "a full GSM interceptor...from open-source components" but that they had not done so because of legal concerns.^[24] Nohl claimed that he was able to intercept voice and text conversations by impersonating another user to listen to voicemail,

2.1.2 GSM frequency bands:

GSM band	f (MHz)	Uplink (MHz) (Mobile to Base)	Downlink (MHz) (Base to Mobile)	Channel number	Equivalent LTE band
T-GSM-380	380	380.2 – 389.8	390.2 – 399.8	dynamic	
T-GSM-410	410	410.2 – 419.8	420.2 – 429.8	dynamic	
GSM-450	450	450.6 – 457.6	460.6 – 467.6	259 – 293	31
GSM-480	480	479.0 – 486.0	489.0 – 496.0	306 – 340	
GSM-710	710	698.2 – 716.2	728.2 – 746.2	dynamic	12
GSM-750	750	777.2 – 792.2	747.2 – 762.2	438 – 511	
T-GSM-810	810	806.2 – 821.2	851.2 – 866.2	dynamic	27
GSM-850	850	824.2 – 848.8	869.2 – 893.8	128 – 251	5
P-GSM-900	900	890.0 – 915.0	935.0 – 960.0	1 – 124	
E-GSM-900	900	880.0 – 915.0	925.0 – 960.0	975 – 1023, 0 - 124	8
R-GSM-900	900	876.0 – 915.0	921.0 – 960.0	955 – 1023, 0 - 124	
T-GSM-900	900	870.4 – 876.0	915.4 – 921.0	dynamic	
DCS-1800	1800	1710.2 – 1784.8	1805.2 – 1879.8	512 – 885	3
PCS-1900	1900	1850.2 – 1909.8	1930.2 – 1989.8	512 – 810	2

Table:2.1

2.2 DTMF (Dual Tone Multi Frequency)

Dual-tone multi-frequency signaling (DTMF) is an in band telecommunication signaling system using the voice-frequency band over telephone lines between telephone equipment and other communications devices and switching centers. DTMF was first developed in the Bell System in the United States, and became known under the trademark **Touch-Tone** for use in push-button telephones supplied to telephone customers, starting in 1963. The main principle of the DTMF is that it takes a number code from the number pad converts it to DTMF (Dual tone multi frequency) signal and a DTMF decoder converts the DTMF signal to a digital code that can be fed to a microcontroller. A DTMF generator generates two frequencies corresponding to a number or code in the number pad which is transmitted through the communication networks, constituting the transmitter section which is simply equivalent to a mobile set. The DTMF frequencies representing the number codes is shown below.

1	2	3	A	697 Hz
4	5	6	B	770 HZ
7	8	9	C	852 Hz
*	0	#	D	941 Hz
1209 Hz	1336 Hz	1477Hz	1633 Hz	

Table 2.2

DTMF generation is a composition of two audio signals or two tones between the frequency 697Hz and 1633Hz. In a DTMF each row has its own unique tone frequency and also each column will have its own unique tone. The tone frequencies are selected such that harmonics and inter modulation products will not cause any unreliable signal. Each and every tone falls within a proper band pass before valid decoding takes place. If one tone falls outside the band pass spectrum, the decoder will become unreliable. A DTMF decoders main purpose is to detect the sinusoidal signals in the presence of noise.

3.Description

In this project we are going to control general home appliances based on the mobile communication. The idea behind this particular work is to give user the full flexibility to control the appliances from remote distances when there is a busy schedule concerned to his daily routine.

The main parts of this schematic diagram are:

1. POWER SUPPLY.
2. GSM CONTROL UNIT.
3. DTMF CD8870
4. MOBILE CONNECTOR 3.5mm Jack
5. RELAYS
6. BULB CIRCUIT
7. DC MOTOR CIRCUIT.

The process to operate this project is first make a mobile to mobile connection wirelessly or with a single mobile onboard wired. But here we are using to mobiles to make is a wireless application. Start with making a connection with the onboard mobile from remote distance, then when connection is established lets control the project with

The data as follows:

To operate the BULB just press "*" and then "4" respectively to switch ON and also to switch OFF again, Press "*" and then "4" respectively. This ON/OFF condition of BULB is through Relay where switching is very Fast and accurate. To operate the PUMP just press "*" and then "8" respectively to switch ON and also to switch OFF again, Press "*" and then "4" respectively .This ON/OFF condition of PLUG is through Relay where switching is very Fast and accurate.

3.1REGULATED POWER SUPPLY

A variable regulated power supply, also called a variable bench power supply, is one where you can continuously adjust the output voltage to your requirements. Varying the output of the power supply is the recommended way to test a project after having double checked parts placement against circuit drawings and the parts placement guide. This type of regulation is ideal for having a simple variable bench power supply. Actually this is quite important because one of the first projects a hobbyist should undertake is the construction of a variable regulated power supply. While a dedicated supply is quite handy e.g. 5V or 12V, it's much handier to have a variable supply on hand, especially for testing. Most digital logic circuits and processors need a 5 volt power supply.

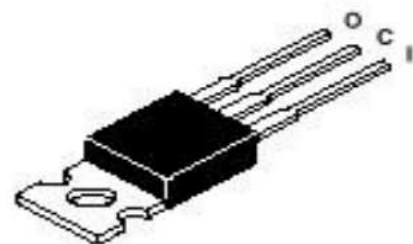
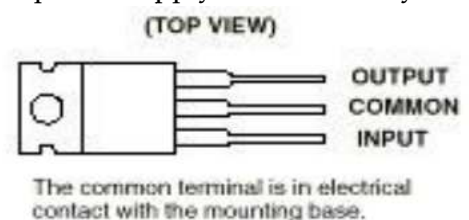

Fig 3.1

3.2 Relay

A **relay** is an electrically operated switch. Many relays use an electromagnet to mechanically operate a switch, but other operating principles are also used, such as solid-state relays. Relays are used where it is necessary to control a circuit by a separate low-power signal, or where several circuits must be controlled by one signal. The first relays were used in long

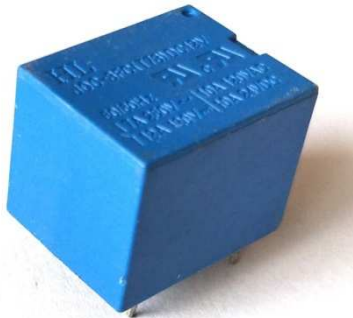

Fig. 3.2

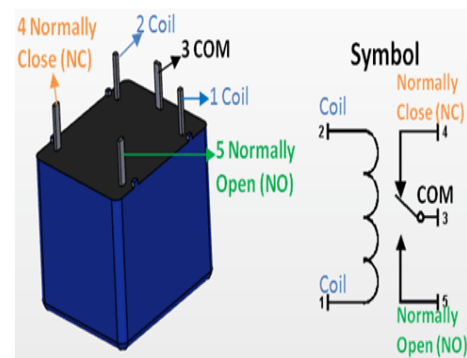

Fig 3.3

distance telegraph circuits as amplifiers: they repeated the signal coming in from one circuit and re-transmitted it on another circuit. Relays were used extensively in telephone exchanges and early computers to perform logical operations.

Features of 5V relay

- Trigger Voltage (Voltage across coil) : 5V DC
- Trigger Current (Nominal current) : 70mA
- Maximum AC load current: 10A @ 250/125V AC
- Maximum DC load current: 10A @ 30/28V DC
- Compact 5-pin configuration with plastic moulding
- Operating time: 10msec Release time: 5msec
- Maximum switching: 300 operating/minute (mechanically)

Relays are most commonly used switching device in electronics.

For the circuit to drive the relay we have two important parameter of the relay. One is the Trigger Voltage, this is the voltage required to turn on the relay that is to change the contact from Common->NC to Common->NO. Our relay here has 5V trigger voltage, but relays of values 3V, 6V and even 12V are found. The other parameter is the Load Voltage & Current, this is the amount of voltage or current that the NC,NO or Common terminal of the relay could withstand, in our case for DC it is maximum of 30V and 10A.

Since the relay has 5V trigger voltage we have used a +5V DC supply to one end of the coil and the other end to ground through a switch. This switch can be anything from a small transistor to a microcontroller or a microprocessor which can perform switching operating. A diode connected across the coil of the relay, this diode is called the Fly back Diode. The purpose of the diode is to protect the switch from high voltage spike that can produced by the relay coil. As shown one end of the load can be connected to the Common pin and the other end is either connected to NO or NC. If connected to NO the load remains disconnected before trigger and if connected to NC the load remains connected before trigger

- **Applications of Relay**

Commonly used in used in switching circuits. For Home Automation projects to switch AC loads to Control (On/Off) Heavy loads at a pre-determined time/condition Used in safety circuits to disconnect the load from supply in event of failure Used in Automobiles electronics for controlling indicators glass motors etc.

3.3 CRYSTAL OSCILLATOR

A **crystal oscillator** is an electronic oscillator circuit that uses the mechanical resonance of a vibrating crystal of create an electrical signal with a precise frequency. A crystal oscillator, particularly one made of quartz crystal, works by being distorted by an electric field when voltage is applied to an electrode near or on the crystal. This property is known as electrostriction or inverse piezoelectricity. When the field is removed, the quartz – which oscillates in a precise frequency - generates an electric field as it returns to its previous shape,



Fig3.4

and this can generate a voltage. The result is that a quartz crystal behaves like an RLC circuit.

Quartz crystals are manufactured for frequencies from a few tens of kilohertz to hundreds of megahertz. In our project we have used 3.579 MHz crystal oscillator.

3.4 3.5mm earphone jack: In this project we have used a 3.5mm earphone jack for transferring the signal. We have taken its one port as a signal and ground part.



Fig. 3.5

3.5 STEP DOWN TRANSFORMER:

A step down transformer is designed to reduce electrical voltage. Its primary voltage is greater than the secondary voltage. This kind of transformer "steps down" the voltage applied to it. For instance, a step down transformer is needed to use a 110v product in a country with a 220v supply. This kind of electrical transformer are made from two or more coils of insulated wire wound around a core made of iron. When voltage is applied to one coil



Fig 3.6

(frequently called the primary or input) it magnetizes the iron core, which induces a voltage in the other coil, (frequently called the secondary or output). The turns ratio of the two sets of windings determines the amount of voltage transformation. An example of this would be: 100 turns on the primary and 50 turns on the secondary, a ratio of 2 to 1. With this type of transformer, the voltage ratio between primary and secondary will mirror the "turns ratio" (except for single phase smaller than 1 kva which have compensated secondaries). A practical application of this 2 to 1 turns ratio would be a 480 to 240 voltage step down. Note that if the input were 440 volts then the output would be 220 volts. The ratio between input and output voltage will stay constant. Transformers should not be operated at voltages higher than the nameplate rating, but may be operated at lower voltages than rated. Because of this it is possible to do some non-standard applications using standard transformers. A Single phase transformer like this, 1 kva and larger, may also be reverse connected to step-down or step-up voltages.

4 IC USED AND DESCRIPTION

IC CD 8870

Features

- Complete DTMF Receiver
- Low power consumption
- Internal gain setting amplifier
- Adjustable guard time
- Power-down mode
- Inhibit mode
- Backward compatible with MT8870

Applications

- Receiver system for British Telecom (BT) or CEPT Spec (MT8870D-1)
- Repeater systems/mobile radio
- Credit card systems
- Remote control

Dual-tone multi-frequency signaling (DTMF) is an in-band telecommunication signaling system using the voice-frequency band over telephone lines between telephone equipment and other communications devices and switching centers. DTMF was first developed in the Bell System in the United States, and became known under the trademark Touch-Tone for use in push-button telephones supplied to telephone

Functional Description

- The MT8870 monolithic DTMF receiver offers small size, low power consumption and high performance. Its architecture consists of a bandsplit filter section, which separates the high and low group tones, followed by a digital counting section which verifies the frequency and duration of the received tones before passing the corresponding code to the output bus. Filter Section Separation of the low-group and high group tones is achieved by applying the DTMF signal to the inputs of two sixth-order switched capacitor bandpass filters, the bandwidths of which correspond to the low and high group frequencies. The filter section also incorporates notches at 350 and 440 Hz for exceptional dial tone rejection . Each filter output is followed by a single order switched capacitor filter section which smooths the signals prior to limiting. Limiting is performed by high-gain comparators which are provided with hysteresis to prevent detection of unwanted low-level signals. The outputs of the comparators provide full rail logic swings at the frequencies of the incoming DTMF signals.

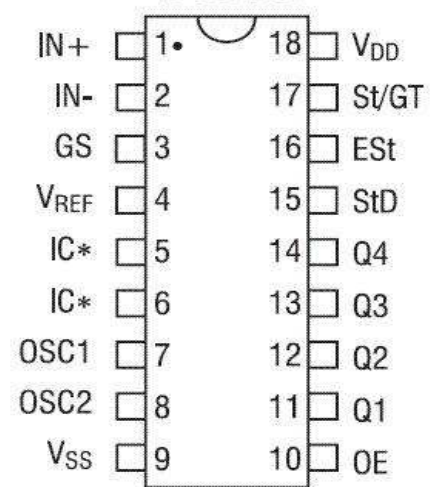

Fig 4.1

- pin1 is a non inverting pin, which is connected to the pin 4.
- Pin3 is the output of the operational amplifier, which is feedback to the pin 2.
- The pin 7 and pin 8 is connected to the crystal oscillator of both pins.
- Pin 15 is the data interconnection pin.
- The procedure of the signal from the frequency detection to digitalization, is done steering circuit that consists of resistor, capacitors, receiver and transmitter and etc.
- 11, 12 pins are output pins that are connected DTMF pins. Then DTMFis connected to relay.
- Relay output is connected pb0 and pb3 pins of microcontrollers.
- PD0, PD1 are output pins of controller, that are connected to the relays.
- Relay output is connected to the load.

IC CD-4067

General description

The 74HC4067; 74HCT4067 is a single-pole 16-throw analog switch (SP16T) suitable for use in analog or digital 16:1 multiplexer/demultiplexer applications. The switch features four digital select inputs (S0, S1, S2 and S3), sixteen independent inputs/outputs (Yn), a common input/output (Z) and a digital enable input (E). When E is HIGH, the switches are turned off. Inputs include clamp diodes. This enables the use of current limiting resistors to interface inputs to voltages in excess of VCC. 2.

Features and benefits

Input levels S0, S1, S2, S3 and E inputs:

For 74HC4067: CMOS level

For 74HCT4067: TTL level

Low ON resistance:

80 Ω (typical) at VCC = 4.5 V

70 Ω (typical) at VCC = 6.0 V

60 Ω (typical) at VCC = 9.0 V

Applications

Analog multiplexing and demultiplexing

Digital multiplexing and demultiplexing

Signal gating

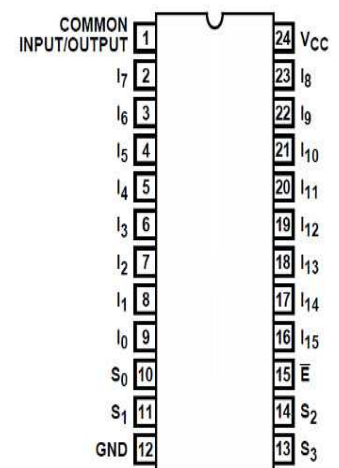

Fig 4.2

IC CD-4013

Description

The CD4013 device consists of two identical, independent data-type flip-flops. Each flip-flop has independent data, set, reset, and clock inputs and Q and \bar{Q} outputs. These devices can be used for shift register applications, and, by connecting Q output to the data input, for counter and toggle applications. The logic level present at the D input is transferred to the Q output during the positive-going transition of the clock pulse. Setting or resetting is independent of the clock and is accomplished by a high level

on the set or reset line, respectively. The CD4013B types are supplied in 14-pin dual-inline plastic packages ,

14-pin small-outline package , and 14-pin thin shrink small-outline packages .

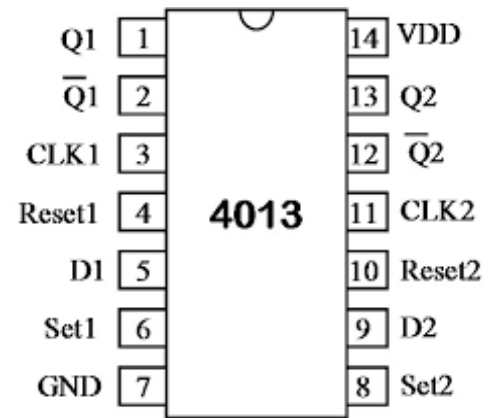

Fig.4.3

Application Information

A high level at the SET or RESET inputs sets or resets the outputs, regardless of the levels of the other inputs. When SET and RESET are inactive (low), data at the data (D) input meeting the setup time requirements is transferred to the outputs on the positive-going edge of the clock pulse. Clock triggering occurs at a voltage level and is not related directly to the rise time of the clock pulse. Following the hold-time interval, data at the D input can be changed without affecting the levels at the outputs. The resistor and capacitor at the RESET pin are optional. If they are not used, the RESET and SET pin must be connected directly to ground to be inactive.

5. METHODOLOGY

5.1. CIRCUIT DESIGN AND PROCEDURE

The block diagram of our project is shown below in the fig3.1.0. It is an outline description of how we have implemented our project and the various steps involved in it. From the block diagram given below, the first mobile station is used as a transmitting section from which the user sends a code that contains commands and instructions to the second mobile station which is based on a specific area where our control system is located, through GSM network. The received code can be in either DTMF format which is send to the DTMF decoder connected via headset jack of the phone or through an SMS.

The DTMF decoder converts it into digital signal and sends it to the microcontroller interfaced to it. Then the microcontroller processes the code and carries out the specific operations. The ULN2003 is used to drive the relay circuits which switches the different appliances connected to the interface.

After connecting the circuit properly and assuming all the connections are right the following steps are to be followed:

- The remote user send authenticated signal including commands to the receiver phone.
- Through the GSM network the signal is received by the receiver phone on the device.
- Then that DTMF signal is passed to the DTMF decoder to convert it to the digital signal, and it sends them to 4013.
- 4013 commands to the appliances and the devices connected will switch ON/OFF.

5.2. Block Diagram

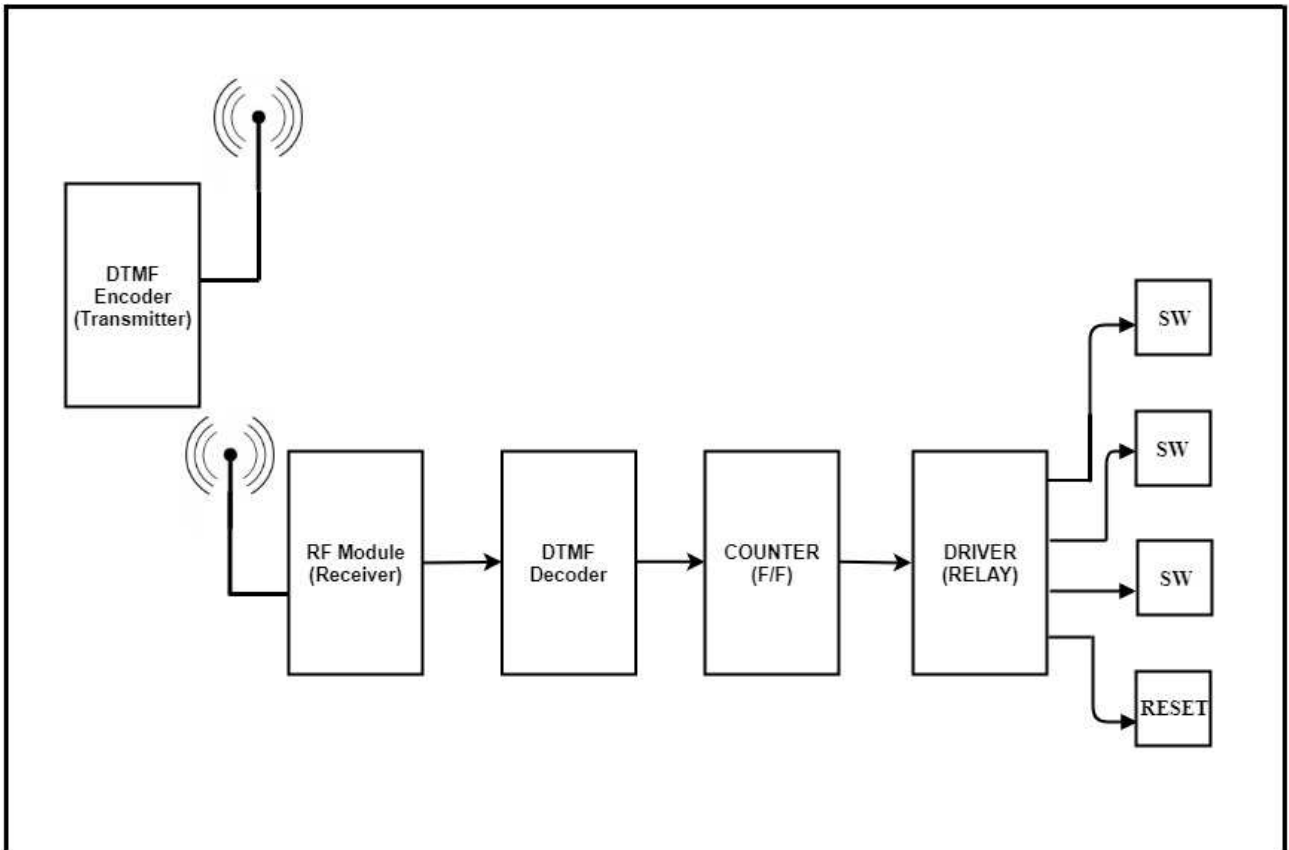

Fig. 5.1

5.3. Circuit Diagram:

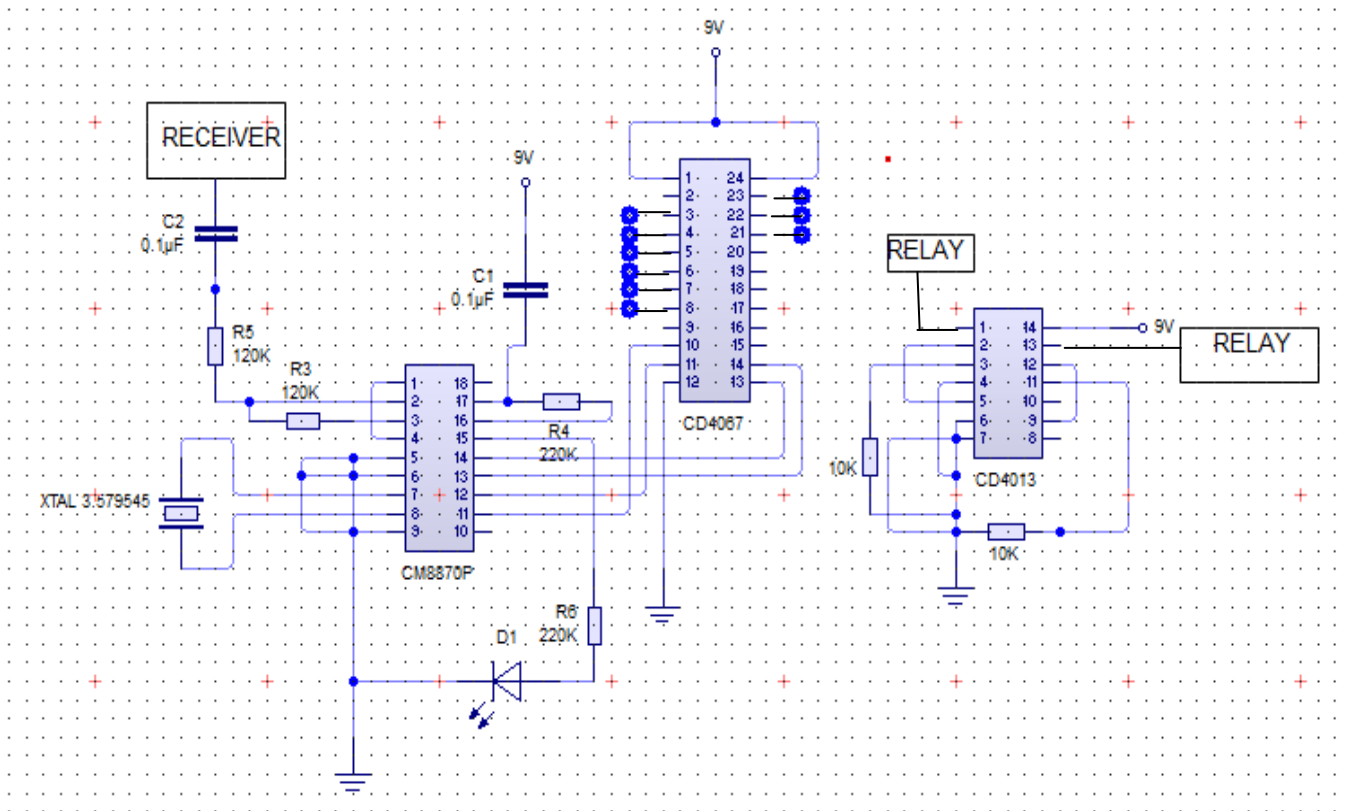

Fig. 5.2

5.4. Components Used

<u>Name</u>	<u>Capacity</u>	<u>Quantity</u>	<u>Code</u>
Binary to Decimal Conversion IC	24Pins	1	CD4067
D Flip Flop IC	14 Pins	1	CD4013
Decoder IC	18Pins	1	CM8870P
Capacitor	1000 μ f	1	C4
Capacitor	10 μ f	1	C1
Capacitor	0.1 μ f	1	C2,C3
Diode		2	D1,D2
Mobile Phone		2	
Oscillator	3.579545mhz	1	X1
Resistance	220 Ω	1	R7
Resistance	1k	2	R6
Resistance	10k	4	R3,R7,R8,R9
Resistance	120k	2	R4,R5
Relay		2	

Table 5.1

6.Home Automation System and its Working Procedure

In previous days, the home applications are controlled by manually using switches. Now a day, many technologies are available to control home appliances. This project mainly discusses DTMF decoder circuit to control the home applications. The working procedure of this project is just like dialing a customer care number using DTMF technology by following automatic voice recorded instructions. It will ask to press 1,2 or any other number when you press number to your mobile one particular procedure is happening. This is called a DTMF technology. If any button is pressed on the mobile phone keypad, then it will generate two frequencies. These tones are called row are column frequencies. Normally row frequencies are low frequencies and column frequencies are high frequencies. These column frequencies are slightly louder than the row frequencies to compensate for the high-frequency roll off of voice audio systems. The main objective of this project is to control the home applications like light, electric fan or some electronic gadgets by using DTMF techniques. DTMF encoder is present in mobile and the DTMF decoder circuit is present in the ICs. The mobile is connected at one end of the circuit with the help of the mobile phone jack. The mobile jack is consisting of two wires. The red wire is connected to the decoder IC and Black is grounded. When a button is pressed from mobile it generates a tone which is decoded by the decoder IC and it's sent to the micro controller. The controller checks the inputs and delivers the respective outputs according to the code written on it.

6.1. FLOWCHART

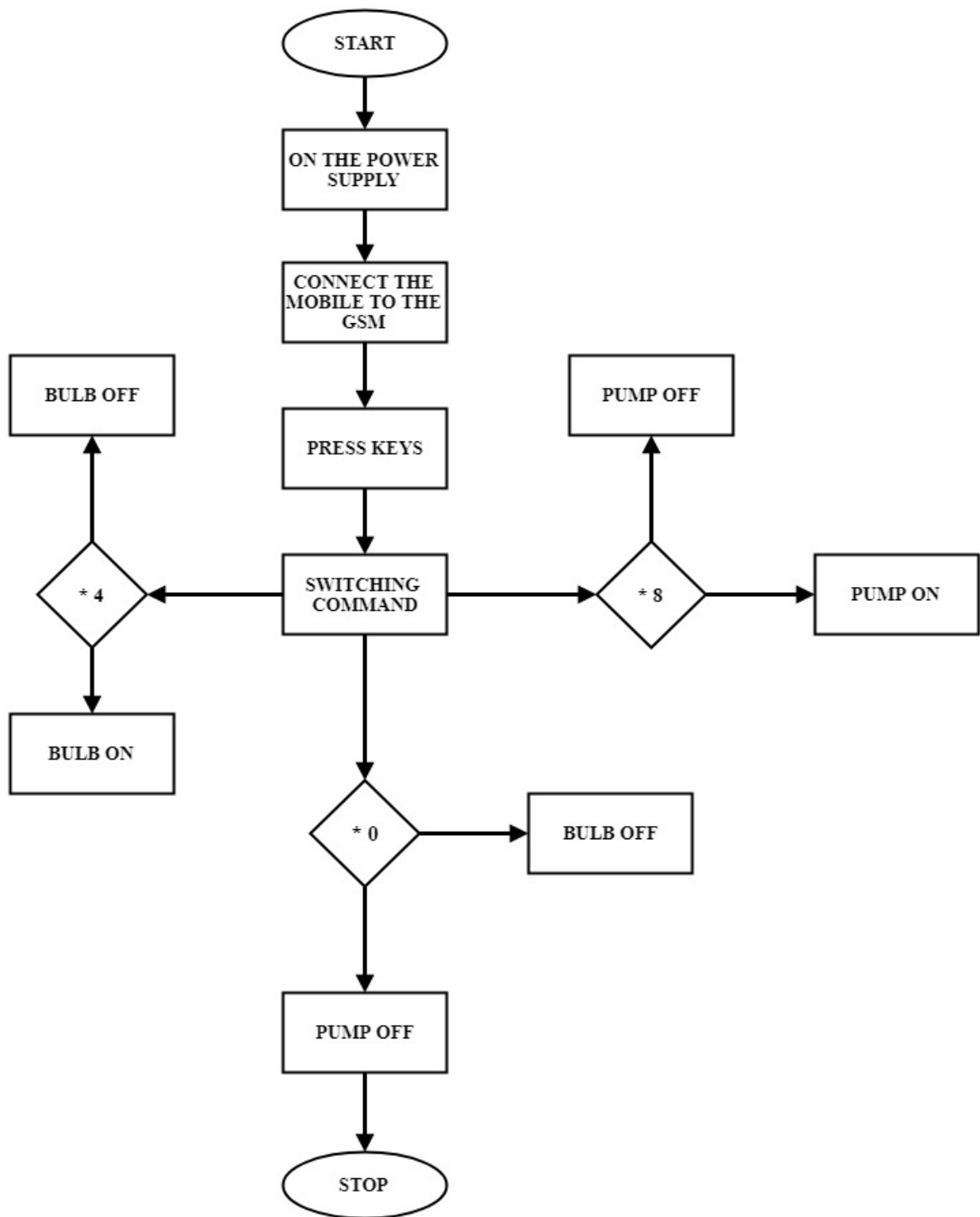

From the flowchart it states that first the user have to power ON the ckt then have to connect the GSM Module using a 3.5mm jack, which will transfer the signal. once it connected we have to make a call to the RF Module i.e. The receiver . And now the full system is connected and we have to send the signal. As we have configure some values for exact performance. Like we have configure the "*" for initialization. Then press 4 for lighting On the bulb and press 8 for switching the pump. In any case if we forget to switching On or Off the system then we have set a Reset value for this. It will be performed by "*" "8" respectively.

The whole performance is shown in this picture below,



Fig. 6.1



Fig. 6.2

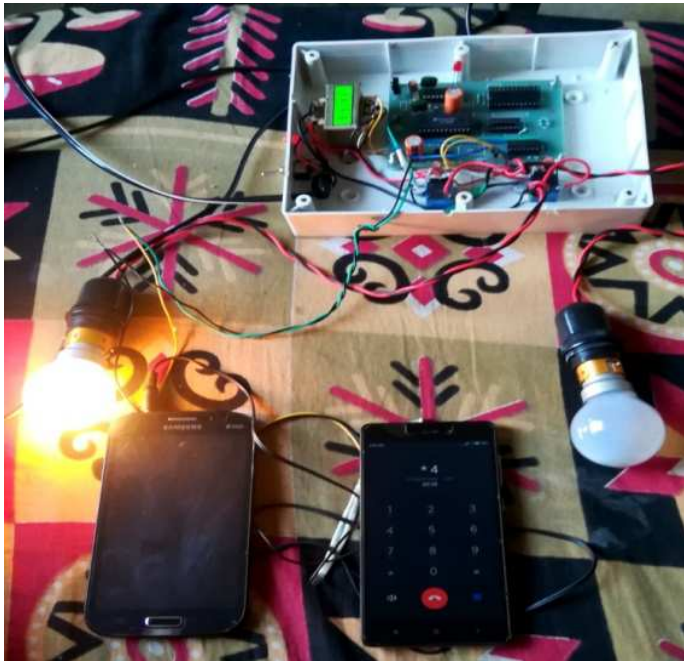

Fig. 6.3

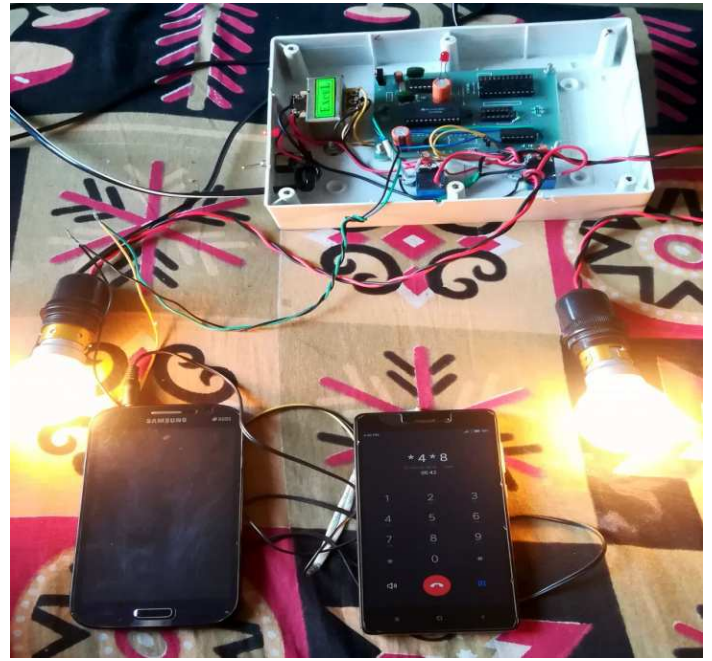

Fig. 6.4

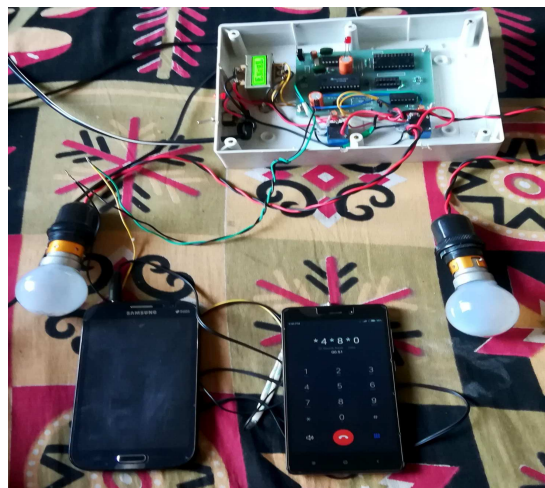

Fig. 6.5

7. CONCLUSION

The project "GSM BASED HOME AUTOMATION" has been successfully designed and tested for providing a smart and efficient way to control our home appliances with the help of modern communication technology. With the combination of ICs and GSM this project is not only a modern approach to next generation home but also a very friendly and easy to use system.. Integrating features of all the hardware components used have developed it. Presence of every module has been reasoned out and placed carefully thus contributing to the best working of the unit. Secondly, using highly advanced IC's and with the help of growing technology the project has been successfully implemented.

In this era when the number of mobile phone users growing at a high rate, this system makes use of the mobile networks to provide the users with a simple and cheap Home Automation System. GSM and IC Based systems are emerging as a technology with high potential. In the past decades micro processor based embedded system ruled the market. The last decade witnessed the revolution of Microcontroller based embedded systems.. With regards to the requirements gathered the manual work and the complexity in counting can be achieved with the help of electronic devices

8. References

- An Introduction to Mobile Networks and Mobile by Martin Sauter
- Principles and Applications of GSM by Vijay K. Garg
- R. Teymourzadeh, S. A. Ahmed, K. W. Chan, and M. V. Hoong, "Smart GSM based Home Automation System," in 2013 IEEE Conference on Systems, Process Control (ICSPC), Kuala Lumpur, Dec. 2013, pp. 306– 309.