

# SPEED CHECKER ON HIGHWAY TO PREVENT RUSH DRIVING

*by*

Name	Roll No.	Registration No:
<b>Priyanka Roy</b>	<b>11700314062</b>	<b>141170110244 of 2014-2018</b>
<b>Satyajit Roy</b>	<b>11700314085</b>	<b>141170110267 of 2014-2018</b>
<b>SK Sahanoor Hossain</b>	<b>11700314100</b>	<b>141170110282 of 2014-2018</b>
<b>Dipayan Basu</b>	<b>11700314039</b>	<b>141170110211 of 2014-2018</b>

*A comprehensive project report has been submitted in partial fulfillment of the requirements for the degree of*

## **Bachelor of Technology** *in* **ELECTRONICS & COMMUNICATION ENGINEERING**

*Under the supervision of*

**Mrs. Arpita Ghosh**

Assistant Professor



**Department of Electronics & Communication Engineering**  
**RCC INSTITUTE OF INFORMATION TECHNOLOGY**  
**Affiliated to Maulana Abul Kalam Azad University of Technology,**  
**WestBengalCANAL SOUTH ROAD, BELIAGHATA, KOLKATA - 700015**

## **CERTIFICATE OF APPROVAL**



This is to certify that the project titled “**SPEED CHECKER ON HIGHWAY TO PREVENT RUSH DRIVING**” carried out by

Name	Roll No.	Registration No:
<b>Priyanka Roy</b>	<b>11700314062</b>	<b>141170110244 of 2014-2018</b>
<b>Satyajit Roy</b>	<b>11700314085</b>	<b>141170110267 of 2014-2018</b>
<b>SK Sahanoor Hossain</b>	<b>11700314100</b>	<b>141170110282 of 2014-2018</b>
<b>Dipayan Basu</b>	<b>11700314039</b>	<b>141170110211 of 2014-2018</b>

for the partial fulfillment of the requirements for B. Tech degree in **Electronics and Communication Engineering** from **Maulana Abul Kalam Azad University of Technology, West Bengal** is absolutely based on his own work under the supervision of Mrs. **Arpita Ghosh**. The contents of this thesis, in full or in parts, have not been submitted to any other Institute or University for the award of any degree or diploma.

-----  
**Dr. Abhishek Basu**

Head of the Department (ECE)  
RCC Institute of Information Technology

-----  
**Mrs. ARPITA GHOSH**

Professor , Dept. of ECE  
RCC Institute of Information Technology

## DECLARATION



“We Do hereby declare that this submission is our own work conformed to the norms and guidelines given in the Ethical Code of Conduct of the Institute and that, to the best of our knowledge and belief, it contains no material previously written by another neither person nor material (data, theoretical analysis, figures, and text) which has been accepted for the award of any other degree or diploma of the university or other institute of higher learning, except where due acknowledgement has been made in the text.”

.....  
**PRIYANKA ROY**

Registration No:141170110244 OF 2014-2018  
 Roll No: 11700314062

.....  
**SATYAJIT ROY**

Registration No:141170110267 OF 2014-2018  
 Roll No: 11700314085

.....  
**SK SAHANOOR HOSSAIN**

Registration No:141170110282 OF 2014-2018  
 Roll No: 11700314100

.....  
**DIPAYAN BASU**

Registration No:141170110211 OF 2014-2018  
 Roll No: 11700314039

Date:

Place:

## CERTIFICATE of ACCEPTANCE



This is to certify that the project titled “SPEED CHECKER ON HIGHWAY TO PREVENT RUSH DRIVING” carried out by

Name	Roll No.	Registration No:
<b>Priyanka Roy</b>	<b>11700314062</b>	<b>141170110244 of 2014-2018</b>
<b>Satyajit Roy</b>	<b>11700314085</b>	<b>141170110267 of 2014-2018</b>
<b>SK Sahanoor Hossain</b>	<b>11700314100</b>	<b>141170110282 of 2014-2018</b>
<b>Dipayan Basu</b>	<b>11700314039</b>	<b>141170110211 of 2014-2018</b>

is hereby recommended to be accepted for the partial fulfillment of the requirements for B.Tech degree in Electronics and Communication Engineering from Maulana Abul Kalam Azad University of Technology, West Bengal

Name of the Examiner Signature with Date

1. ....

2.....

3.....

# CONTENT

<b>SERIAL NO.</b>	<b>TITLE</b>	<b>PAGE NO.</b>
1	Abstract	6-7
2	Proposed Model	8-9
3	555 timer operating mode	9-10
4	Construction Diagram	10-11
5	Hardware Requirement	12
6	Circuit Diagram	13
7	Circuit Description	14-15
8	Circuit Operation	15-16
9	Formula	16
10	Steps of Operation	17
11	NE 555 Timer	18-23
12	IC-CD 4026	24-25
13	IC-CD 4011	25-27
14	7- Segment Display	27-29
15	Buzzer	30
16	Application	31
17	Conclusion	31

## **ABSTRACT :**

The aim of this project is to develop a device to detect rash driving on highways and to alert the traffic authorities in case of any speed violation.

Accidents due to rash driving on highways are on the rise and people are losing their lives because of others mistakes.

While driving on highways, drivers should not exceed the maximum speed limit permitted for their vehicle.

However, accidents keep on occurring due to speed violations as drivers follow their speedometers and control their speed according to them, and reduce the speed if they find it to be exceeding and beyond their control.

A highway speed checker comes handy for the traffic police, especially against the speed limit violators because it provides the digital display as well as buzzing sound or alarm to detect any vehicle speed if the vehicle exceeds the permitted speed limit.

To overcome this problem, we have implemented a circuit called as a speed checker for highways. This kit is inexpensive and it is used for considering the average and high speed of vehicles that move on the highways or roads.

By taking all these considerations in mind, we have designed a highway- speed checker circuit to detect the rash driving by using different electronic components such as timer, counter, logic gates, microcontroller , seven segment display and all other components. There is one death in every 4 minutes due to road accident in India.

As we know, each and every life is important so to stop this rush driving control is needed.

In previous years, many people has worked on it or still working to stop this life taking accident.

This speed checker will come handy for the highway traffic police as

it will not only provide a digital display in accordance with a vehicle's speed but also sound an alarm if the vehicle exceeds the permissible speed for the highway.

The system displays the time taken by the vehicle in crossing this 100m distance from one fixed point to the other in 6 second, from which the speed of the vehicle can be calculated.

Thus we can also get a idea of the speed of each and every vehicle that is crossing over that road.

This speed checker will come handy for the highway traffic police as it will not only provide a digital display in accordance with a vehicle's speed but also sound an alarm if the vehicle exceeds the permissible speed for the highway.

The system displays the time taken by the vehicle in crossing this 100m distance from one pair to the other with 6 second, from which the speed of the vehicle can be calculated.

## **PROPOSED MODEL :**

In this section, we have designed a highway speed checker circuit to detect the rash driving using different electronic components such as timer, counter, logic gates, seven segment display and all other components.

Figure in below shows the typical block diagram of speed checker to detect rash driving on highways using a Timer which consists of sensor module, logical module, power supply, sound detector and display module.

Further logical module comprises timers, NAND gates and decade counters.

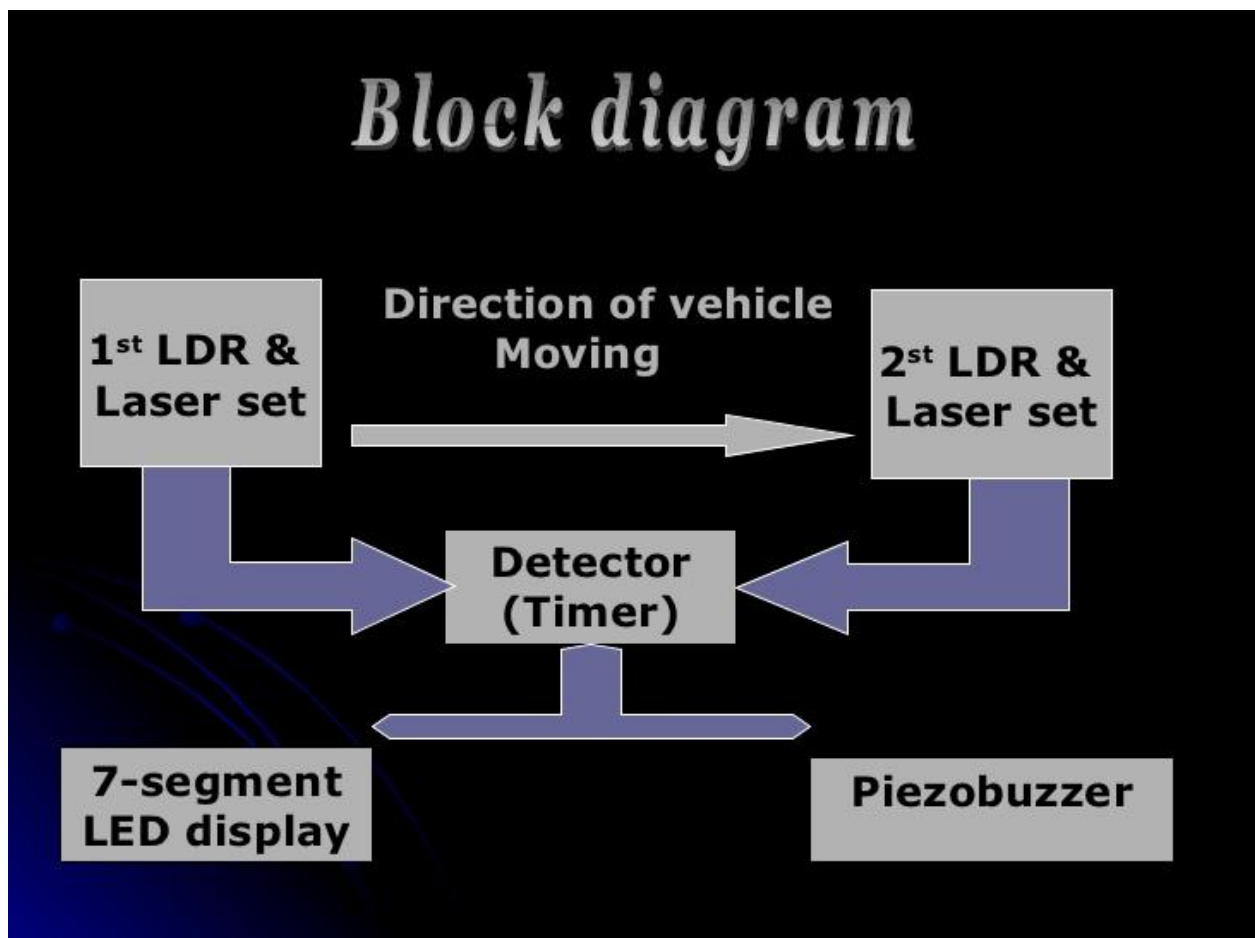



Here we used two Pair of Pointed Laser Light and Light Detecting Resister (LDR). Which is placed a certain distance in highway. From pointed Laser light laser continuously fall on LDR . Resistance of the LDR is inversely proportional to intensity of light. Whenever any vehicle cross the first pair of LDR and laser light there is an interruption between LDR and laser light, then resistance will be high and time count will start at seven segment display.

## **The 555 has three operating modes:**

**Monostable mode:** in this mode, the 555 functions as a "one-shot". Applications include timers, missing pulse detection, bounce free switches, touch switches, frequency divider, capacitance measurement, pulse-width modulation (PWM) etc. **Astable - free running mode:** the 555 can operate as an oscillator.

Uses include LED and lamp flashers, pulse generation, logic clocks, tone generation, security alarms, pulse position modulation, etc.

**Bistable mode or Schmitt trigger:** the 555 can operate as a flip-flop, if the DIS pin is not connected and no capacitor is used. Uses include bounce free latched switches, etc.

The circuit uses standard power supply comprising of a step-down transformer from 230v to 12v and four diodes forming a bridge rectifier that delivers pulsating dc which is then filtered by an electrolytic capacitor of 1000 $\mu$ f.

The filtered dc being unregulated IC LM7812 is used to get 12v constant output at its pin no 3 irrespective of input dc varying from 9v to 14v.

The input dc shall be varying in the event of input ac at 230volts section varies in the ratio of  $v_1/v_2=n_1/n_2$ . The regulated 12volts dc is further filtered by a small electrolytic capacitor of 0.1  $\mu$ f for any noise so generated by the circuit.

This is used as the supply for different ICs in the circuit. A buzzer or beeper is an audio signaling device, which may be driven by an oscillating electronic circuit or other audio signal source, driven with a piezoelectric audio amplifier.

Sounds commonly used to indicate that a button has been pressed are a click, a ring or a beep. Here, piezo-buzzer sounds an alarm if the vehicle crosses the distance between the IR Diode set-ups at more than the selected speed.

Fig. 3 shows the theory of buzzer so as to emit the sound. Simultaneously, the time taken by the vehicle to cross both the IR Diode beams is displayed on the 7-segment display.

### **Construction Diagram :**

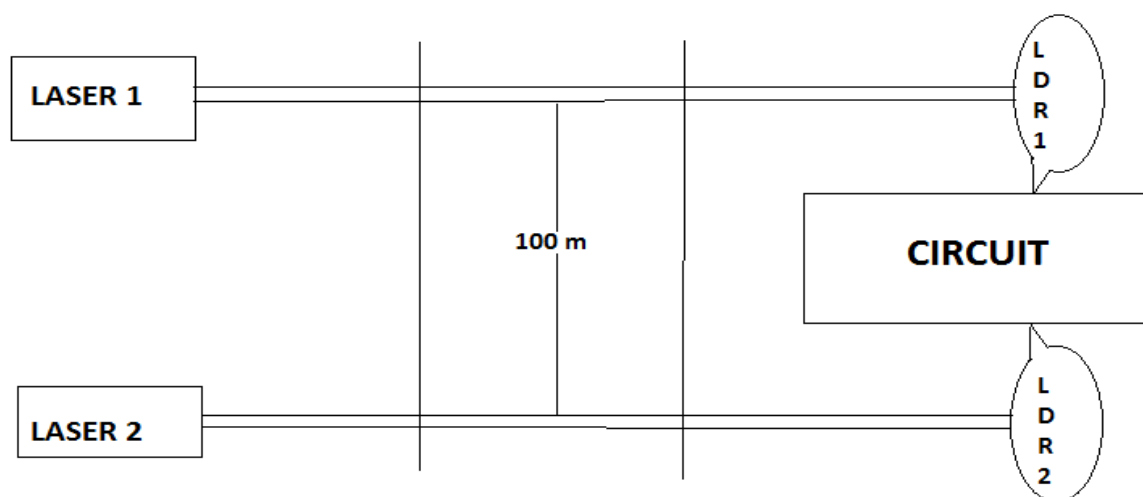

The system basically comprises two laser transmitter-LDR sensor pairs, which are installed on the highway 100 metres apart, with the transmitter and the LDR sensor of each pair on the opposite sides of the road.

The installation of lasers and LDRs is shown in Figure above.

The system displays the time taken by the vehicle in crossing this 100m distance from one pair to the other with a resolution of 0.01 second, from which the speed of the vehicle can be calculated as follows.

The main purpose of this system is to develop a speed checker for highways to alert the traffic authorities in case of any speed violation.

Many passengers and drivers, including commuters have lost their lives due to rash and rude driving on highways.

In olden days, for detecting rash driving, highway police used to target vehicles by using radar guns at the vehicle and would record their speeds.

If a vehicle would exceed its speed, automatically the information would reach to the nearest police station for controlling the speed of the vehicle. Due to this system a lot of time would get wasted.

Now everything changed by Speed Checker

While driving on highways, motorists should not exceed the maximum speed limit permitted for their vehicle.

However, accidents keep occurring due to speed violations since the drivers tend to ignore their speedometers.

This speed checker will come handy for the highway traffic police as it will not only provide a digital display in accordance with a vehicle's speed but also sound an alarm if the vehicle exceeds the permissible speed for the highway.

## **HARDWARE REQUIREMENTS :**

- Transformer (12V)
- IC-555 timer
- CD4026 (Decade counter /7-segment decoder)
- CD4011 NAND gate
- Diodes
- Capacitors
- Resisters
- LEDs
- Photodiode
- 7-segment Display
- Buzzer

## Circuit Diagram :

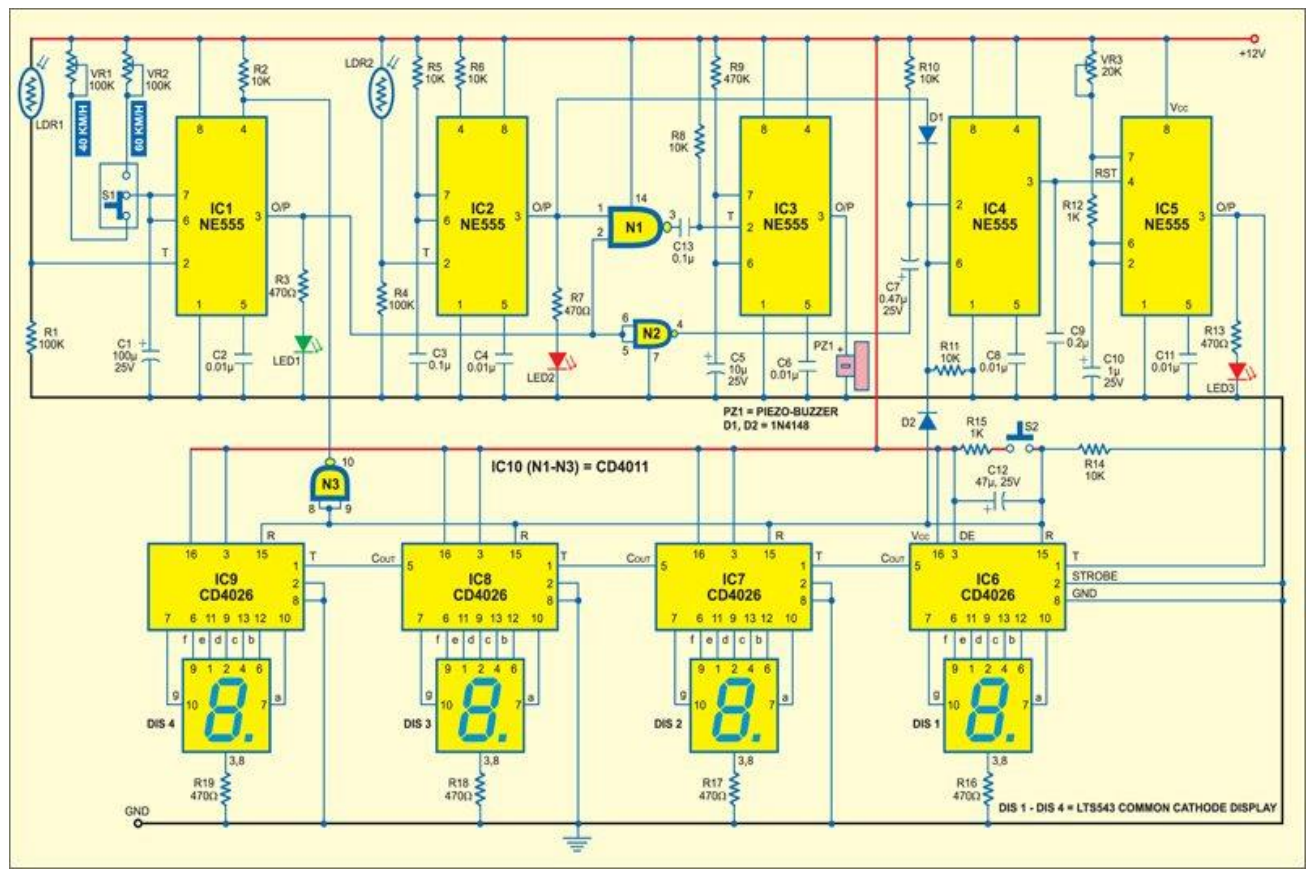

Figure above shows the circuit of the speed checker. It has been designed assuming that the maximum permissible speed for highways is either 40 kmph or 60 kmph as per the traffic rule.

The circuit is built around five NE555 timer ICs (IC1 through IC5), four CD4026 counter ICs (IC6 through IC9) and four 7-segment displays (DIS1 through DIS4).

IC1 through IC3 function as monostables, with IC1 serving as count-start mono, IC2 as count-stop mono and IC3 as speed-limit detector mono,

controlled by IC1 and IC2 outputs. Bistable set-reset IC4 is also controlled by the outputs of IC1 and IC2 and it (IC4), in turn, controls switching on/off of the 100Hz (period = 0.01 second) astable timer IC5.

## **Circuit description :**

The time period of timer NE555 (IC1) count-start monostable multivibrator is adjusted using preset VR1 or VR2 and capacitor C1.

For 40kmph limit the time period is set for 9 seconds using preset VR1, while for 60kmph limit the time period is set for 6 seconds using preset VR2.

Slide switch S1 is used to select the time period as per the speed limit (40 kmph and 60 kmph, respectively).

The junction of LDR1 and resistor R1 is coupled to pin 2 of IC1.

Normally, light from the laser keeps falling on the LDR sensor continuously and thus the LDR offers a low resistance and pin 2 of IC1 is high.

Whenever light falling on the LDR is interrupted by any vehicle, the LDR resistance goes high and hence pin 2 of IC1 goes low to trigger the monostable.

As a result, output pin 3 goes high for the preset period (9 or 6 seconds) and LED1 glows to indicate it.

The time period of timer NE555 (IC1) count-start monostable multivibrator is adjusted using preset VR1 or VR2 and capacitor C1.

Reset pin 4 is controlled by the output of NAND gate N3 at power-on or whenever reset switch S2 is pushed.

For IC2, the monostable is triggered in the same way as IC1 when the vehicle intersects the laser beam incident on LDR2 to generate a small pulse for stopping the count and for use in the speed detection.

LED2 glows for the duration for which pin 3 of IC2 is high.

The outputs of IC1 and IC2 are fed to input pins 2 and 1 of NAND gate N1, respectively. When the outputs of IC1 and IC2 go high simultaneously (meaning that the vehicle has crossed the preset speed limit),

output pin 3 of gate N1 goes low to trigger monostable timer IC3. The output of IC3 is used for driving piezobuzzer PZ1,

which alerts the operator of speed-limit violation. Resistor R9 and capacitor C5 decide the time period for which the piezobuzzer sounds.

## **Circuit operation :**

The output of IC1 triggers the bistable (IC4) through gate N2 at the leading edge of the count-start pulse. When pin 2 of IC4 goes low, the high output at its pin 3 enables astable clock generator IC5. Since the count-stop pulse output of IC2 is connected to pin 6 of IC4 via diode D1, it resets clock generator IC5. IC5 can also be reset via diode D2 at power-on as well as when reset switch S2 is pressed.

IC5 is configured as an astable multivibrator whose time period is decided by preset VR3, resistor R12 and capacitor C10.

Using preset VR1, the frequency of the astable multivibrator is set as 100 Hz. The output of IC5 is fed to clock pin 1 of decade counter/7-segment decoder IC6 CD4026.

## **Formula :**

the system comprises two laser transmitters- LDR sensor pairs, which are installed on the highway 100 meters apart, with the transmitter and the LDR sensor of each pair on the opposite sides of the road. The installation of lasers and LDRs is shown in fig 3 below. The system displays the time taken by the vehicle in crossing this 100m distance from one pair to the other with a resolution of 0.01 second from which the speed of the vehicle can be calculated as follows:

$$\begin{aligned} \text{Speed (km/h)} &= \text{Distance/Time} \\ &= 0.1 \text{ km} * 3600 / (\text{Reading} * 0.01) \end{aligned}$$

Or,

$$\text{Reading on display} = 3600 / \text{Speed.}$$

As per the above equation for a speed of 40 kmph the display will read 900 (or 9 second), and for a speed 60 kmph the display will read 600 (or 6 seconds).

Note that the LSB of the display equals 0.01 second and each succeeding digit is ten times the preceding digit. You can similarly calculate the other readings (or time).



**This whole process goes under following steps:**

Step 1- Apply the power supply by flipping the switch to ON.

Step 2- Reset the circuit so that display shows '0000'.

Step 3- Select the speed limit to 60 kmph.

Step 4- When any vehicle crosses the first IR Diode light, PHOTO DIODE1 will trigger IC1 hence LED 1 glow during for period.

Step 5- When the vehicle crosses the second IR Diode light, the output of IC2 goes high and LED2 glows for this period.

Step 6- If the vehicle crosses the distance between the IR Diode set-ups at more than 60 kmph, the piezo-buzzer sounds an alarm.

Step 7- The counter starts counting when the first IR Diode beam is intercepted and stops when the second IR Diode beam is intercepted.

Step 8- The time taken by the vehicle to cross both the IR Diode beams is displayed on the 7-segment display.

## **NE 555 TIMER :**

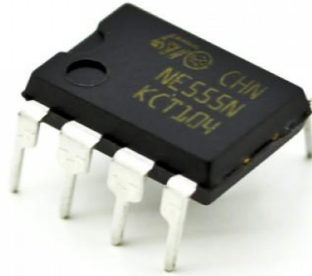

NE 555 TIMER

### **1. Introduction:**

The 555 timer IC was introduced in the year 1970 by Signetic Corporation and gave the name **SE/NE 555 timer**. It is basically a monolithic timing circuit that produces accurate and highly stable time delays or oscillation. When compared to the applications of an op-amp in the same areas, the 555IC is also equally reliable and is cheap in cost. Apart from its applications as a monostable multivibrator and astable multivibrator, a 555 timer can also be used in dc-dc converters, digital logic probes, waveform generators, analog frequency meters and tachometers, temperature measurement and control devices, voltage regulators etc. The timer IC is setup to work in either of the two modes – one-shot or monostable or as a free-running or astable multivibrator. The **SE 555** can be used for temperature ranges between  $-55^{\circ}\text{C}$  to  $125^{\circ}$ . The **NE 555** can be used for a temperature range between  $0^{\circ}$  to  $70^{\circ}\text{C}$ .

### **The important features of the 555 timer are:**

- It operates from a wide range of power supplies ranging from + 5 Volts to + 18 Volts supply voltage.
- Sinking or sourcing 200 mA of load current.

- The external components should be selected properly so that the timing intervals can be made into several minutes along with the frequencies exceeding several hundred kilo hertz.
- The output of a 555 timer can drive a transistor-transistor logic (TTL) due to its high current output.
- It has a temperature stability of 50 parts per million (ppm) per degree Celsius change in temperature, or equivalently 0.005 %/°C.
- The duty cycle of the timer is adjustable.
- The maximum power dissipation per package is 600 mW and its trigger and reset inputs have logic compatibility. More features are listed in the datasheet.

## 2. IC Pin Configuration:

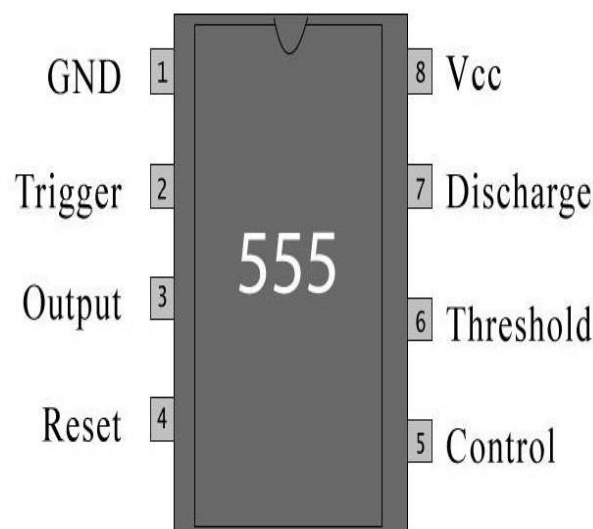

IC 555 PIN CONFIGURATION

The 555 Timer IC is available as an 8-pin metal can, an 8-pin mini DIP (dual-in-package) or a 14-pin DIP. The pin configuration is shown in the figures.

This IC consists of 23 transistors, 2 diodes and 16 [resistors](#). The use of each pin in the IC is explained below. The pin numbers used below

refers to the 8-pin DIP and 8-pin metal can packages. These pins are explained in detail, and you will get a better idea after going through the entire post.

**Pin 1: Grounded Terminal:** All the voltages are measured with respect to the Ground terminal.

**Pin 2: Trigger Terminal:** The trigger pin is used to feed the trigger input when the 555 IC is set up as a monostable multivibrator. This pin is an inverting input of a [comparator](#) and is responsible for the transition of **flip-flop** from set to reset. The output of the timer depends on the amplitude of the external trigger pulse applied to this pin. A negative pulse with a dc level greater than  $V_{CC}/3$  is applied to this terminal. In the negative edge, as the trigger passes through  $V_{CC}/3$ , the output of the lower comparator becomes high and the complementary of Q becomes zero. Thus the 555 IC output gets a high voltage, and thus a quasi stable state.

**Pin 3: Output Terminal:** Output of the timer is available at this pin. There are two ways in which a load can be connected to the output terminal. One way is to connect between output pin (pin 3) and ground pin (pin 1) or between pin 3 and supply pin (pin 8). The load connected between output and ground supply pin is called the *normally on load* and that connected between output and ground pin is called the *normally off load*.

**Pin 4: Reset Terminal:** Whenever the timer IC is to be reset or disabled, a negative pulse is applied to pin 4, and thus is named as reset terminal. The output is reset irrespective of the input condition. When this pin is not to be used for reset purpose, it should be connected to  $+V_{CC}$  to avoid any possibility of false triggering.

**Pin 5: Control Voltage Terminal:** The threshold and trigger levels are controlled using this pin. The pulse width of the output waveform is determined by connecting a POT or bringing in an external voltage to this pin. The external voltage applied to this pin can also be used to modulate the output waveform. Thus, the amount of voltage applied in this terminal will decide when the comparator is to be switched, and thus changes the pulse width of the output. When this

pin is not used, it should be bypassed to ground through a 0.01 micro Farad to avoid any noise problem.

**Pin 6: Threshold Terminal:** This is the non-inverting input terminal of comparator 1, which compares the voltage applied to the terminal with a reference voltage of  $2/3 V_{CC}$ . The amplitude of voltage applied to this terminal is responsible for the set state of flip-flop. When the voltage applied in this terminal is greater than  $2/3V_{CC}$ , the upper comparator switches to  $+V_{sat}$  and the output gets reset.

**Pin 7: Discharge Terminal:** This pin is connected internally to the collector of transistor and mostly a capacitor is connected between this terminal and ground. It is called discharge terminal because when transistor saturates, capacitor discharges through the transistor. When the transistor is cut-off, the capacitor charges at a rate determined by the external resistor and capacitor.

**Pin 8: Supply Terminal:** A supply voltage of + 5 V to + 18 V is applied to this terminal with respect to ground (pin 1).

## 2. The Monostable 555 Timer:

Monostable Multivibrator is also known as One Shot Multivibrator. As its name indicates it has one stable state and it switches to unstable state for a predetermined time period  $T$  when it is triggered. The time period  $T$  is determined by the RC time constant in the circuit. Monostable mode of 555 Timer is commonly used for generating Pulse Width Modulated (PWM) waves.

The 8<sup>th</sup> pin and 1<sup>st</sup> pin of the 555 timer are used to give power  $V_{CC}$  and Ground respectively. 4<sup>th</sup> pin is the Reset pin of 555 Timer, which is active low so it is connected to  $V_{CC}$  to avoid accidental resets. 5<sup>th</sup> pin is the Control Voltage pin used to provide external reference voltage to internal comparators. Since it is not used here, it is grounded via a capacitor  $C'$  ( $0.01\mu F$ ) to avoid high frequency noises. When a negative trigger is applied on the Trigger input of 555, output goes high and capacitor starts charging through resistor  $R$ . When the

capacitor voltage becomes greater than  $2/3 V_{cc}$ , output goes low and capacitor starts discharging through the Discharge pin of 555 Timer.

#### **4. Bistable 555 Timer :**

When an astable multivibrator has no stable states and a monostable multivibrator has a single stable state, a device with two absolute stable states is possible. A Bistable multivibrator is a type of circuit which has two stable states (high and low). It stays in the same state until and unless an external trigger input is applied.

Generally, a bistable multivibrator stays low until a trigger signal is applied and it stays high until a reset signal is applied. Bistable multivibrators are also called as flip-flops or latches. The term flip-flop is used because it 'flips' to one state and stays there until a trigger is applied and once the trigger is applied it 'flops' back to the original state.

#### **5. Working Principle:**

Refer Pin Diagram of 555 timer IC given above:

The internal resistors act as a voltage divider network, providing  $(2/3)V_{cc}$  at the non-inverting terminal of the upper comparator and  $(1/3)V_{cc}$  at the inverting terminal of the lower comparator. In most applications, the control input is not used, so that the control voltage equals  $(2/3)V_{cc}$ . Upper comparator has a threshold input (pin 6) and a control input (pin 5). Output of the upper comparator is applied to set (S) input of the flip-flop. Whenever the threshold voltage exceeds the control voltage, the upper comparator will set the flip-flop and its output is high. A high output from the flip-flop when given to the base of the discharge transistor saturates it and thus discharges the transistor that is connected externally to the discharge pin 7. The complementary signal out of the flip-flop goes to pin 3, the output.

The output available at pin 3 is low. These conditions will prevail until lower comparator triggers the flip-flop. Even if the voltage at the threshold input falls below  $(2/3) V_{CC}$ , that is upper comparator cannot cause the flip-flop to change again. It means that the upper comparator can only force the flip-flop's output high.

To change the output of flip-flop to low, the voltage at the trigger input must fall below  $(1/3) V_{CC}$ . When this occurs, lower comparator triggers the flip-flop, forcing its output low. The low output from the flip-flop turns the discharge transistor off and forces the power amplifier to output a high. These conditions will continue independent of the voltage on the trigger input. Lower comparator can only cause the flip-flop to output low.

From the above discussion it is concluded that for the having low output from the timer 555, the voltage on the threshold input must exceed the control voltage or  $(2/3) V_{CC}$ . This also turns the discharge transistor on. To force the output from the timer high, the voltage on the trigger input must drop below  $(1/3) V_{CC}$ . This turns the discharge transistor off.

A voltage may be applied to the control input to change the levels at which the switching occurs. When not in use, a 0.01 nano Farad capacitor should be connected between pin 5 and ground to prevent noise coupled onto this pin from causing false triggering.

Connecting the reset (pin 4) to a logic low will place a high on the output of flip-flop. The discharge transistor will go on and the power amplifier will output a low. This condition will continue until reset is taken high. This allows synchronization or resetting of the circuit's operation. When not in use, reset should be tied to  $+V_{CC}$ .

## IC- CD4026 :

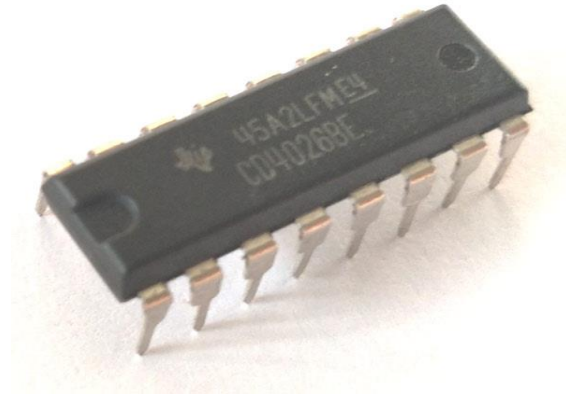

IC-CD4026

### 1. Introduction

CD4026 is a **Johnson counter IC** commonly used in digital display. It has a 5 stage Johnson decade counter with a decoder which converts the Johnson code to a 7 segment decoded output. To put it simply, it will convert the input into numeric display and can be seen on [7 segment display](#) or with LED. It can be used for displaying analogue value such as temperature with [pic microcontroller](#) or for counting objects. There are various other applications like in 7 segment decimal display circuit, in clocks, timer etc.

### 2. Features

- Counter for 7-Segment display
- Can drive a common cathode 7-Segment display directly
- Easy to interface with timer or micron rollers (TTL compatible)
- Can be easily cascaded with more IC to display higher range of number
- Maximum Clock Frequency: 6Mhz
- Available in 16-pin PDIP, GDIP, PDSO packages



### 3. IC Pin Configuration

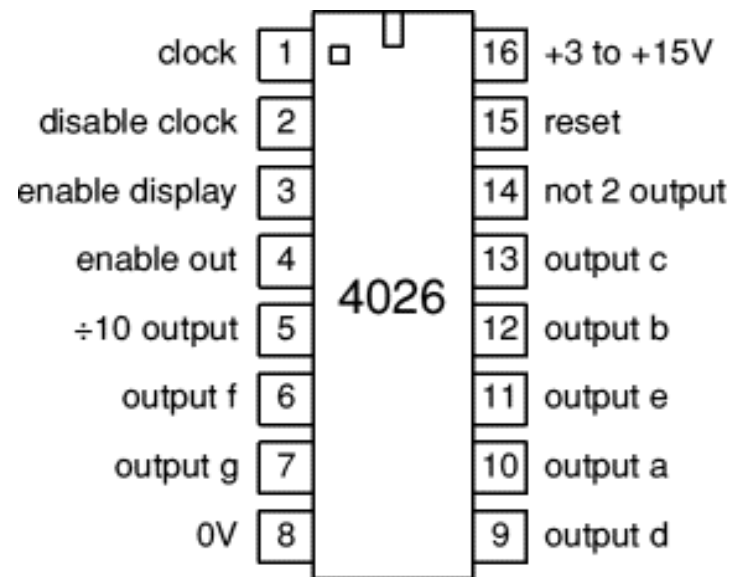

4026 PIN CONFIGURATION

## IC-CD4011



IC CD4011

## 1. Introduction :

CD4011 is the most commonly used complementary metal oxide Semiconductor (CMOS) chip. The IC comprises of 14 pins with four independent NAND gates (N1,N2,N3,N3) in a single chip. Each NAND gate has two inputs and one output. The working of cd4011 IC requires 5V to 16V to operate. Each output can deliver output current of about 10mA at 12V but this range can reduce as the power supply voltage reduces. The positive terminal of the battery was connected to the pin 14 and negative terminal of the battery was connected to the pin 7. The output pins of the IC are 3,4,10,11 and input pins are 1,2,5,6,9,8,12,13. Now let us see how this Integrated circuit works and how can we use it for our operations.

## 2. IC Pin Configuration:

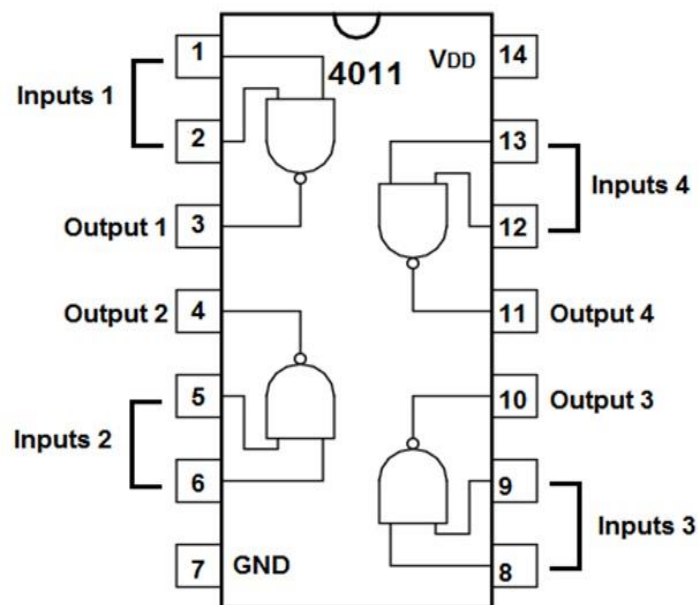

DIAGRAM OF IC 4011

### 3. Working Principle:

The operation of this IC was very simple to understand if we understand the operations of NAND gates. As you can see in the above diagram the NAND gates N1...N4 was wired independently and there is no dependency on other gates. So the operation of the IC was completely based on the NAND gate property. We can see the state of the output pins with the assigned inputs in the truth table given above. There we can see that the NAND gate gives a high output to all the input states except the input states 1,1. The combined action of these four gates form the working of this IC CD4011.

You may have a question that why can't we use single NAND gates instead of this IC since it has the same function as NAND gate. Let me tell you why, usage of large range of the NAND gates occupies more space and also it withdraws more power arising problems in power management to a circuit. This IC was used since it withdraws only small power and also reduces the complexity of the circuit.

## 7-SEGMENT DISPLAY :

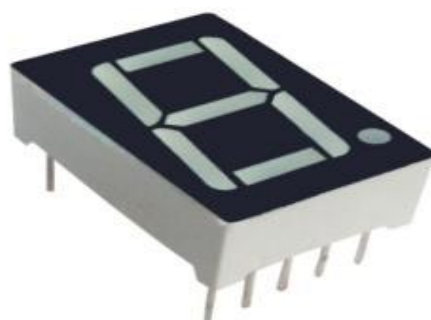

### 1. Introduction:

A seven-segment display (SSD), or seven-segment indicator, is a form of electronic display device for displaying decimal numerals that is an alternative to the more complex dot-matrix displays. Seven-segment

displays are widely used in digital clocks, electronic meters, and other electronic devices for displaying numerical information. A seven segment display, as its name indicates, is composed of seven elements. Individually on or off, they can be combined to produce simplified representations of the Arabic numerals. The seven segments are arranged as a rectangle of two vertical segments on each side with one horizontal segment on the top, middle, and bottom. Additionally, the seventh segment bisects the rectangle horizontally. There are also fourteen-segment displays and sixteen-segment displays (for full alphanumeric).

## 2. IC Pin Configuration:

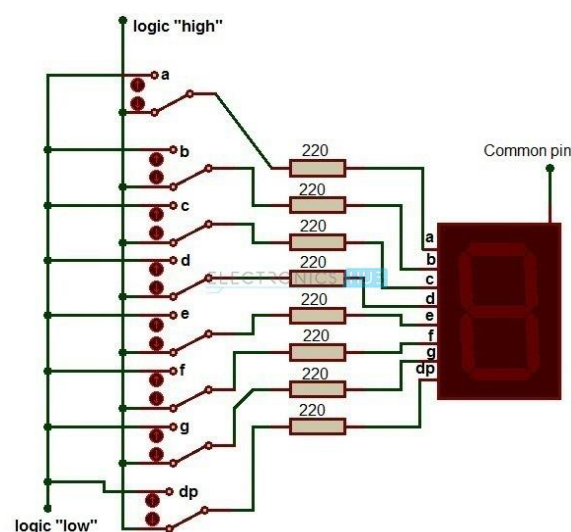

7-SEGMENT DISPLAY PIN DIAGRAM

## 3. Working Principle:

The circuit is pretty straight forward connect the common cathode's to gnd with a 330 ohm current limiting resistor. Connect the seven segment displays pin number 7(A) to arduino pin2 , 6(B) to arduino pin3 , 4 (C) to arduino pin 4 , 2 (D) to arduino pin5 , 1 (E) to arduino pin6 , 9 (F) to arduino pin7 , 10 (G) to arduino pin8 , 5 (DP) to

arduino pin9. For the 2nd project first make the multiplexing circuit below and then follow these connections pattern. Segment A to pin 7, Segment B to pin 8, Segment C to pin 4, Segment D to pin 3, Segment E to pin 2, Segment F to pin 6, Segment G to pin 5, Gnd1 via resistor to pin 11, Gnd2 via resistor to pin 9.

## **BUZZER :**



BUZZER

### **1. Introduction:**

An electric signaling device that makes a buzzing sound.

### **2. Types:**

#### **Electromechanical**

Early devices were based on an electromechanical system identical to an electric bell without the metal gong. Similarly, a relay may be connected to interrupt its own actuating current, causing the contacts to buzz. Often these units were anchored to a wall or ceiling to use it as a sounding board. The word "buzzer" comes from the rasping noise that electromechanical buzzers made.

## **Mechanical**

A joy buzzer is an example of a purely mechanical buzzer and they require drivers. Other examples of them are doorbells.

## **Piezoelectric**

A piezoelectric element may be driven by an oscillating electronic circuit or other audio signal source, driven with a piezoelectric audio amplifier. Sounds commonly used to indicate that a button has been pressed are a click, a ring or a beep.

## **APPLICATIONS :**

It will maintain the safety of human life on the road.

It can also be used on the bridge for the control of speed.

This system can also be used inside university campus areas or inside any company's premises or any crowded area.

## **Conclusion :**

Here we implemented the “speed checker on highway “from point of view of safety on the Mega Highway.

We feel that if mega highway is supported with such faithful system then will not only help to maintain the traffic rules but also reduces accidents.

As system is compact & user friendly one man can handle the system efficiently.

