

HOME AUTOMATION USING ARDUINO

by

Name	Roll No.	Registration No:
ANIRBAN BHOWMIK	11700314015	141170110197 of 2014-2015
SANDIP KUMAR DAS	11700314080	141170110262 of 2014-2015
SOUVIK ACHARYA	11700314107	141170110289 of 2014-2015
TUSHARKANTI MURMU	11700315146	151170120047 of 2015-2016

A comprehensive project report has been submitted in partial fulfillment of the requirements for the degree of

Bachelor of Technology

in

ELECTRONICS & COMMUNICATION ENGINEERING

Under the supervision of

Mrs.Pampa Debnath

Professor



Department of Electronics & Communication Engineering
RCC INSTITUTE OF INFORMATION TECHNOLOGY
Affiliated to Maulana Abul Kalam Azad University of Technology, WestBengal
CANAL SOUTH ROAD, BELIAGHATA, KOLKATA – 700015

May,2018

CERTIFICATE OF APPROVAL



This is to certify that the project titled **HOME AUTOMATION SYSTEM USING ARDUINO** carried out by

Name	Roll No.	Registration No:
ANIRBAN BHOWMIK	11700314015	141170110197 of 2014- 2015
SANDIP KUMAR DAS	11700314080	141170110262 of 2014-2015
SOUVIK ACHARYA	11700314107	141170110289 of 2014-2015
TUSHARKANTI MURMU	11700315146	151170120047 of 2015-2016

for the partial fulfillment of the requirements for B.Tech degree in **Electronics and Communication Engineering** from **Maulana Abul Kalam Azad University of Technology, West Bengal** is absolutely based on his own work under the supervision of **Mrs. Pampa Debnath**. The contents of this thesis, in full or in parts, have not been submitted to any other Institute or University for the award of any degree or diploma.

Optional in case of External Supervisor

.....
Dr./Mr./Ms./Mrs.
Designation and Department
Institute

.....
Dr./Mr./Ms./Mrs.
Professor , Dept. of ECE
RCC Institute of Information Technology

.....
Dr. Abhishek Basu
Head of the Department (ECE)
RCC Institute of Information Technology

DECLARATION



“We Do hereby declare that this submission is our own work conformed to the norms and guidelines given in the Ethical Code of Conduct of the Institute and that, to the best of our knowledge and belief, it contains no material previously written by another neither person nor material (data, theoretical analysis, figures, and text) which has been accepted for the award of any other degree or diploma of the university or other institute of higher learning, except where due acknowledgement has been made in the text.”

.....
Anirban Bhowmik

Registration No:141170110197 OF 2014-2015
Roll No: 11700314015

.....
Sandip Kumar Das

Registration No:141170110262 OF 2014-2015
Roll No:11700314080

.....
Souvik Acharya

Registration No:141170110289 OF 2014-2015
Roll No: 11700314107

.....
Tusharkanti Murmu

Registration No:151170120047 OF 2015-2016
Roll No: 11700315146

Date:

Place:

CERTIFICATE of ACCEPTANCE



This is to certify that the project titled **HOME AUTOMATION SYSTEM USING ARDUINO** carried out by

Name	Roll No.	Registration No:
ANIRBAN BHOWMIK	11700314015	141170110197 of 2014-2015
SANDIP KUMAR DAS	11700314080	141170110262 of 2014-2015
SOUVIK ACHARYA	11700314107	141170110289 of 2014-2015
TUSHARKANTI MURMU	11700315146	151170120047 of 2015-2016

is hereby recommended to be accepted for the partial fulfillment of the requirements for B.Tech degree in **Electronics and Communication Engineering** from **Maulana Abul Kalam Azad University of Technology, West Bengal**

Name of the Examiner Signature with Date

1.

2.....

3.....

4.

ABSTRACT

The main objective of this project is to develop a home automation system using an Arduino board with Bluetooth being remotely controlled by any Android OS smart phone. As technology is advancing so houses are also getting smarter. Modern houses are gradually shifting from conventional switches to centralized control system, involving remote controlled switches. Presently, conventional wall switches located in different parts of the house makes it difficult for the user to go near them to operate. Even more it becomes more difficult for the elderly or physically handicapped people to do so. Remote controlled home automation system provides a most modern solution with smart phones. In order to achieve this, a Bluetooth module is interfaced to the Arduino board at the receiver end while on the transmitter end, a GUI application on the cell phone sends ON/OFF commands to the receiver where loads are connected. By touching the specified location on the GUI, the loads can be turned ON/OFF remotely through this technology. The loads are operated by Arduino board through opto-isolators and thyristors using triacs.

CONTENTS

CERTIFICATE.....	1
DECLARATION.....	2
CERTIFICATE of ACCEPTANCE.....	3
ABSTRACT.....	5
CONTENTS.....	6
LIST OF FIGURES.....	7
INTRODUCTION.....	8
COMPONENTS REQUIRED.....	9
DESCRIPTION.....	10
BLOCK DIAGRAM	40
CIRCUIT DIAGRAM.....	41
CODE.....	42
APPLICATION	45
CONCLUSION.....	48
REFERENCE.....	49

LIST OF FIGURES

FIG 1	ARDUINO UNO R3	PAGE 12
FIG 2	2 CHANNEL RELAY	PAGE 30
FIG 3	2 CHANNEL RELAY	PAGE 33
FIG 4	BLUETOOTH MODULE	PAGE 36
FIG 5	PIN DESCRIPTION OF BLUETOOTH MODULE	PAGE 36
FIG 6	BLOCK DIAGRAM	PAGE 39
FIG 7	CIRCUIT DIAGRAM	PAGE 40

INTRODUCTION

Nowadays, we have remote controls for our television sets and other electronic systems, which have made our lives real easy. Have you ever wondered about home automation which would give the facility of controlling tube lights, fans and other electrical appliances at home using a remote control? Off-course, Yes! But, are the available options cost-effective? If the answer is No, we have found a solution to it. We have come up with a new system called Arduino based home automation using Bluetooth. This system is super-cost effective and can give the user, the ability to control any electronic device without even spending for a remote control. This project helps the user to control all the electronic devices using his/her smartphone. Time is a very valuable thing. Everybody wants to save time as much as they can. New technologies are being introduced to save our time. To save people's time we are introducing Home Automation system using Bluetooth . With the help of this system you can control your home appliances from your mobile phone. You can turn on/off your home appliances within the range of Bluetooth.

COMPONENTS REQUIRED

- 1) ARDUINO UNO
- 2) 2 CHANNEL RELAY(5v)
- 3) BLUETOOTH MODULE HC05
- 4) POWER SUPPLY
- 5) LOAD(BULB 220V)
- 6) CONNECTING WIRES
- 7) VERO BOARD
- 8) SMARTPHONE(BLUETOOTH ENABLED)

DESCRIPTION

ARDUINO UNO

Arduino is an open source computer hardware and software company, project, and user community that designs and manufactures single-board microcontrollers and microcontroller kits for building digital devices and interactive objects that can sense and control objects in the physical and digital world. The project's products are distributed as open-source hardware and software, which are licensed under the GNU Lesser General Public License (LGPL) or the GNU General Public License (GPL), permitting the manufacture of Arduino boards and software distribution by anyone. Arduino boards are available commercially in preassembled form, or as do-it-yourself (DIY) kits.

Arduino board designs use a variety of microprocessors and controllers. The boards are equipped with sets of digital and analog input/output (I/O) pins that may be interfaced to various expansion boards or Breadboards (*shields*) and other circuits. The boards feature serial communications interfaces, including Universal Serial Bus (USB) on some models, which are also used for loading programs from personal computers. The microcontrollers are typically programmed using a dialect of features from the programming languages C and C++. In addition to using traditional compiler toolchains, the Arduino project provides an integrated development environment (IDE) based on the Processing language project.

The Arduino project started in 2003 as a program for students at the Interaction Design Institute Ivrea in Ivrea, Italy, aiming to provide a low-cost and easy way for novices and professionals to create devices that interact with their environment using sensors and actuators. Common examples of such devices intended for beginner hobbyists include simple robots, thermostats, and motion detectors.

The name *Arduino* comes from a bar in Ivrea, Italy, where some of the founders of the project used to meet. The bar was named after Arduin of Ivrea, who was the margrave of the March of Ivrea and King of Italy from 1002 to 1014.

Features of the Arduino UNO:

Microcontroller: ATmega328

Operating Voltage: 5V

Input Voltage (recommended): 7-12V

Input Voltage (limits): 6-20V

Digital I/O Pins: 14 (of which 6 provide PWM output)

Analog Input Pins: 6

DC Current per I/O Pin: 40 mA

DC Current for 3.3V Pin: 50 mA

Flash Memory: 32 KB of which 0.5 KB used by bootloader

SRAM: 2 KB (ATmega328)

EEPROM: 1 KB (ATmega328)

Clock Speed: 16 MHz

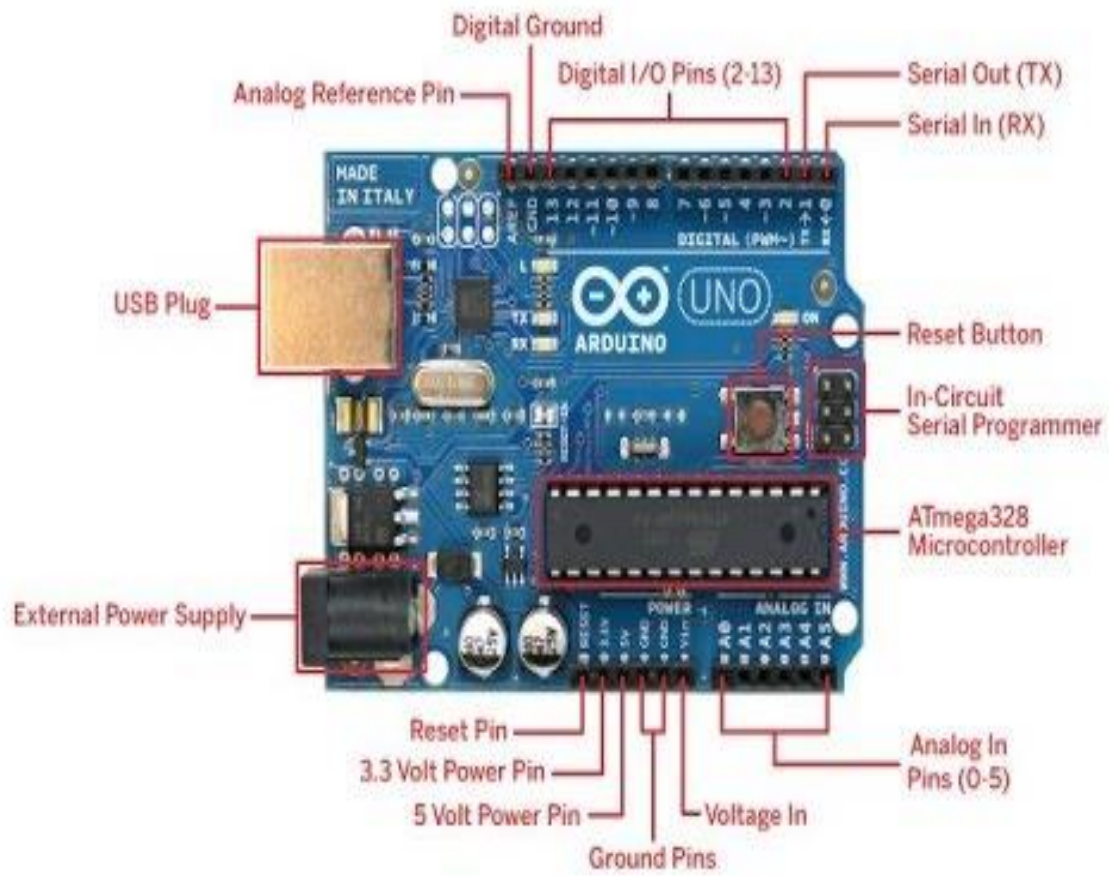

FIG 1 ARDUINO UNO R3

ARDUINO HARDWARE PART:-

Arduino is open-source hardware. The hardware reference designs are distributed under a Creative Commons Attribution Share-Alike 2.5 license and are available on the Arduino website. Layout and production files for some versions of the hardware are also available.

Although the hardware and software designs are freely available under copyleft licenses, the developers have requested the name *Arduino* to be exclusive to the official product and not be used for derived works without permission. The official policy document on use of the Arduino name emphasizes that the project is open to incorporating work by others into the official product. Several Arduino-compatible products commercially released have avoided the project name by using various names ending in *-duino*.

Most Arduino boards consist of an Atmel 8-bit AVR microcontroller (ATmega8, ATmega168, ATmega328, ATmega1280, ATmega2560) with varying amounts of flash memory, pins, and features. The 32-bit Arduino Due, based on the Atmel SAM3X8E was introduced in 2012. The boards use single or double-row pins or female headers that facilitate connections for programming and incorporation into other circuits. These may connect with add-on modules termed *shields*. Multiple and possibly stacked shields may be individually addressable via an I²C serial bus. Most boards include a 5 V linear regulator and a 16 MHz crystal oscillator or ceramic resonator. Some designs, such as the LilyPad, run at 8 MHz and dispense with the onboard voltage regulator due to specific form-factor restrictions.

Arduino microcontrollers are pre-programmed with a boot loader that simplifies uploading of programs to the on-chip flash memory. The default bootloader of the Arduino UNO is the optiboot bootloader. Boards are loaded with program code via a serial connection to another computer. Some serial Arduino boards contain a level shifter circuit to convert between RS-232 logic levels and transistor–transistor logic(TTL) level signals. Current Arduino boards are programmed via Universal Serial Bus (USB), implemented using USB-to-serial adapter chips such as the FTDI FT232. Some boards, such as later-model Uno boards, substitute the FTDI chip with a separate AVR chip containing USB-to-serial firmware, which is reprogrammable via its own ICSP header. Other variants, such as the Arduino Mini and the unofficial Boarduino, use a detachable USB-to-serial adapter board or cable, Bluetooth or other methods. When used with

traditional microcontroller tools, instead of the Arduino IDE, standard AVR in-system programming (ISP) programming is used.

The Arduino board exposes most of the microcontroller's I/O pins for use by other circuits. The *Diecimila*, *Duemilanove*, and current *Uno* provide 14 digital I/O pins, six of which can produce pulse-width modulated signals, and six analog inputs, which can also be used as six digital I/O pins. These pins are on the top of the board, via female 0.1-inch (2.54 mm) headers. Several plug-in application shields are also commercially available. The Arduino Nano, and Arduino-compatible Bare Bones Board and Boarduino boards may provide male header pins on the underside of the board that can plug into solderless breadboards.

Many Arduino-compatible and Arduino-derived boards exist. Some are functionally equivalent to an Arduino and can be used interchangeably. Many enhance the basic Arduino by adding output drivers, often for use in school-level education, to simplify making buggies and small robots. Others are electrically equivalent but change the form factor, sometimes retaining compatibility with shields, sometimes not. Some variants use different processors, of varying compatibility.

ARDUINO SOFTWARE PART:-

IDE

The Arduino integrated development environment (IDE) is a cross-platform application (for Windows, macOS, Linux) that is written in the programming language Java. It originated from the IDE for the languages *Processing* and *Wiring*. It includes a code editor with features such as text cutting and pasting, searching and replacing text, automatic indenting, brace matching, and syntax highlighting, and provides simple *one-click* mechanisms to compile and upload programs to an Arduino board. It also contains a message area, a text console, a toolbar with buttons for common functions and a hierarchy of operation menus. The source code for the IDE is released under the GNU General Public License, version 2.

The Arduino IDE supports the languages C and C++ using special rules of code structuring. The Arduino IDE supplies a software library from the Wiring project, which provides many common input and output procedures. User-written code only requires two basic functions, for starting the sketch and the main program loop, that are compiled and linked with a program stub *main()* into an executable cyclic executive program with the GNU toolchain, also included with the IDE distribution. The Arduino IDE employs the program *avrdude* to convert the executable code into a text file in hexadecimal encoding that is loaded into the Arduino board by a loader program in the board's firmware.

Sketch

A program written with the Arduino IDE is called a *sketch*.^[58] Sketches are saved on the development computer as text files with the file extension *.ino*. Arduino Software (IDE) pre-1.0 saved sketches with the extension *.pde*.

A minimal Arduino C/C++ program consist of only two functions:

setup(): This function is called once when a sketch starts after power-up or reset. It is used to initialize variables, input and output pin modes, and other libraries needed in the sketch.

loop(): After *setup()* has been called, function *loop()* is executed repeatedly in the main program. It controls the board until the board is powered off or is reset.

Blink example

Most Arduino boards contain a light-emitting diode (LED) and a load resistor connected between pin 13 and ground, which is a convenient feature for many tests and program functions. A typical program for a beginning Arduino programmer blinks a LED repeatedly. This program uses the functions *pinMode()*, *digitalWrite()*, and *delay()*, which are provided by the internal libraries included in the IDE environment. This program is usually loaded into a new Arduino board by the manufacturer.

RELAY:

A relay is an electrically operated switch. Many relays use an electromagnet to mechanically operate a switch, but other operating principles are also used, such as solid-state relays. Relays are used where it is necessary to control a circuit by a separate low-power signal, or where several circuits must be controlled by one signal. The first relays were used in long distance telegraph circuits as amplifiers: they repeated the signal coming in from one circuit and re-transmitted it on another circuit. Relays were used extensively in telephone exchanges and early computers to perform logical operations.

A type of relay that can handle the high power required to directly control an electric motor or other loads is called a contactor. Solid-state relays control power circuits with no moving parts, instead using a semiconductor device to perform switching. Relays with calibrated operating characteristics and sometimes multiple operating coils are used to protect electrical circuits from overload or faults; in modern electric power systems these functions are performed by digital instruments still called "protective relays".

Magnetic latching relays require one pulse of coil power to move their contacts in one direction, and another, redirected pulse to move them back. Repeated pulses from the same input have no effect. Magnetic latching relays are useful in applications where interrupted power should not be able to transition the contacts.

Magnetic latching relays can have either single or dual coils. On a single coil device, the relay will operate in one direction when power is applied with one polarity, and will reset when the polarity is reversed. On a dual coil device, when polarized voltage is applied to the reset coil the contacts will transition. AC controlled magnetic latch relays have single coils that employ steering diodes to differentiate between operate and reset commands.

A type of relay that can handle the high power required to directly control an electric motor or other loads is called a contactor. Solid-state relays control power circuits with no moving parts, instead using a semiconductor device to perform switching. Relays with calibrated operating characteristics and sometimes multiple operating coils are used to protect electrical circuits from overload or faults; in modern electric power systems these functions are performed by digital instruments still called "protective relays".

The Arduino Relay module allows a wide range of microcontroller such as Arduino, AVR, PIC, ARM with digital outputs to control larger loads and devices like AC or DC Motors, electromagnets, solenoids, and incandescent light bulbs. This module is designed to be integrated with 2 relays that it is capable of control 2 relays. The relay shield uses one QIANJI JQC-3F high-quality relay with rated load 7A/240VAC, 10A/125VAC, 10A/28VDC. The relay output state is individually indicated by a light-emitting diode.

2 channel relay features:

Number of Relays: 2

Control signal: TTL level

Rated load: 7A/240VAC 10A/125VAC 10A/28VDC

Contact action time: 10ms/5ms

Types:-

1)Coaxial relay

Where radio transmitters and receivers share one antenna, often a coaxial relay is used as a TR (transmit-receive) relay, which switches the antenna from the receiver to the transmitter. This protects the receiver from the high power of the transmitter. Such relays are often used in transceivers which combine transmitter and receiver in one unit. The relay contacts are designed not to reflect any radio frequency power back toward the source, and to provide very high isolation between receiver and transmitter terminals. The characteristic impedance of the relay is matched to the transmission line impedance of the system, for example, 50 ohms.

2)Contactor

A contactor is a heavy-duty relay with higher current ratings, used for switching electric motors and lighting loads. Continuous current ratings for common contactors range from 10 amps to several hundred amps. High-current contacts are made with alloys containing silver. The unavoidable arcing causes the contacts to oxidize; however, silver oxide is still a good conductor. Contactors with overload protection devices are often used to start motors.

3) Force-guided contacts relay

A 'force-guided contacts relay' has relay contacts that are mechanically linked together, so that when the relay coil is energized or de-energized, all of the linked contacts move together. If one set of contacts in the relay becomes immobilized, no other contact of the same relay will be able to move. The function of force-guided contacts is to enable the safety circuit to check the status of the relay. Force-guided contacts are also known as "positive-guided contacts", "captive contacts", "locked contacts", "mechanically linked contacts", or "safety relays".

These safety relays have to follow design rules and manufacturing rules that are defined in one main machinery standard EN 50205 : Relays with forcibly guided (mechanically linked) contacts. These rules for the safety design are the one that are defined in type B standards such as EN 13849-2 as Basic safety principles and Well-trieed safety principles for machinery that applies to all machines.

Force-guided contacts by themselves can not guarantee that all contacts are in the same state, however they do guarantee, subject to no gross mechanical fault, that no contacts are in opposite states. Otherwise, a relay with several normally open (NO) contacts may stick when energised, with some contacts closed and others still slightly open, due to mechanical tolerances. Similarly, a relay with several normally closed (NC) contacts may stick to the unenergised position, so that when energised, the circuit through one set of contacts is broken, with a marginal gap, while the other remains closed. By introducing both NO and NC contacts, or more commonly, changeover contacts, on the same relay, it then becomes possible to guarantee that if any NC contact is closed, all NO contacts are open, and conversely, if any NO contact is closed, all NC contacts are open. It is not possible to reliably ensure that any particular contact is closed, except by potentially intrusive and safety-degrading sensing of its circuit conditions, however in safety systems it is usually the NO state that is most important, and as explained above, this is reliably verifiable by detecting the closure of a contact of opposite sense.

Force-guided contact relays are made with different main contact sets, either NO, NC or changeover, and one or more auxiliary contact sets, often of reduced current or voltage rating, used for the monitoring system. Contacts may be all NO, all NC, changeover, or a mixture of these, for the monitoring contacts, so that the safety system designer can select the correct

configuration for the particular application. Safety relays are used as part of an engineered safety system.

4) Latching relay

A *latching relay* (also called "impulse", "bistable", "keep", or "stay" relays) maintains either contact position indefinitely without power applied to the coil. The advantage is that one coil consumes power only for an instant while the relay is being switched, and the relay contacts retain this setting across a power outage. A latching relay allows remote control of building lighting without the hum that may be produced from a continuously (AC) energized coil.

In one mechanism, two opposing coils with an over-center spring or permanent magnet hold the contacts in position after the coil is de-energized. A pulse to one coil turns the relay on and a pulse to the opposite coil turns the relay off. This type is widely used where control is from simple switches or single-ended outputs of a control system, and such relays are found in avionics and numerous industrial applications.

Another latching type has a remanent core that retains the contacts in the operated position by the remanent magnetism in the core. This type requires a current pulse of opposite polarity to release the contacts. A variation uses a permanent magnet that produces part of the force required to close the contact; the coil supplies sufficient force to move the contact open or closed by aiding or opposing the field of the permanent magnet. A polarity controlled relay needs changeover switches or an H bridge drive circuit to control it. The relay may be less expensive than other types, but this is partly offset by the increased costs in the external circuit.

In another type, a ratchet relay has a ratchet mechanism that holds the contacts closed after the coil is momentarily energized. A second impulse, in the same or a separate coil, releases the contacts. This type may be found in certain cars, for headlamp dipping and other functions where alternating operation on each switch actuation is needed.

A stepping relay is a specialized kind of multi-way latching relay designed for early automatic telephone exchanges.

An earth leakage circuit breaker includes a specialized latching relay.

Very early computers often stored bits in a magnetically latching relay, such as ferreed or the later remreed in the 1ESS switch.

Some early computers used ordinary relays as a kind of latch—they store bits in ordinary wire spring relays or reed relays by feeding an output wire back as an input, resulting in a feedback loop or sequential circuit. Such an electrically latching relay requires continuous power to maintain state, unlike magnetically latching relays or mechanically ratcheting relays.

In computer memories, latching relays and other relays were replaced by delay line memory, which in turn was replaced by a series of ever-faster and ever-smaller memory technologies.

5)Machine tool relay

A machine tool relay is a type standardized for industrial control of machine tools, transfer machines, and other sequential control. They are characterized by a large number of contacts (sometimes extendable in the field) which are easily converted from normally open to normally closed status, easily replaceable coils, and a form factor that allows compactly installing many relays in a control panel. Although such relays once were the backbone of automation in such industries as automobile assembly, the programmable logic controller (PLC) mostly displaced the machine tool relay from sequential control applications.

A relay allows circuits to be switched by electrical equipment: for example, a timer circuit with a relay could switch power at a preset time. For many years relays were the standard method of controlling industrial electronic systems. A number of relays could be used together to carry out complex functions (relay logic). The principle of relay logic is based on relays which energize and de-energize associated contacts. Relay logic is the predecessor of ladder logic, which is commonly used in programmable logic controllers.

6)Mercury relay

A mercury relay is a relay that uses mercury as the switching element. They are used where contact erosion would be a problem for conventional relay contacts. Owing to environmental considerations about significant amount of mercury used and modern alternatives, they are now comparatively uncommon.

7)Mercury-wetted relay

A mercury-wetted reed relay is a form of reed relay in which the contacts are wetted with mercury. Such relays are used to switch low-voltage signals (one volt or less) where the mercury reduces the contact resistance and associated voltage drop, for low-current signals where surface contamination may make for a poor contact, or for high-speed applications where the mercury eliminates contact bounce. Mercury wetted relays are position-sensitive and must be mounted according to the manufacturer's specifications to work properly. Because of the toxicity and expense of liquid mercury, these relays are now rarely used.

The mercury-wetted relay has one particular advantage, in that the contact closure appears to be virtually instantaneous, as the mercury globules on each contact coalesce. The current rise time through the contacts is generally considered to be a few picoseconds, however in a practical circuit it will be limited by the inductance of the contacts and wiring. It was quite common, before the restrictions on the use of mercury, to use a mercury-wetted relay in the laboratory as a convenient means of generating fast rise time pulses, however although the rise time may be picoseconds, the exact timing of the event is, like all other types of relay, subject to considerable jitter, possibly milliseconds, due to mechanical imperfections.

The same coalescence process causes another effect, which is a nuisance in some applications. The contact resistance is not stable immediately after contact closure, and drifts, mostly downwards, for several seconds after closure, the change perhaps being 0.5 ohm.

8)Multi-voltage relays

Multi-voltage relays are devices designed to work for wide voltage ranges such as 24 to 240 VAC and VDC and wide frequency ranges such as 0 to 300 Hz. They are indicated for use in installations that do not have stable supply voltages.

9) Overload protection relay

Electric motors need overcurrent protection to prevent damage from over-loading the motor, or to protect against short circuits in connecting cables or internal faults in the motor windings. The overload sensing devices are a form of heat operated relay where a coil heats a bimetallic strip, or where a solder pot melts, releasing a spring to operate auxiliary contacts. These auxiliary contacts are in series with the coil. If the overload senses excess current in the load, the coil is de-energized.

This thermal protection operates relatively slowly allowing the motor to draw higher starting currents before the protection relay will trip. Where the overload relay is exposed to the same ambient temperature as the motor, a useful though crude compensation for motor ambient temperature is provided.

The other common overload protection system uses an electromagnet coil in series with the motor circuit that directly operates contacts. This is similar to a control relay but requires a rather high fault current to operate the contacts. To prevent short over current spikes from causing nuisance triggering the armature movement is damped with a dashpot. The thermal and magnetic overload detections are typically used together in a motor protection relay.

Electronic overload protection relays measure motor current and can estimate motor winding temperature using a "thermal model" of the motor armature system that can be set to provide more accurate motor protection. Some motor protection relays include temperature detector inputs for direct measurement from a thermocouple or resistance thermometer sensor embedded in the winding.

10)Polarized relay

A polarized relay places the armature between the poles of a permanent magnet to increase sensitivity. Polarized relays were used in middle 20th Century telephone exchanges to detect faint pulses and correct telegraphic distortion.

11)Reed relay

A reed relay is a reed switch enclosed in a solenoid. The switch has a set of contacts inside an evacuated or inert gas-filled glass tube which protects the contacts against atmospheric corrosion; the contacts are made of magnetic material that makes them move under the influence of the field of the enclosing solenoid or an external magnet.

Reed relays can switch faster than larger relays and require very little power from the control circuit. However, they have relatively low switching current and voltage ratings. Though rare, the reeds can become magnetized over time, which makes them stick 'on' even when no current is present; changing the orientation of the reeds with respect to the solenoid's magnetic field can resolve this problem.

Sealed contacts with mercury-wetted contacts have longer operating lives and less contact chatter than any other kind of relay.

12)Safety relays

Safety relays are devices which generally implement safety functions. In the event of a hazard, the task of such a safety function is to use appropriate measures to reduce the existing risk to an acceptable level.

13)Solid-state contactor

A solid-state contactor is a heavy-duty solid state relay, including the necessary heat sink, used where frequent on-off cycles are required, such as with electric heaters, small electric motors, and lighting loads. There are no moving parts to wear out and there is no contact bounce due to vibration. They are activated by AC control signals or DC control signals from programmable logic controllers (PLCs), PCs, transistor-transistor logic (TTL) sources, or other microprocessor and microcontroller controls.

14)Solid-state relay

A solid-state relay (SSR) is a solid state electronic component that provides a function similar to an electromechanical relay but does not have any moving components, increasing long-term reliability. A solid-state relay uses a thyristor, TRIAC or other solid-state switching device, activated by the control signal, to switch the controlled load, instead of a solenoid. An optocoupler (a light-emitting diode (LED) coupled with a photo transistor) can be used to isolate control and controlled circuits.

15)Static relay

A static relay consists of electronic circuitry to emulate all those characteristics which are achieved by moving parts in an electro-magnetic relay.

16)Time delay relay

Timing relays are arranged for an intentional delay in operating their contacts. A very short (a fraction of a second) delay would use a copper disk between the armature and moving blade assembly. Current flowing in the disk maintains magnetic field for a short time, lengthening release time. For a slightly longer (up to a minute) delay, a dashpot is used. A dashpot is a piston filled with fluid that is allowed to escape slowly; both air-filled and oil-filled dashpots are used. The time period can be varied by increasing or decreasing the flow rate. For longer time periods, a mechanical clockwork timer is installed. Relays may be arranged for a fixed timing period, or may be field adjustable, or remotely set from a control panel. Modern microprocessor-based timing relays provide precision timing over a great range.

Some relays are constructed with a kind of "shock absorber" mechanism attached to the armature which prevents immediate, full motion when the coil is either energized or de-energized. This addition gives the relay the property of time-delay actuation. Time-delay relays can be constructed to delay armature motion on coil energization, de-energization, or both.

Time-delay relay contacts must be specified not only as either normally open or normally closed, but whether the delay operates in the direction of closing or in the direction of opening. The following is a description of the four basic types of time-delay relay contacts.

First we have the normally open, timed-closed (NOTC) contact. This type of contact is normally open when the coil is unpowered (de-energized). The contact is closed by the application of power to the relay coil, but only after the coil has been continuously powered for the specified amount of time. In other words, the direction of the contact's motion (either to close or to open) is identical to a regular NO contact, but there is a delay in closing direction. Because the delay occurs in the direction of coil energization, this type of contact is alternatively known as a normally open, on-delay.

17) Vacuum relay

A sensitive relay having its contacts mounted in a highly evacuated glass housing, to permit handling radio-frequency voltages as high as 20,000 volts without flashover between contacts even though contact spacing is but a few hundredths of an inch when open.

Pole and throw[edit]

Since relays are switches, the terminology applied to switches is also applied to relays; a relay switches one or more *poles*, each of whose contacts can be *thrown* by energizing the coil.

Normally open (NO) contacts connect the circuit when the relay is activated; the circuit is disconnected when the relay is inactive. Normally closed (NC) contacts disconnect the circuit when the relay is activated; the circuit is connected when the relay is inactive. All of the contact forms involve combinations of NO and NC connections.

The National Association of Relay Manufacturers and its successor, the Relay and Switch Industry Association define 23 distinct electrical contact forms found in relays and switches.^[23] Of these, the following are commonly encountered:

SPST-NO (Single-Pole Single-Throw, Normally-Open) relays have a single *Form A* contact or *make* contact. These have two terminals which can be connected or disconnected. Including two for the coil, such a relay has four terminals in total.

SPST-NC (Single-Pole Single-Throw, Normally-Closed) relays have a single *Form B* or *break* contact. As with an *SPST-NO* relay, such a relay has four terminals in total.

SPDT (Single-Pole Double-Throw) relays have a single set of *Form C*, *break before make* or *transfer* contacts. That is, a common terminal connects to either of two others, never connecting to both at the same time. Including two for the coil, such a relay has a total of five terminals.

DPST – Double-Pole Single-Throw relays are equivalent to a pair of *SPST* switches or relays actuated by a single coil. Including two for the coil, such a relay has a total of six terminals. The poles may be *Form A* or *Form B* (or one of each; the designations *NO* and *NC* should be used to resolve the ambiguity).

DPDT – Double-Pole Double-Throw relays have two sets of *Form C* contacts. These are equivalent to two *SPDT* switches or relays actuated by a single coil. Such a relay has eight terminals, including the coil

The *S* (*single*) or *D* (*double*) designator for the pole count may be replaced with a number, indicating multiple contacts connected to a single actuator. For example, *4PDT* indicates a four-pole double-throw relay that has 12 switching terminals.

EN 50005 are among applicable standards for relay terminal numbering; a typical EN 50005-compliant *SPDT* relay's terminals would be numbered 11, 12, 14, A1 and A2 for the C, NC, NO, and coil connections, respectively.^[24]

DIN 72552 defines contact numbers in relays for automotive use;

85 = relay coil -

86 = relay coil +

87 = common contact

87a = normally closed contact

87b = normally open contact

APPLICATIONS OF RELAY:-

Relays are used wherever it is necessary to control a high power or high voltage circuit with a low power circuit, especially when galvanic isolation is desirable. The first application of relays was in long telegraph lines, where the weak signal received at an intermediate station could control a contact, regenerating the signal for further transmission. High-voltage or high-current devices can be controlled with small, low voltage wiring and pilots switches. Operators can be isolated from the high voltage circuit. Low power devices such as microprocessors can drive relays to control electrical loads beyond their direct drive capability. In an automobile, a starter relay allows the high current of the cranking motor to be controlled with small wiring and contacts in the ignition key.

Electromechanical switching systems including Strowger and Crossbar telephone exchanges made extensive use of relays in ancillary control circuits. The Relay Automatic Telephone Company also manufactured telephone exchanges based solely on relay switching techniques designed by Gotthilf Ansgarius Betulander. The first public relay based telephone exchange in the UK was installed in Fleetwood on 15 July 1922 and remained in service until 1959.

The use of relays for the logical control of complex switching systems like telephone exchanges was studied by Claude Shannon, who formalized the application of Boolean algebra to relay circuit design in *A Symbolic Analysis of Relay and Switching Circuits*. Relays can perform the basic operations of Boolean combinatorial logic. For example, the boolean AND function is realised by connecting normally open relay contacts in series, the OR function by connecting

normally open contacts in parallel. Inversion of a logical input can be done with a normally closed contact. Relays were used for control of automated systems for machine tools and production lines. The Ladder programming language is often used for designing relay logic networks.

Early electro-mechanical computers such as the ARRA, Harvard Mark II, Zuse Z2, and Zuse Z3 used relays for logic and working registers. However, electronic devices proved faster and easier to use.

Because relays are much more resistant than semiconductors to nuclear radiation, they are widely used in safety-critical logic, such as the control panels of radioactive waste-handling machinery. Electromechanical protective relays are used to detect overload and other faults on electrical lines by opening and closing circuit breakers.

RELAY H152S MODULE

Overview

We can control high voltage electronic devices using relays. A Relay is actually a switch which is electrically operated by an electromagnet. The electromagnet is activated with a low voltage, for example 5 volts from a microcontroller and it pulls a contact to make or break a high voltage circuit.

FIG 2: 2 CHANNEL RELAY

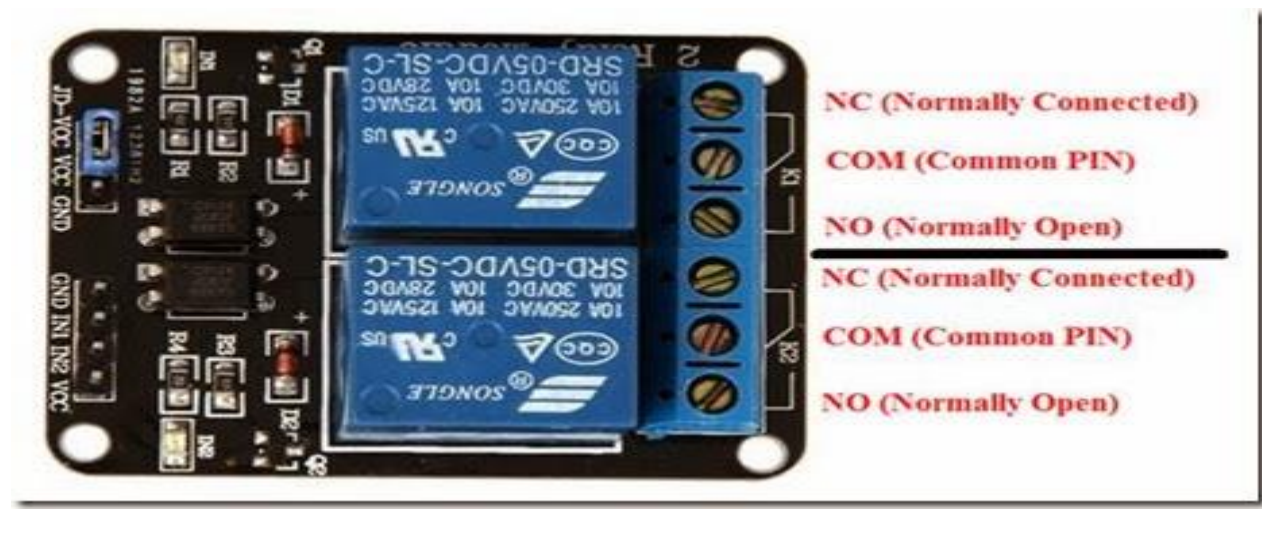

As an example for this Arduino Relay Tutorial we will use the HL-52S 2 channel relay module, which has 2 relays with rating of 10A @ 250 and 125 V AC and 10A @ 30 and 28 V DC. The high voltage output connector has 3 pins, the middle one is the common pin and as we can see from the markings one of the two other pins is for normally open connection and the other one for normally closed connection.

On the other side of the module we have these 2 sets of pins. The first one has 4 pins, a Ground and a VCC pin for powering the module and 2 input pins In1 and In2. The second set of pins has 3 pins with a jumper between the JDVcc and the Vcc pin. With a configuration like this the electromagnet of the relay is directly powered from the Arduino Board and if something goes wrong with the relay the microcontroller could get damaged.

Circuit Schematic

For better understanding let's see the circuit schematics of the relay module in this configuration. So we can see that the 5 volts from our microcontroller connected to the Vcc pin for activating the relay through the Optocoupler IC are also connected to the JDVcc pin which powers the electromagnet of the relay. So in this case we got no isolation between the relay and the microcontroller.

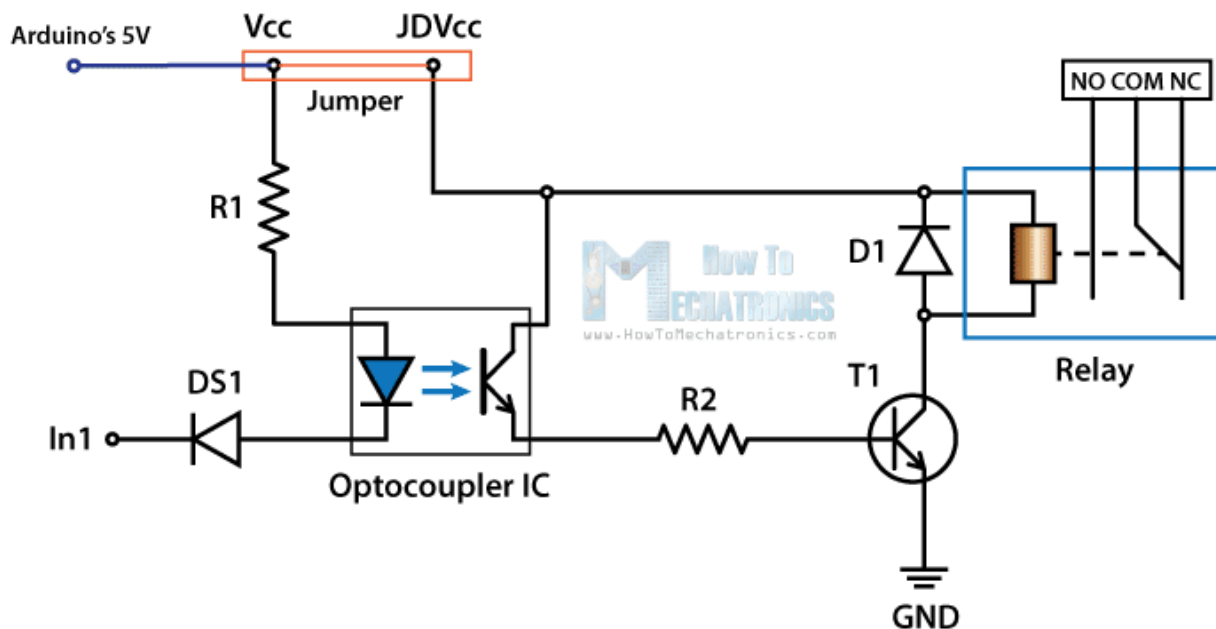

In order to isolate the microcontroller from the relay, we need to remove the jumper and connect separate power supply for the electromagnet to the JDVcc and the Ground pin. Now with this configuration the microcontroller doesn't have any physical connection with the relay, it just uses the LED light of the Optocoupler IC to activate the relay.

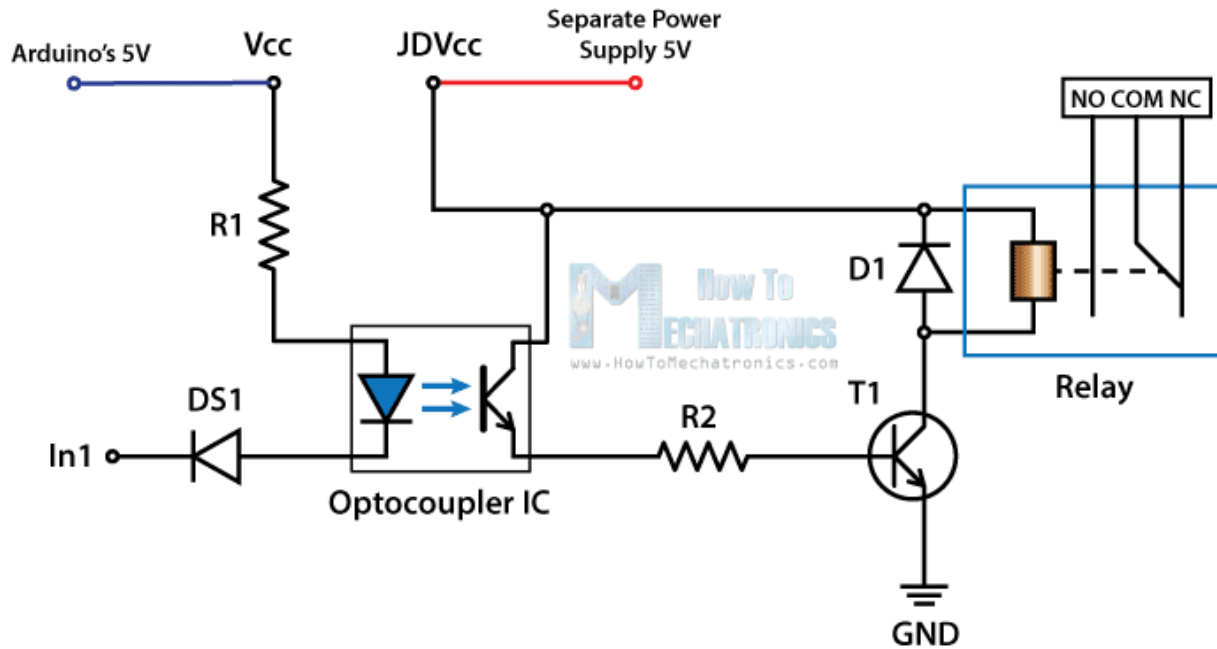

There is one more thing to be noticed from this circuit schematics. The input pins of the module work inversely. As we can see the relay will be activated when the input pin will be LOW because in that way the current will be able to flow from the VCC to the input pin which is low or ground, and the LED will light up and active the relay. When the input pin will be HIGH there will be no current flow, so the LED will not light up and the relay will not be activated.

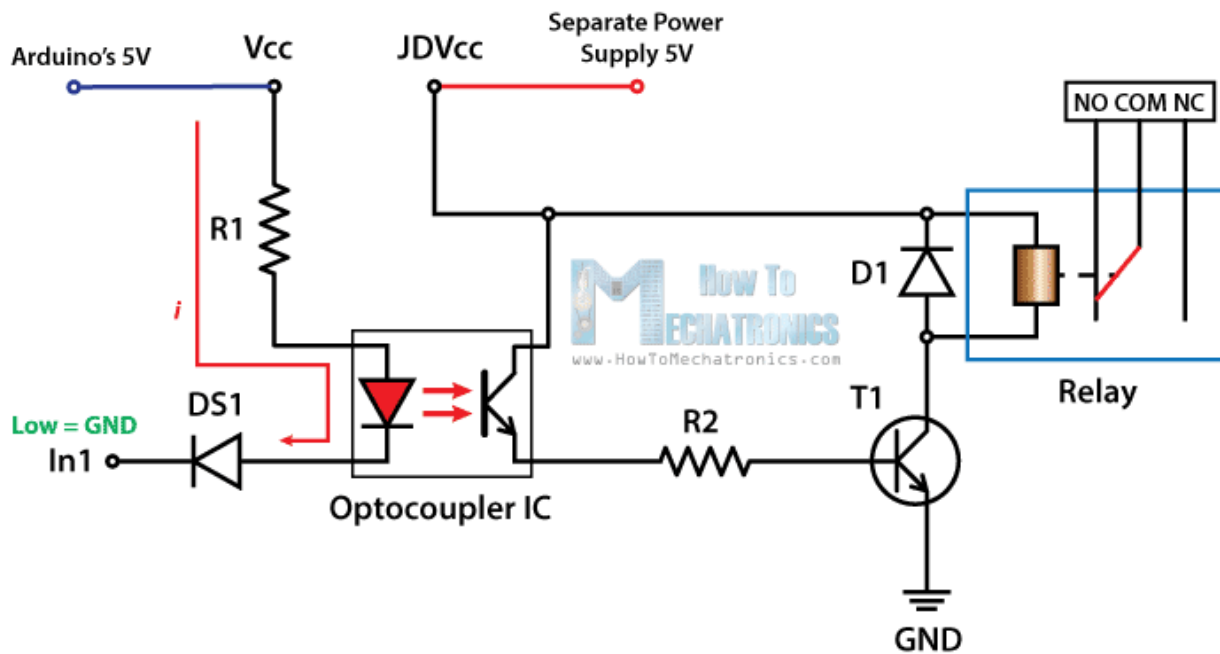

First let's take a look at the circuit diagram. As previously described we will use a 5V Adapter as a separate power supply for the electromagnet connected to the JDVcc and the Ground pin. The Arduino's 5V pin will be connected to the Vcc pin of the module and the pin number 7 to the In1 input pin for controlling the relay. Now for the HIGH Voltage part we need a power plug, a socket and a cable with two wires. One of the two wires will be cut and connected to the common and the normally open pin of the module output connector. So with this configuration when we will activate the relay we will get the high voltage circuit closed and working.

Here's how made the cable. So I bought a plug, a socket and a cable. Then I carefully cut the cable and cut one of the wires as shown in the picture below and connect them to the normally open connection pins of the relay module. Also connected the ends of the cable to the plug and the socket.



FIG 3:2 CHANNEL RELAY

BLUETOOTH MODULE(HC-05 Bluetooth Module)

HC-05 Specification:

Bluetooth protocol: Bluetooth Specification v2.0+EDR

Frequency: 2.4GHz ISM band

Modulation: GFSK(Gaussian Frequency Shift Keying)

Emission power: ≤ 4 dBm, Class 2

Sensitivity: ≤ -84 dBm at 0.1% BER

Speed: Asynchronous: 2.1Mbps(Max) / 160 kbps, Synchronous: 1Mbps/1Mbps

Security: Authentication and encryption

Profiles: Bluetooth serial port

Power supply: +3.3VDC 50mA

Working temperature: -20 ~ +75Centigrade

Dimension: 26.9mm x 13mm x 2.2 mm

Overview

HC-05 module is an easy to use Bluetooth SPP (Serial Port Protocol) module, designed for transparent wireless serial connection setup. The HC-05 Bluetooth Module can be used in a Master or Slave configuration, making it a great solution for wireless communication. This serial port bluetooth module is fully qualified Bluetooth V2.0+EDR (Enhanced Data Rate) 3Mbps Modulation with complete 2.4GHz radio transceiver and baseband. It uses CSR Bluecore 04- External single chip Bluetooth system with CMOS technology and with AFH (Adaptive Frequency Hopping Feature).

Bluetooth Module HC-05

The Bluetooth module HC-05 is a MASTER/SLAVE module. By default the factory setting is SLAVE. The Role of the module (Master or Slave) can be configured only by AT COMMANDS. The slave modules cannot initiate a connection to another Bluetooth device, but can accept connections. Master module can initiate a connection to other devices. The user can use it simply for a serial port replacement to establish connection between MCU and GPS, PC to your embedded project, etc.



FIG 4:BLUETOOTH MODULE

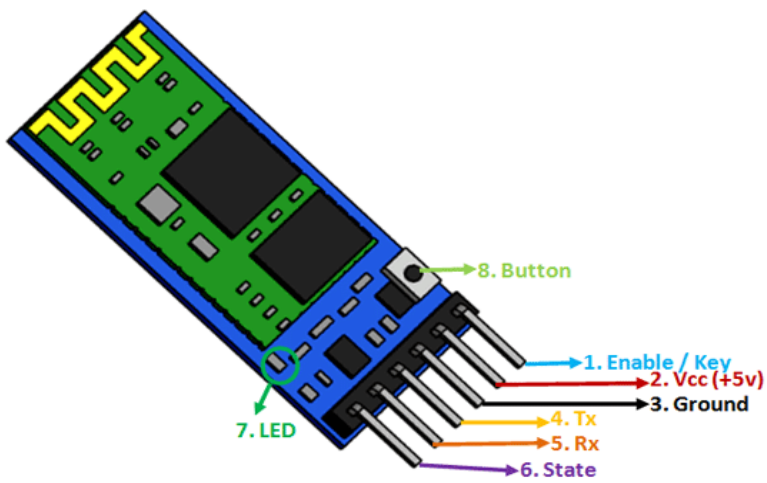

FIG 5 :PIN DESCRIPTION OF BLUETOOTH MODULE

Pin Description:-

The HC-05 Bluetooth Module has 6 pins. They are as follows:

ENABLE:

When enable is pulled LOW, the module is disabled which means the module will not turn on and it fails to communicate. When enable is left open or connected to 3.3V, the module is enabled i.e the module remains on and communication also takes place.

V_{CC}:

Supply Voltage 3.3V to 5V

GND:

Ground pin

TXD & RXD:

These two pins act as a UART interface for communication

STATE:

It acts as a status indicator. When the module is not connected to or paired with any other bluetooth device, signal goes Low. At this low state, the led flashes continuously which denotes that the module is not paired with other device. When this module is connected to/paired with any other bluetooth device, the signal goes High. At this high state, the led blinks with a constant delay say for example 2s delay which indicates that the module is paired.

BUTTON SWITCH:

This is used to switch the module into AT command mode. To enable AT command mode, press the button switch for a second. With the help of AT commands, the user can change the parameters of this module but only when the module is not paired with any other BT device. If

the module is connected to any other bluetooth device, it starts to communicate with that device and fails to work in AT command mode.

HC-05 Default Settings:-

Default Bluetooth Name: "HC-05"

Default Password: 1234 or 0000

Default Communication: Slave

Default Mode: Data Mode

Data Mode Baud Rate: 9600, 8, N, 1

Command Mode Baud Rate: 38400, 8, N, 1

Default firmware: LINVOR

BLOCK DIAGRAM

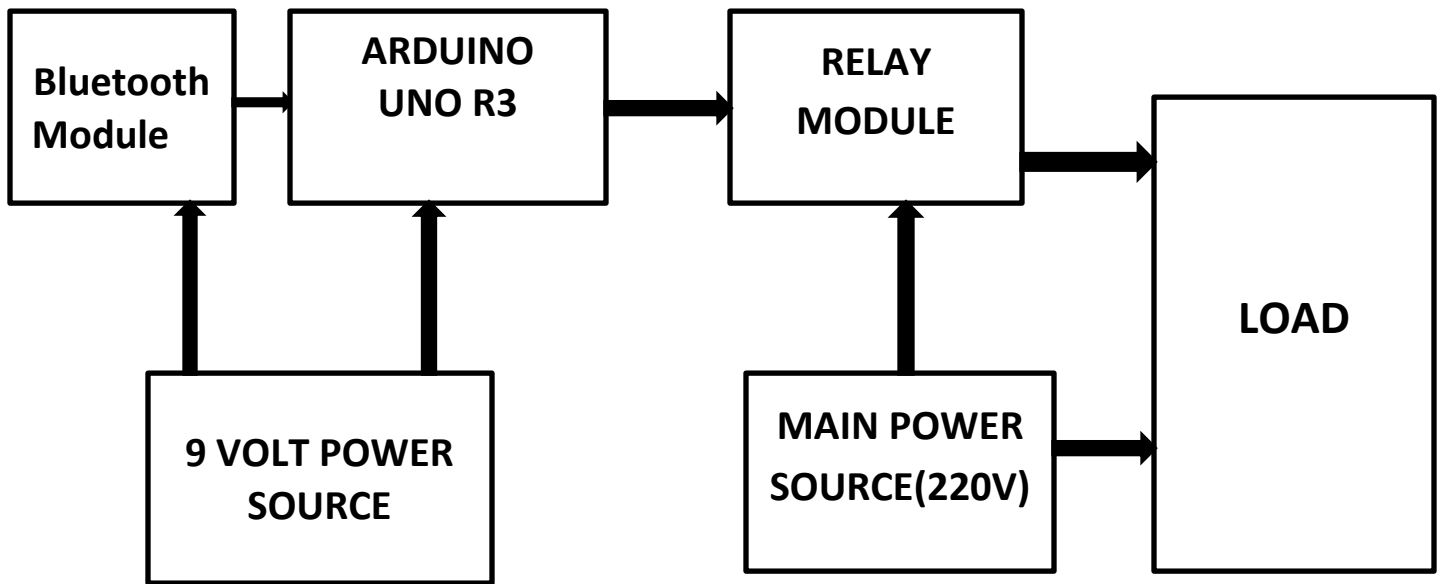

FIG 6:BLOCK DIAGRAM OF HOME AUTOMATION SYSTEM USING ARDUINO AND BLUETOOTH MODULE

CIRCUIT DIAGRAM

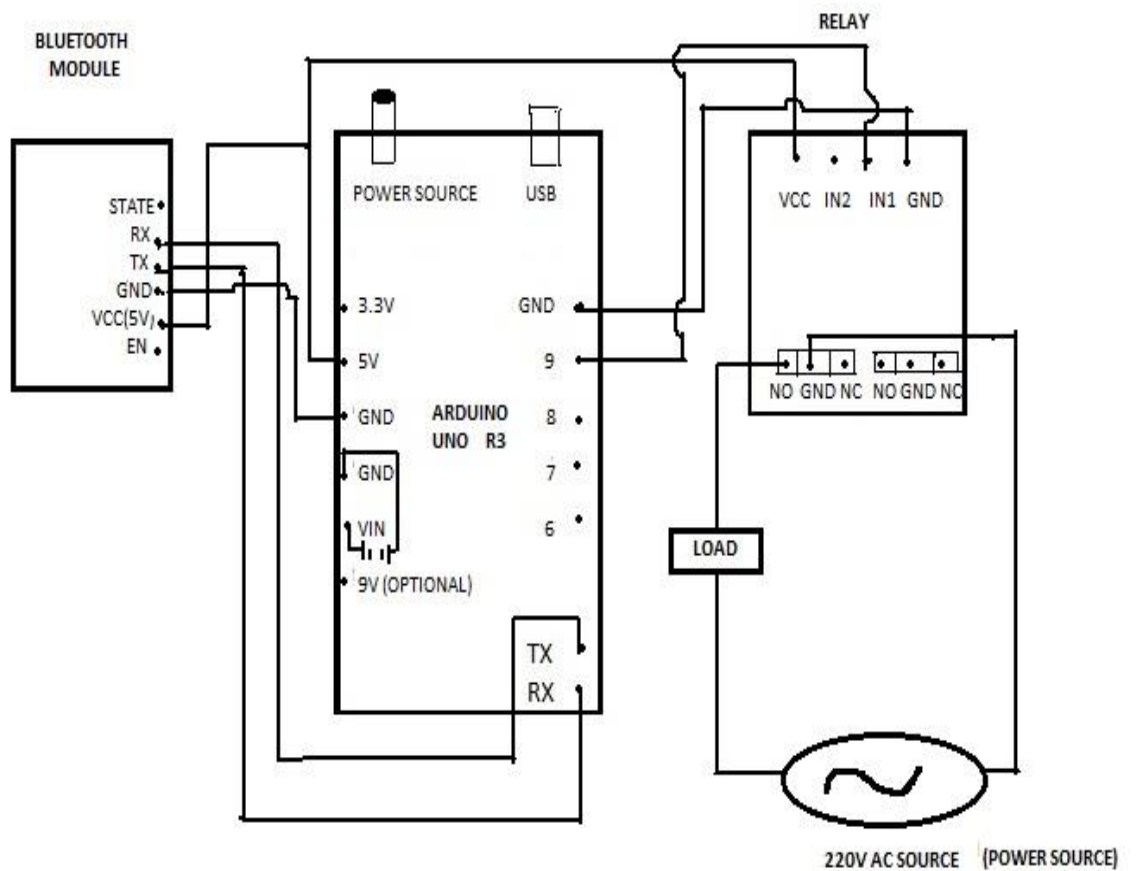

FIG 7:CIRCUIT DIAGRAM OF HOME AUTOMATION SYSTEM USING ARDUINO AND BLUETOOTH MODULE

CODE

CODE :-

```
String inputs;
#define relay1 2 //Connect relay1 to pin 9
#define relay2 3 //Connect relay2 to pin 8
#define relay3 4 //Connect relay3 to pin 7
#define relay4 5 //Connect relay4 to pin 6
#define relay5 6 //Connect relay5 to pin 5
#define relay6 7 //Connect relay6 to pin 4
#define relay7 8 //Connect relay7 to pin 3
#define relay8 9 //Connect relay8 to pin 2
void setup()
{
  Serial.begin(9600); //Set rate for communicating with phone
  pinMode(relay1, OUTPUT); //Set relay1 as an output
  pinMode(relay2, OUTPUT); //Set relay2 as an output
  pinMode(relay3, OUTPUT); //Set relay1 as an output
  pinMode(relay4, OUTPUT); //Set relay2 as an output
  pinMode(relay5, OUTPUT); //Set relay1 as an output
  pinMode(relay6, OUTPUT); //Set relay2 as an output
  pinMode(relay7, OUTPUT); //Set relay1 as an output
  pinMode(relay8, OUTPUT); //Set relay2 as an output
  digitalWrite(relay1, LOW); //Switch relay1 off
  digitalWrite(relay2, LOW); //Swtich relay2 off
  digitalWrite(relay3, LOW); //Switch relay1 off
  digitalWrite(relay4, LOW); //Swtich relay2 off
  digitalWrite(relay5, LOW); //Switch relay1 off
  digitalWrite(relay6, LOW); //Swtich relay2 off
  digitalWrite(relay7, LOW); //Switch relay1 off
  digitalWrite(relay8, LOW); //Swtich relay2 off
}
void loop()
{
  while(Serial.available()) //Check if there are available bytes to read
  {
```

```

delay(10); //Delay to make it stable
char c = Serial.read(); //Conduct a serial read
if (c == '#'){
break; //Stop the loop once # is detected after a word
}
inputs += c; //Means inputs = inputs + c
}
if (inputs.length() >0)
{
Serial.println(inputs);

if(inputs == "A")
{
digitalWrite(relay1, LOW);
}
else if(inputs == "a")
{
digitalWrite(relay1, HIGH);
}
else if(inputs == "B")
{
digitalWrite(relay2, LOW);
}
else if(inputs == "b")
{
digitalWrite(relay2, HIGH);
}
else if(inputs == "C")
{
digitalWrite(relay3, LOW);
}
else if(inputs == "c")
{
digitalWrite(relay3, HIGH);
}
else if(inputs == "D")
{
digitalWrite(relay4, LOW);
}
else if(inputs == "d")
{
digitalWrite(relay4, HIGH);
}
}

```

```
else if(inputs == "E")
{
digitalWrite(relay5, LOW);
}
else if(inputs == "e")
{
digitalWrite(relay5, HIGH);
}
else if(inputs == "F")
{
digitalWrite(relay6, LOW);
}
else if(inputs == "f")
{
digitalWrite(relay6, HIGH);
}
else if(inputs == "G")
{
digitalWrite(relay7, LOW);
}
else if(inputs == "g")
{
digitalWrite(relay7, HIGH);
}
else if(inputs == "H")
{
digitalWrite(relay8, LOW);
}
else if(inputs == "h")
{
digitalWrite(relay8, HIGH);
}
inputs="";
}
}
```

APPLICATIONS

Home Is Where the Smart Is

Even machine-to-machine communication, and you understand you're not the most tech-savvy consumer, it's impossible that you've missed the abundance of home automation products filling the shelves and ads of every home improvement store. Suddenly an ordinary errand for light bulbs will leave you wondering if your lamp could send you a message alerting you that the light bulb needs to be replaced. Furthermore, if your lamp is talking to you, could your refrigerator and sprinkler system be too? Experts say: Yes, the possibilities are endless. If that's the case, where do you begin?

Any day-to-day, repeatable process is automatable with smart home applications. The greater the control and flexibility of these processes, the more energy and cost savings the resident experiences, which are factors anyone who pays utilities strives to moderate. The smart home revolution is likely to be more of an evolution, with the incorporation of one or two home systems at a time, gradually automating our households through smart mobile devices. However, with these elements of efficiency comes the question of ease of use. Will it bring you enjoyment or exasperation? With so many brands and models already available in an ever-growing market, how do you know which is best for you?

Lighting Control: Leaving the Dark Ages and Stepping Into the Light

Smart lighting allows you to control wall switches, blinds, and lamps, but how intuitive is a lighting control system? It turns out, quite; its capabilities are extensive. You're able to schedule the times lights should turn on and off, decide which specific rooms should be illuminated at certain times, select the level of light which should be emitted, and choose how particular lights react through motion sensitivity, as seen with Belkin's WeMo Switch + Motion, which is both affordable and easy to use with its plug-and-play simplicity.

HVAC Regulation: No Longer Burned by Your Heating Bill

As fuel costs rise and the availability and sustainability of our resources becomes a greater concern, heating/cooling our homes efficiently is less a budgetary bonus and more of a necessity. Over the past year, smart thermostats and automated home heating systems have become more readily available and easily incorporate into any home. Heating and cooling our

homes consumes an average of 50% of energy costs yearly, making daily HVAC regulation progressively rewarding. Maintaining a substantial lead among the nearly non-existent competition, the Nest Learning Thermostat, learns your heating and cooling preferences over time, eliminating the need for programming and is accessible from your smartphone app. With automated HVAC you are able to reduce the heat when a room is unoccupied, and increase or decrease it at specific times based on your schedule and occupancy.

Lawn Irrigation Systems: The Grass is Always Greener

A lush and healthy lawn is a source of pride for most homeowners, but the weather doesn't always cooperate and provide the adequate elements for a flourishing landscape. For decades we've relied on sprinkler systems to keep our yards at peak presentation, but at what cost? The average American home spends approximately 30% of their daily water usage on lawn and garden maintenance. Nearly half of that amount is wasted due to inefficiency. If you apply that statistic to the national average, up to 4.5 billion gallons of water is wasted per day through ineffective watering methods. If we reflect upon the monetary impact of this, it results in Americans spending over a thousand dollars a year in water, with a portion of that being waste. The global effects are even greater when you consider the growing concern over climate change and the dramatic decrease in agricultural natural resources. However, sprinkler control systems, like Skydrop, are providing water regulation through real-time communication with local weather data. If a rainstorm develops and deposits two inches of rainwater on your lawn, the automated sprinkler detects the saturation and disables its scheduled watering. Conversely, the system will be alerted to dry conditions and supply the necessary amount of nourishment, without over-watering.

Smart Appliances: What's for Dinner?

Will smart kitchen appliances actually make you a better cook? Maybe. Smart refrigerators, such as LG's Smart ThinQ, allow you to scan grocery store receipts and keep an inventory of your items, and alerts you if an item is about to expire. More impressively, it suggests recipes based on your refrigerator's contents and lets you know when you need to replace items. Smart ovens synch with your smartphone and automatically preheat to the correct temperature based on a recipe selected from your database. While these appliance options seem a bit superficial and convenience based, there is a conservation factor as well. By automating your kitchen appliance and making them accessible from your smart device, you're able to sever the electricity supplied to unused appliances and reduce your energy consumption and costs. Considering the number of appliances the average household owns; this could save a substantial amount of money over time.

Security Systems: Knock, Knock...

Who's there? The Internet of Things. While efficiency and conservation are certainly IoT benefits, its potential to have improved control over home security is a primary focus. Smart locks, like Kwikset's Kevo, a Bluetooth enabled electronic deadbolt, and various connected home security systems, such as iSmartAlarm, offer a variety of features including door and window sensors, motion detectors, video cameras and recording mechanisms. All of which are connected to a mobile device and accessible via the cloud, thus enabling you to access real-time information on the security status of your home. Naturally, there is a great deal of scrutiny regarding the level of trust in controlling your home's security system via a mobile device, but it begs earnest exploration when weighing the potential benefits and peace of mind it provides homeowners.

CONCLUSION

The system as the name indicates, 'Home automation' makes the system more flexible and provides attractive user interface compared to other home automation systems. In this system we integrate mobile devices into home automation systems. A novel architecture for a home automation system is proposed using the relatively new communication technologies. The system consists of mainly three components is a BLUETOOTH module, Arduino microcontroller and relay circuits. WIFI is used as the communication channel between android phone and the Arduino microcontroller. We hide the complexity of the notions involved in the home automation system by including them into a simple, but comprehensive set of related concepts. This simplification is needed to fit as much of the functionality on the limited space offered by a mobile device's display. This paper proposes a low cost, secure, ubiquitously accessible, auto-configurable, remotely controlled solution. The approach discussed in the paper is novel and has achieved the target to control home appliances remotely using the WiFi technology to connects system parts, satisfying user needs and requirements. WiFi technology capable solution has proved to be controlled remotely, provide home security and is cost-effective as compared to the previously existing systems. Hence we can conclude that the required goals and objectives of home automation system have been achieved. The system design and architecture were discussed, and prototype presents the basic level of home appliance control and remote monitoring has been implemented. Finally, the proposed system is better from the scalability and flexibility point of view than the commercially available home automation systems.

REFERENCE

1.Wikipedia

2. Wireless Sensor Networks: Concepts, Applications, Experimentation and Analysis. 2016. p. 108. ISBN 9811004129. The use of standardized, with open standards over proprietary protocols provides the industry with the freedom to choose between suppliers with guaranteed interoperability. Standardized solutions usually have a much longer lifespan than proprietary solutions.

3.Jump up^ "Research and Markets: Global Home Automation and Control Market 2014-2020 - Lighting Control, Security & Access Control, HVAC Control Analysis of the \$5.77 Billion Industry". Reuters. 2015-01-19. Archived from the original on 2016-05-05.

4. Home Automation & Wiring (1 ed.). New York: McGraw-Hill/TAB Electronics. 1999-03-31. ISBN 9780070246744.