

# **VOLTAGE DOUBLER CIRCUIT WITH 555 TIMER**

*A Project report submitted in partial fulfilment  
of the requirements for the degree of B. Tech in Electrical Engineering*

*By*

**ASHFAQUE ARSHAD (11701614014)  
AKSHAY KUMAR (11701614005)  
DEBAYAN MANNA (11701614019)  
SURESH SAHU (11701614056)**

*Under the supervision of*

**MR. SUBHASIS BANERJEE  
Assistant Professor, Electrical Engineering, RCCIIT**



*Department of Electrical Engineering*

**RCC INSTITUTE OF INFORMATION TECHNOLOGY**

CANAL SOUTH ROAD, BELIAGHATA, KOLKATA – 700015, WEST BENGAL

Maulana Abul Kalam Azad University of Technology (MAKAUT)

© 2018

## **ACKNOWLEDGEMENT**

It is my great fortune that I have got opportunity to carry out this project work under the supervision of **(Voltage Doubler Circuit with 555 Timer Circuit under the supervision of Mr. Subhasis Banerjee)** in the Department of Electrical Engineering, RCC Institute of Information Technology (RCCIIT), Canal South Road, Beliaghata, Kolkata-700015, affiliated to Maulana Abul Kalam Azad University of Technology (MAKAUT), West Bengal, India. I express my sincere thanks and deepest sense of gratitude to my guide for his constant support, unparalleled guidance and limitless encouragement.

I wish to convey my gratitude to Prof. (Dr.) Alok Kole, HOD, Department of Electrical Engineering, RCCIIT and to the authority of RCCIIT for providing all kinds of infrastructural facility towards the research work.

I would also like to convey my gratitude to all the faculty members and staffs of the Department of Electrical Engineering, RCCIIT for their whole hearted cooperation to make this work turn into reality.

-----  
**Name and Signature of the Student**

**Place:**  
**Date:**



*Department of Electrical Engineering*  
**RCC INSTITUTE OF INFORMATION TECHNOLOGY**  
GROUND FLOOR, NEW BUILDING,  
CANAL SOUTH ROAD, BELIAGHATA, KOLKATA – 700015, WEST BENGAL

## ***CERTIFICATE***

### **To whom it may concern**

This is to certify that the project work entitled (**Voltage Doubler Circuit with 555 timer**) is the bona fide work carried out by (**Ashfaque Arshad (11701614014), Akshay Kumar (11701614005), Debayan Manna (11701614019), and Suresh Sahu (11701614056)**), a student of B.Tech in the Dept. of Electrical Engineering, RCC Institute of Information Technology (RCCIIT), Canal South Road, Beliaghata, Kolkata-700015, affiliated to Maulana Abul Kalam Azad University of Technology (MAKAUT), West Bengal, India, during the academic year 2017-18, in partial fulfillment of the requirements for the degree of Bachelor of Technology in Electrical Engineering and that this project has not submitted previously for the award of any other degree, diploma and fellowship.

\_\_\_\_\_  
**Signature of the Guide**

**Name:**

**Designation**

\_\_\_\_\_  
**Signature of the HOD**

**Name:**

**Designation**

\_\_\_\_\_  
**Signature of the External Examiner**

**Name:**

**Designation:**

## **: Table of Contents:**

	<u>Page no.</u>
	v
<b>1. Introduction</b>	<b>5</b>
<b>2. Theory</b>	<b>6-9</b>
<b>2.1 Working Principle</b>	<b>10-11</b>
<b>3. Hardware Model</b>	<b>12-13</b>
<b>4. Algorithm and Software Program</b>	<b>14.</b>
<b>5. Observations and Results</b>	<b>15</b>
<b>6. Conclusions</b>	<b>16</b>
<b>Appendix A</b>	<b>25-30</b>
<b>A.1 555 Timer</b>	<b>17-18</b>
<b>A.2 Diode</b>	<b>19-21</b>
<b>A.3 Resistor</b>	<b>22-24</b>
<b>A.4 Capacitor</b>	<b>25-26</b>
<b>A.5 Transformer</b>	<b>27-28</b>
<b>A.6 DC MOTOR</b>	<b>29</b>
<b>A.7 Voltage Regulator</b>	<b>30-32</b>
<b>A.8 Potentiometer</b>	<b>33</b>
<b>A.9 Rectifier</b>	<b>34-37</b>
<b>Application, Advantage</b>	<b>38</b>
<b>Disadvantage</b>	<b>39</b>
<b>References</b>	<b>40</b>

# INTRODUCTION

Usually, power supply system provides 230V AC supply which is being used for different electrical and electronics loads. But, for few loads or electronics equipment like cathode ray tubes, X-ray systems, electrostatic system, laser systems, travelling wave tube etc. requires a high rating power supply for their operation. Thus, the available voltage has to be multiplied using the voltage multipliers circuit. Voltage multiplier is an electrical circuit consisting of capacitors and diodes. It can be used for multiplying or increasing the voltage and also for converting AC supply to DC supply by multiplying voltage and rectifying current.

Different types of voltage multipliers are voltage doubler, voltage tripler, and voltage quadrupler. Apart from this there also some voltage divider.

Mainly, we are going to discuss about voltage doubler circuit diagram and voltage doubler working from voltage multiplier.

**What is a Voltage Doubler?** An electronic voltage multiplier circuit that doubles the voltage by using the charging and the discharging principle of capacitors is called as a voltage doubler. It consists of major electronics components such as capacitors and diodes. The simple voltage doubler circuit consists of two capacitors and two diodes connected as shown in the figure. The voltage doubler circuit can be a simple rectifier which takes an input AC voltage and generates an output DC voltage that is approximately twice the input AC voltage. Even though there are DC to DC voltage doublers, but in these types of voltage doubler circuits driving circuit is required for switching control. There are different types of voltage doubler circuits such as a simple voltage doubler as shown above, voltage doubler using 555 timer, voltage doubler rectifiers like Villard circuit, Greinacher circuit, etc.

## THEORY

A combination of two diodes and capacitors which are appropriately connected in such a way that it doubles the voltage of the supply is one of the simplest form of the voltage multiplier.

An electronic voltage multiplier circuit which take the DC input supply and doubles the voltage by using the charging and discharging principle of capacitors is known as a voltage doubler circuit. It consists of mainly electronics components such as capacitors and diodes.

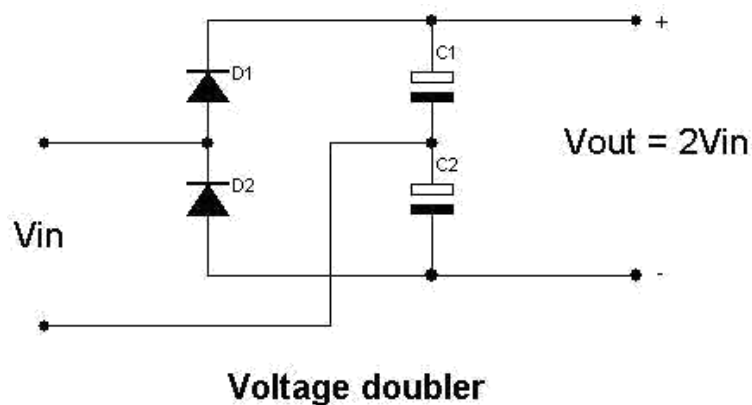

The figure shown above is a simple voltage double circuit which take input as AC supply voltage and rectify it into DC voltage and generate DC output voltage that is approximately twice the AC supply voltage.

There are different types of voltage doubler circuit such as voltage doubler circuit as shown above. There are also voltage doubler circuit which doubles the supply voltage but are in phase opposition.

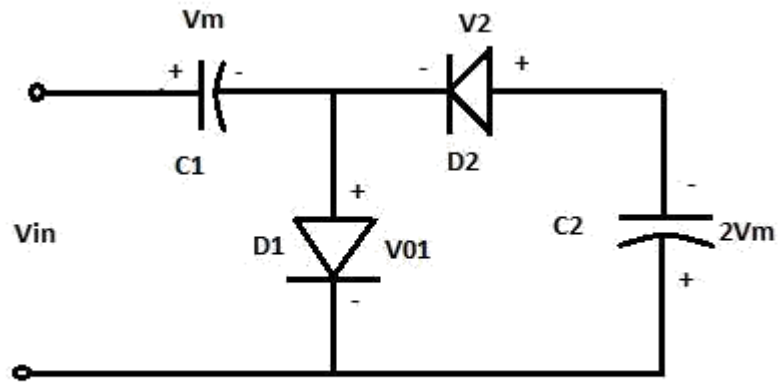

**Figure 2 Voltage doubler circuit with phase opposition**

The figure shown is a voltage doubler circuit which take input AC voltage and generate DC output voltage is appropriately double of the input voltage and are phase opposition of it.

$$V_{01} = V_m - V_m \sin \omega t = V_{D1}$$

$$\text{Also } V_{01} = -V_{D2} - 2V_m$$

$$V_{D2} = -2V_m - V_{01} = -2V_m - (2V_m \sin \omega t - V_m) \\ = -(V_m \sin \omega t + V_m)$$

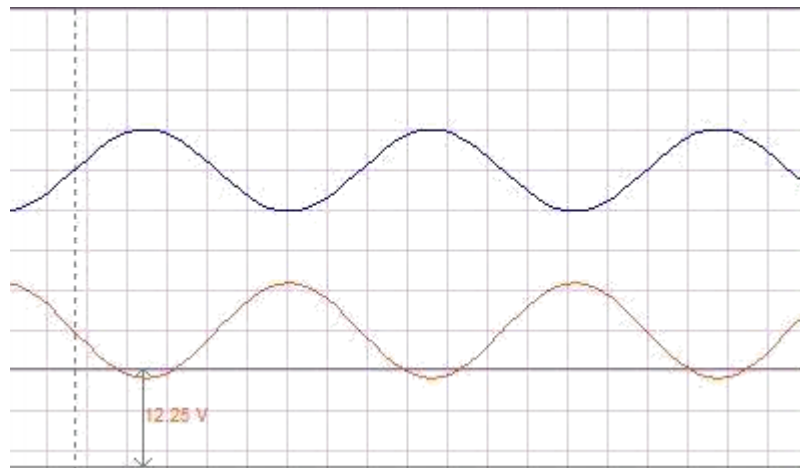

**Figure 3 Waveform of Voltage doubler circuit with phase opposition**

## VOLTAGE DOUBLER CIRCUIT USING 555 TIMER

The voltage doubler circuit using 555 timers is one of the simplest form of voltage multiplier that uses two diodes, five capacitors and 555 timers. The 555 Timer IC yields square waves of 2 KHz frequency with the help of two resistors R<sub>1</sub> and R<sub>2</sub> and one capacitor C<sub>1</sub>. The forward biases diode D<sub>2</sub> and C<sub>3</sub> are connected in series to intensify the signals. The diode D<sub>1</sub> prevents from complete discharge of the capacitor C<sub>3</sub> and capacitor C<sub>4</sub>. It is generally used for protection purposes.

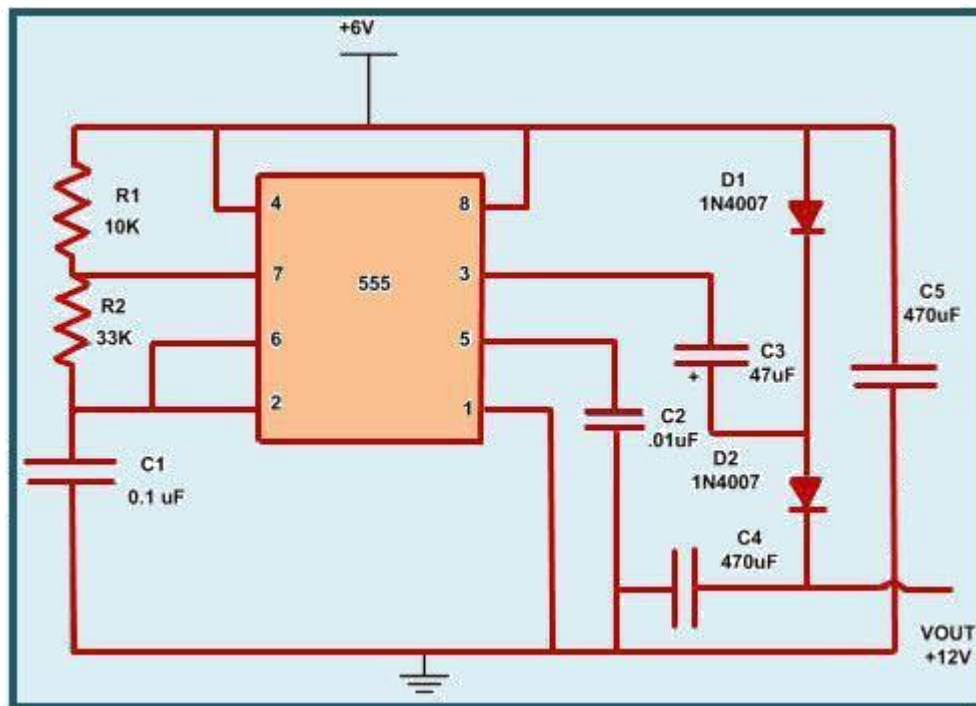

**Figure 4 Doublor Circuit with 555 Timer**

The basic components use in this circuit such capacitors C<sub>3</sub>, C<sub>4</sub> diodes D<sub>1</sub>, D<sub>2</sub> are used for boosting and amplifying the input signal. The circuit components are selected with appropriate ratings. The circuit accepts the input signal voltage ranging from 3V to 12V. If the input voltage exceeds this specified range the components may damage permanently. The diodes used in this circuit are IN4007, if we use diode other than IN4007, then output voltage may decrease due to different breakdown voltage.



Ideally, the figure shown above take the input signal and doubles the signal in its output terminal. If the input voltage is 12V then the output will be 24V, but practically it cannot be possible because of the presence of diodes which allow 0.7V losses for silicon and 0.3V losses for germanium.

### Voltage Multiplier

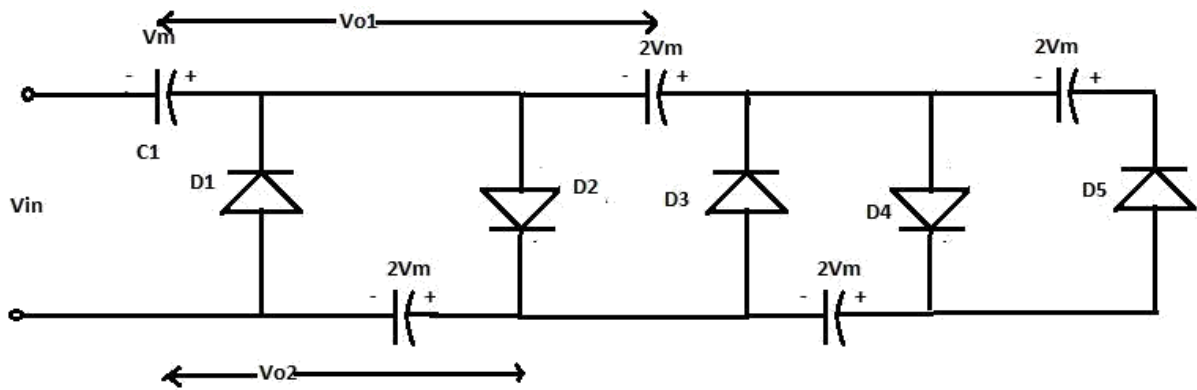

$$V_{01} = V_{03} = V_{05} = V_m \sin \omega t + V_m$$

$$V_{02} = V_{04} = \dots = V_m \sin \omega t - V_m$$

## Working Principle

First we divide the circuit into two parts. First part consists of 555 timer IC operates in astable mode. It generates square wave pulses and second part consist of two diodes and five capacitors for rectifying the signal and then double output voltage. 555 timer IC is operating in astable mode to generate the square wave pulse of approximately 2KHz. The frequency of 555 timer is decided by resistors and capacitors. The formulae of frequency is given as:

$$F=1.44/(R_1+2*R_2) *C_1$$

Where  $R_1$ ,  $R_2$  is the resistor(ohm)

$C_1$  is capacitor(microfarad)

When output of 555 TIMER IC is low, Diode  $D_1$  is forward biased and Capacitor  $C_3$  get charged using the Diode  $D_1$ . Capacitor  $C_3$  get charged up to the supply voltage, which is now 6V. Now when the output at PIN 3 of 555 Timer goes high,  $D_1$  get reversed biased and block the discharge of the capacitor  $C_3$  and at the same time  $D_2$  is forward biased and allow the  $C_4$  to charge. Now the Capacitor  $C_3$  and the input supply voltage, means 6V of capacitor  $C_3$  and 6V of input supply, so it is charges up to 10V (approximately twice the supply voltage).

Value of the supply voltage is change using the potentiometer to 9V. Again the Capacitor  $C_3$  get charged through Diode  $D_1$  but this time to 9V because of change in the supply voltage to 9V. When the output at PIN 3 goes high,  $D_1$  get reversed biased and block the discharge of the capacitor  $C_3$  which is current equal to the supply voltage 9V and at the same time  $D_2$  is forward biased and allow the  $C_4$  to charge. Now the Capacitor  $C_3$  and the input supply voltage, means 9V of capacitor  $C_3$  and 9V of input supply, so it is charges to approximately 17.5V (approximately twice the voltage supply). This continue for

different value of supply voltage which is adjusted by changing the nob of potentiometer.

## **HARDWARE MODEL**

The aim of this project is to develop a circuit which will step up the applied DC voltage using voltage doubler circuit. A 555 timer is used in astable mode to get the output approximately twice the input voltage. The output from the 555 timer is given to a voltage doubler circuit to get the anticipated output.

This system comprises of a voltage doubler circuit which is a combination of five capacitors, two resistors and two diodes. It contains a 555 timer which is running in astable mode. The input voltage applied is about 12 volts DC and the output voltage is about 20 volts DC.

The output of 555 timer passes over a voltage doubler to get around 12V DC with 20% regulation owing to circuit parameters. Thus we get 22V DC approximately.

The load should be limited to less than 5 mA as drawing higher current would result in further poor regulation causing the output voltage falling below the predictable level. The output voltage can be measured with the help of a multi-meter.

Further the project can be improved by adding multiple stages for getting three to six times the input voltage. We are getting 12V AC voltage from the circuit by 230/12V step down transformer. Then we rectify circuit along with a regulator. In the rectifier circuit there are four 1N4007 diodes, one capacitor of 470uF 25V, one capacitor of 1uF (63V) and a 220 ohm resistors. From the rectifier we get the steady DC voltage from variable AC voltage as well as we are getting pulsating DC voltage waveform from sinusoidal AC waveform. Then we can regulate the voltage through 10k potentiometer and 7812.

The voltage doubler using 555 timer circuit and getting the twice of the input voltage in the output. In the circuit we have joined a 555 timer IC, two 1N4007 diodes, a 10k and 33k resistors, 0.1uF, and 0.01uF and three 470uF Capacitors.

For application purpose, we have attached a 300 rpm, 12V DC motor for speed controlling. From this project experiment, we can control speed of motor.

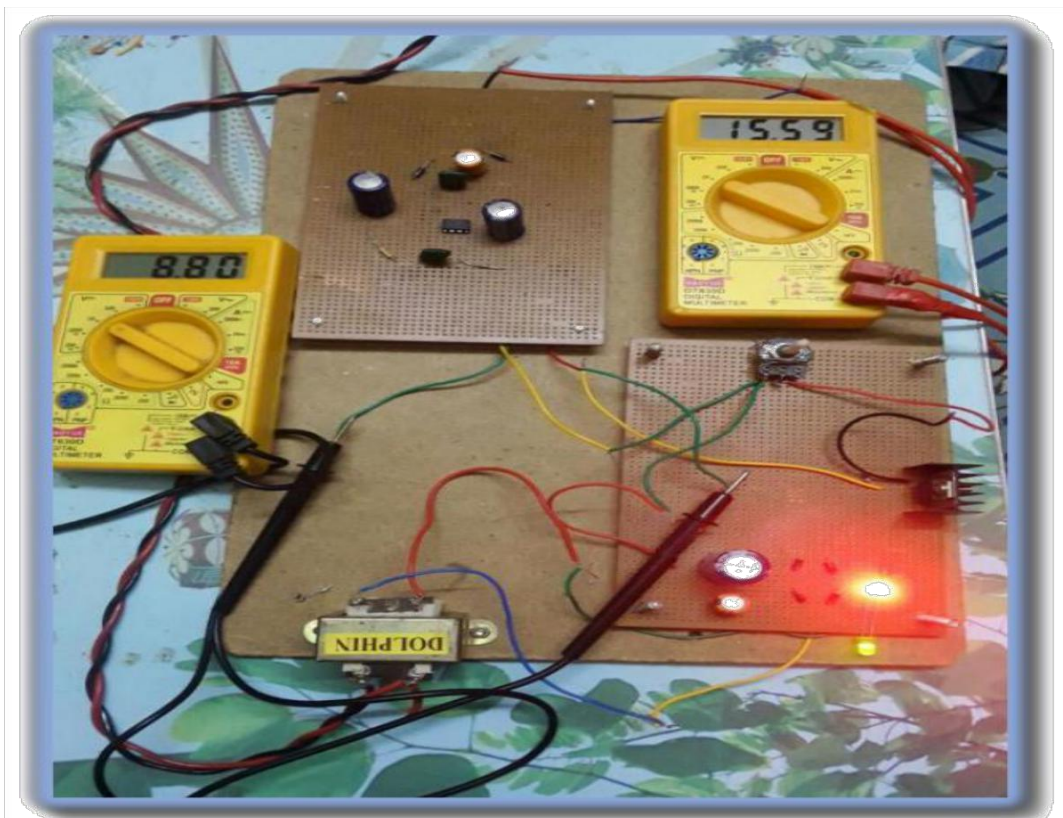

**Hardware model of voltage doubler circuit**

## SOFTWARE PROGRAMME

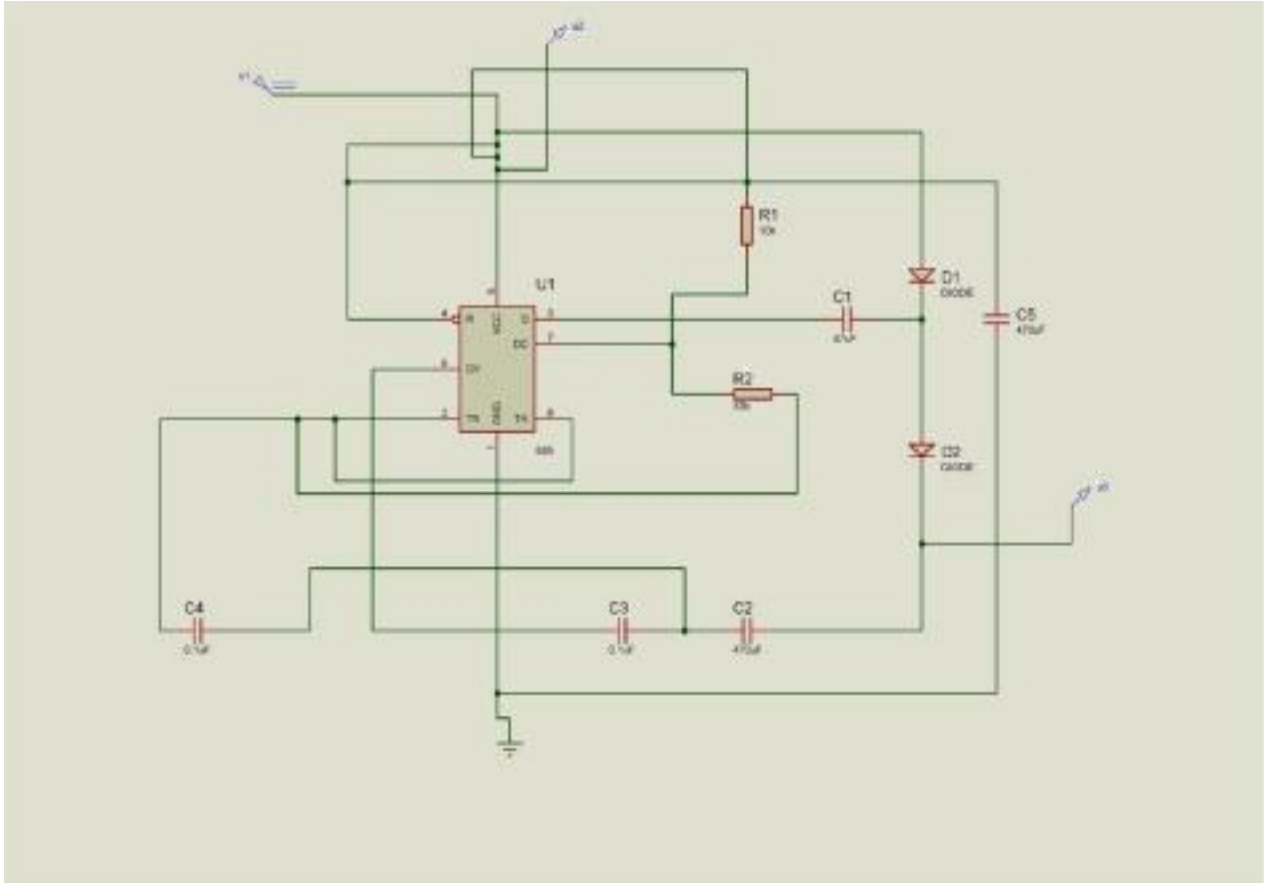

Circuit diagram of voltage doubler using 555 timer IC is successfully run in **proteus 8 software**.

## OBSERVATION TABLE AND RESULTS

Sl. No.	Supply Voltage( $V_s$ )	Desired Output Voltage ( $V_d$ )	Actual Output Voltage ( $V_o$ )	Difference (D)
1	2	4	3.7	0.3
2	4	8	7.4	0.6
3	6	12	11.4	0.6
4	8	16	14.9	1.1
5	9	18	16.7	1.3
6	12	24	22.4	1.6

The result has been shown perfectly. The output voltage is twice the input voltage. If we supply 5V at the input then we are getting 9.5V at the output voltage. The reduction in 5% of voltage is due to the circuit element (mainly due to diodes which 0.7V). The following pictures are showing the results.

## CONCLUSION

The 555 timer output voltage is made to pass through the voltage doubler circuit for doubling the output voltage. But for maintaining good voltage regulation and to evade output voltage from falling below the estimate level, we must limit the load to less than 5mA. Thus by estimating the high current drawing loads we can evade the poor voltage regulation. By adding more number of multiple stages, we can obtain an output voltage that is equal to three to six times the input voltages. We can also use voltage divider to get half, one-fourth, one-eighth of DC voltages.



# APENDIX A

## HARDWARE COMPONENTS WITH SPECIFICATIONS

### 1. 555 TIMER:

The 555 timer IC is an integrated circuit (chip) used in variety of timer, pulse generation and oscilloscope applications. The 555 timer can be used to provide time delays, as an oscillator and as a flip-flop element. Derivatives provide up to four timing circuits in one package.

Introduced in 1971 by American company Signetics, the 555 is still in widespread use due to low price, ease of use, and stability. It is now made by many companies in the original bipolar and in low power CMOS types.

#### **The IC 555 has three operating modes:**

**Bistable** mode or Schmitt trigger – the 555 can operate as a flip-flop, if the DIS pin is not connected and no capacitors is used. Uses include bounce-free latched switches.

**Monostable** mode – in this mode, the 555 functions as a one-shot pulse generator. Applications include timers, missing pulse detection, bounce free switches, frequency divider, capacitance measurement, pulse-width modulation (PWM) and so on.

**Astable**(free running) mode – the 555 can operate as an electronic oscillator. Uses include LED and lamp flashers, pulse generators, logic clocks, tone generation, security alarms, pulse positions modulation and so on. The 555 timer can be used as a simple ADC, converting an analog value to a pulse length e.g., selecting a thermistor as timing resistor allows the use of the 555 in a temperature sensor and the period of the output pulse is determined by the temperature.

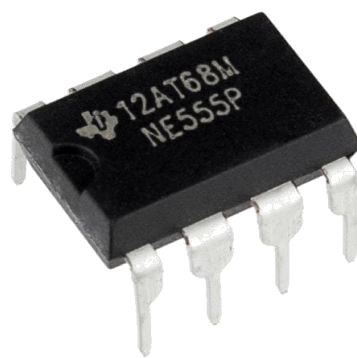

555 timer IC

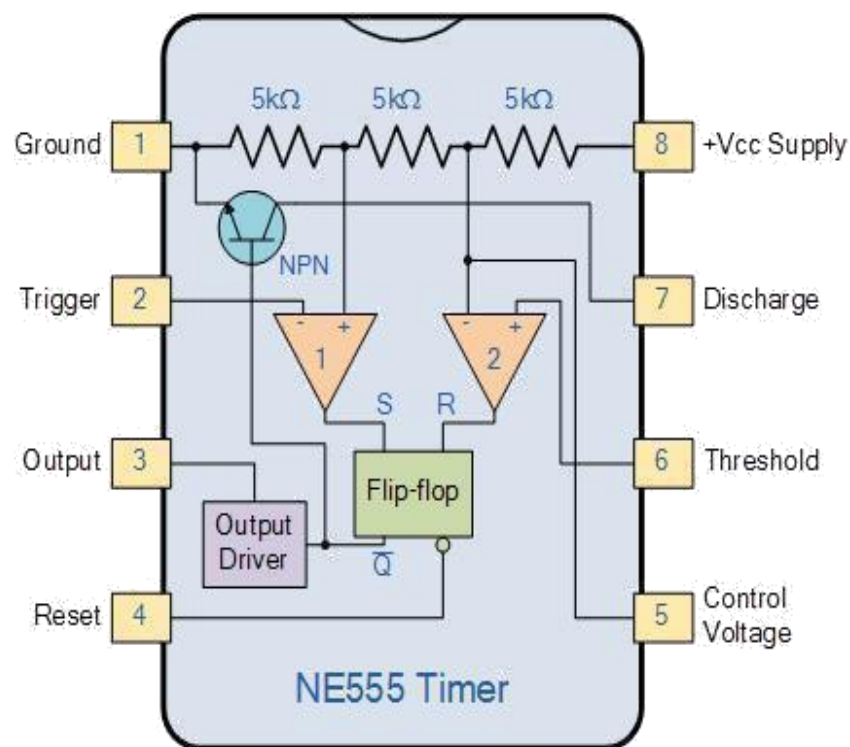

Internal structure of 8 pin 555 timer IC

## 2. Diodes:

Diode, an electrical component that allows the flow of current in only one direction. That is the current should always flow from the Anode to cathode. The cathode terminal can be identified by using a grey bar in practical picture.

The most common type of diode uses a p-n junction. In this type of diode, one material (n) in which electrons are charge carriers abuts a second material (p) in which holes (places depleted of electrons that act as positively charged particles) act as charge carriers. At their interface, a depletion region is formed across which electrons diffuse to fill holes in the p-side. This stops the further flow of electrons. When this junction is forward biased (that is, a positive voltage is applied to the p-side), electrons can easily move across the junction to fill the holes, and a current flows through the diode. When the junction is reverse biased (that is, a negative voltage is applied to the p-side), the depletion region widens and electrons cannot easily move across. The current remains very small until a certain voltage (the breakdown voltage) is reached and the current suddenly increases.



1N4007 diode picture

For 1N4007 Diode, the maximum current carrying capacity is 1A it withstand peaks up to 30A. Hence we can use this in circuits that are designed for less than 1A. The reverse current is 5 $\mu$ A which is negligible. The power dissipation of this diode is 3W.

## **Specifications of 1N4007 Diodes:**

Average forward current is 1A

Non-repetitive Peak current is

30A Reverse current is 5uA.

Peak repetitive Reverse voltage is

1000V Power dissipation 3W

Available in DO-41 Package

We are using two diodes for the voltage doubler using 555 timer circuit and another four 1N4007 diodes for rectifier circuit.

### 3.RESISTORS:

A resistor is an electrical element that limits or regulates the flow of electrical current in the circuit. It is a passive element means it cannot generate signal.

All other factors being equal, in a direct-current (DC) circuit, the electric current through a resistor is inversely proportional to its resistance, and directly proportional to the voltage across it.

According to the Ohm's Law:

I is proportional to V (Temperature is constant)

$I = V/R$  (1/R is proportional constant)

$R=V/I$

Resistor does not depend on voltage or current but it depends on the ratio of V to I. If the resistor does not depend on current then it is linear otherwise it is non-linear.

Resistor depends upon the type of material and dimensions but resistivity only depends upon type of material. Unit of Resistance is ohm.

Reciprocal of resistance is conductance

$G = 1/R = I/V$  (Mho or Siemen)

Reciprocal of Resistivity is called Conductivity

$\sigma = 1/\rho = L/RA$  (1/ -m or Siemens/m)

Resistors can be made-up in a variety of ways. Most common type of resistor is graphite mixed with clay and then hard-bitten.

Resistor depends on temperature.

$R_2 = R_1(1+\alpha_1(t_2 - t_1))$

Where  $\alpha_1$  is temperature coefficient

Another type of resistor is made from Nichrome. The component is made up of wound wire resistor. The resistor can handle higher amount of currents having the same composition and physical size of the normal resistor.



Various type of resistors

### **Specifications of 33k Resistors:**

4. Resistance (Ohms) - 33K
5. Power (Watts) - 1W
6. Tolerance -  $\pm 5\%$
7. Composition - Metal Oxide Film
8. Temperature Coefficient -  $\pm 300\text{ppm}/^\circ\text{C}$
9. Lead Free Status - Lead Free
10. RoHS Status - RoHS Compliant

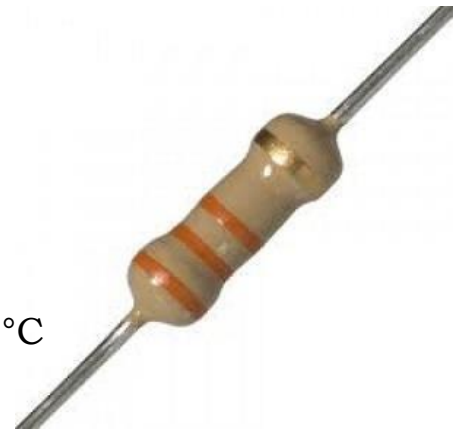

### **Specifications of 10k Resistors:**

5. Resistance (ohm) - 10000
6. Power (Watts) - 0.25
7. Tolerance (%) - -5
8. Package - Axial Leaded
9. Product Type - Resistor
10. Size - Standard
11. Mounting Feature - Through Hole
12. Resistor Type - Carbon Film
13. Maximum working voltage: 250V





#### 4.Capacitors:-

A capacitor is two parallel plate passive electronic component that stores the energy in the form of an electrostatic field. In its simplest form, a capacitor consists of two conducting plates separated by an insulating material called the dielectric. The charge on the capacitor is proportional to supply voltage.

$q$  is directly proportional to  $V$

$q = CV$  ( $C$  is prop. Constant)

$C=q/V$  (Farads)

The capacitance of parallel plate is directly proportional to the surface areas of the plates( $A$ ), and is inversely proportional to the separation between the plates ( $d$ ). Capacitance also depends on the dielectric constant of the substance.

$C$  is proportional to  $A$

$C$  is inversely proportional to  $d$

$C = \epsilon A/d$

$\epsilon = \epsilon_0 \epsilon_r$

$\epsilon_0 = \text{Absolute Permittivity} = 8.85 \times 10^{-12} \text{ F/m}$

If the capacitance doesn't depend upon on voltage then it is known as Linear capacitor otherwise non-Linear.

The standard unit of capacitance is the farad. However, this is a large unit; most common units are the microfarad, abbreviated  $\mu\text{F}$  ( $1 \mu\text{F} = 10^{-6} \text{ F}$ ) and the picofarad, abbreviated  $\text{pF}$  ( $1 \text{ pF} = 10^{-12} \text{ F}$ ).

## Specifications of 33k capacitors:

Package - 10\*17

Manufacturer - LCSC

Operating Temperature -  $-40^{\circ}\text{C}$  -  $+105^{\circ}\text{C}$

Capacitance - 1000uF

Lead Spacing - 5

Size(mm) - 10x16

Lifetime - 2000Hrs

Voltage - Rated - 25V

Tolerance -  $\pm 20\%$

Temperature -  $105^{\circ}\text{C}$

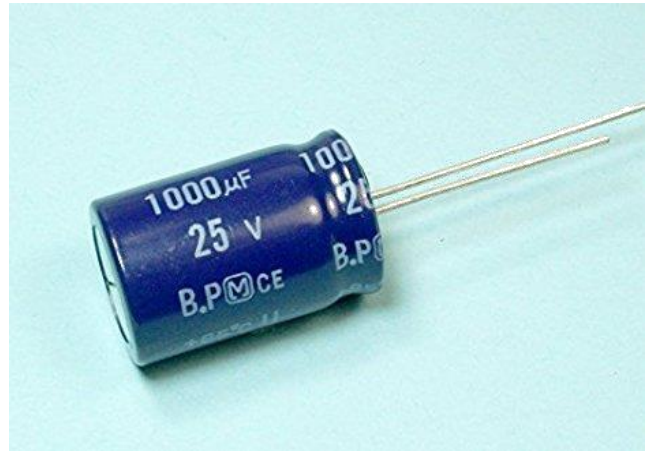

## Specifications of 0.1uF capacitors:

50V Rated

0.1µF

Z5U Temperature Coefficient

$\pm 20\%$  Tolerance

Radial Case with .100" Lead Spacing



## 14. Transformer:

A transformer is a device that step-up and step-down alternating potential without change in frequency. It works on principle of mutual Induction.

A transformer consists of a soft iron coil with two coils wound around it which are electrically not connected to one another. They are mutually connected. The flux produce is mutually coupled.

The coil to which the alternating voltage is supplied is called the primary coil or primary winding. Due to alternating voltage a potential difference is developed which is supplied to the primary winding the resulting alternating current in the primary coil produces a changing magnetic field around it. This changing field induces an alternating current in the secondary coil. The size of the induced voltage resulting from the induced current in the secondary coil depends on the number of turns in the secondary coil.

### **Step down transformer:**

A transformer in which the output (secondary) voltage is less than its input (primary) voltage is called a step-down transformer. The number of turns on the primary side of the transformer is greater than the turn on the secondary side of the transformer, i.e.,  $T_2 < T_1$ . The step-down transformer is shown in the figure below.

step-up transformer The voltage turn ratio of the step-down transformer is 2:1. The voltage turn ratio determines the

magnitude of voltage that transform from primary to secondary windings of the transformer.

Step-down transformer is made up of two or more coil wound on the iron core of the transformer. It works on the principle of magnetic secondary windings of the transformer. Thus the voltage transforms from primary to the secondary winding of the transformer.

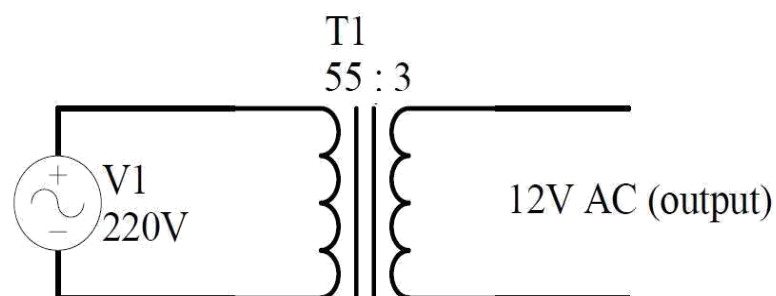

### **Ratings of transformer:**

PRIMARY VOLTAGE: 230 VAC

SECONDARY VOLTAGE: 12 VAC

STANDARD: According to EN-61558-2-6

ISOLATION CLASS: T40/B

DIELECTRIC STRENGTH: 4600V

(between primary and secondary)

2300V (between primary and mass)

PROTECTION DEGREE: IP00

PROTECTION CLASS: I

FREQUENCIES: 50 Hz

CONNECTION: Screw faston terminals

WINDING: Enamelled copper wire class H separated primary and secondary



## 6. DC Motor:

Motor is a device which transforms the electrical energy into mechanical energy. The working principle of the motor is the interaction between the magnetic field and the current to produce a force within the motor which helps the motor to do work.

The motor principle is basically based on Faraday's Law, which states that, it is the conservation of electrical and mechanical energy.

DC motor is one type of motor that uses the DC current to convert electrical energy into mechanical energy.

When the electric current passes through a coil in a magnetic field, a magnetic force will be generated, which produces a torque in the DC motor.

### **Dc motor rating:**

RPM: 300 at 12V

Voltage: 4V to 12V

Stall torque: 23Kg-cm at stall  
current of 8.4A@12V Shaft

diameter: 8mm Shaft length:

17.5mm Gear assembly: Spur

Brush type: Carbon Motor

weight: 280gms

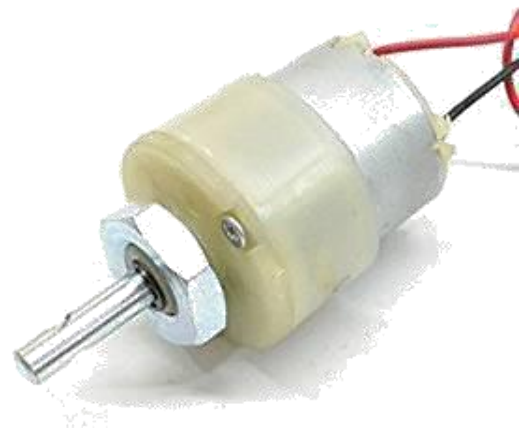

## 7. Voltage regulator:

A voltage regulator is an electronic circuit that maintains constant output voltage independent of the variations in input voltage and load resistance.

It rejects power surges, spikes which can cause harm to sensitive electronics.

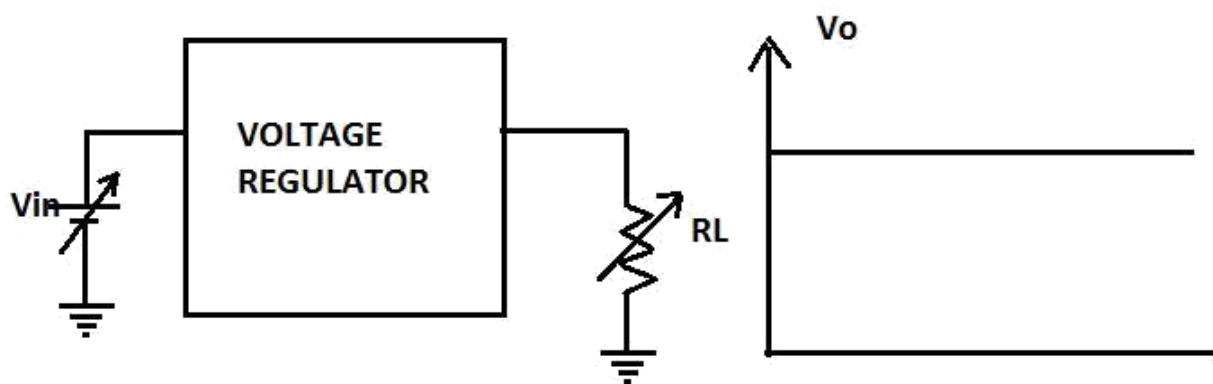

7812 Voltage regulator is a one of the type of fixed linear voltage regulator circuit. It belongs to IC 78xx voltage regulator family.

The 7812 voltage regulator IC is easily to use and available at cheap cost.

The last two digits of 7812 indicates the output voltage which is 12 V.

The IC 7812 is a positive voltage regulator which means that it produces the positive voltage with respect to the ground.

## **Specifications of 7812 voltage regulator**

Output Type: Fixed

Output Voltage: +12V DC

Current Output: up to 1.5A

Input Voltage: 14 - 36VDC

Quiescent (standby) current: 8mA

Dropout Voltage (Max): 2V

Current: 1A

Category: Linear Voltage Regulators - Standard

Polarity: Positive

Operating Temperature: 0 to 125°C

Mounting Style: Through Hole Pin

Spacing Pitch: 2.54mm

Dimensions: 10.4 x 4.6 x 9.15mm

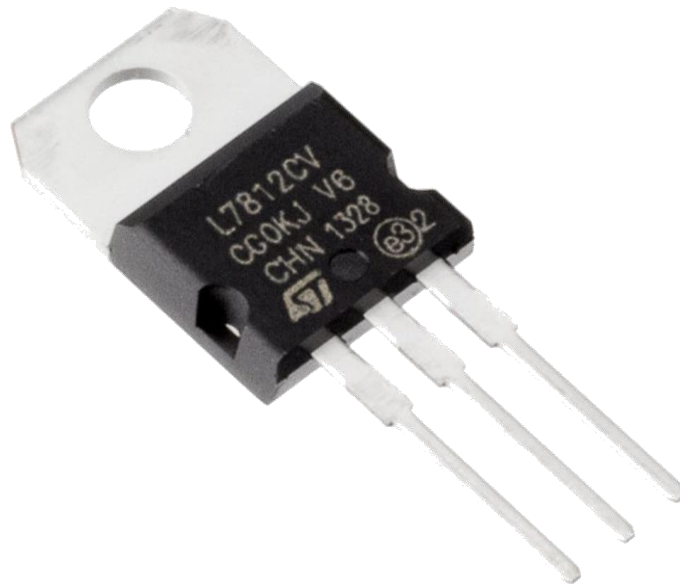

7812 voltage regulator IC

## Specifications of LM317T Voltage Regulator

The LM317T is a positive adjustable voltage regulator designed to supply more than 1.5 A of load current with an output voltage adjustable over a 1.2 to 37 V range. The nominal output voltage is selected by means of only a resistive divider, making the device exceptionally easy to use and eliminating the stocking of many fixed regulators.:-

0.1 % line and load regulation

Floating operation for high voltages

Current limiting, Thermal shutdown and SOA control

**Applications:** -Power Management

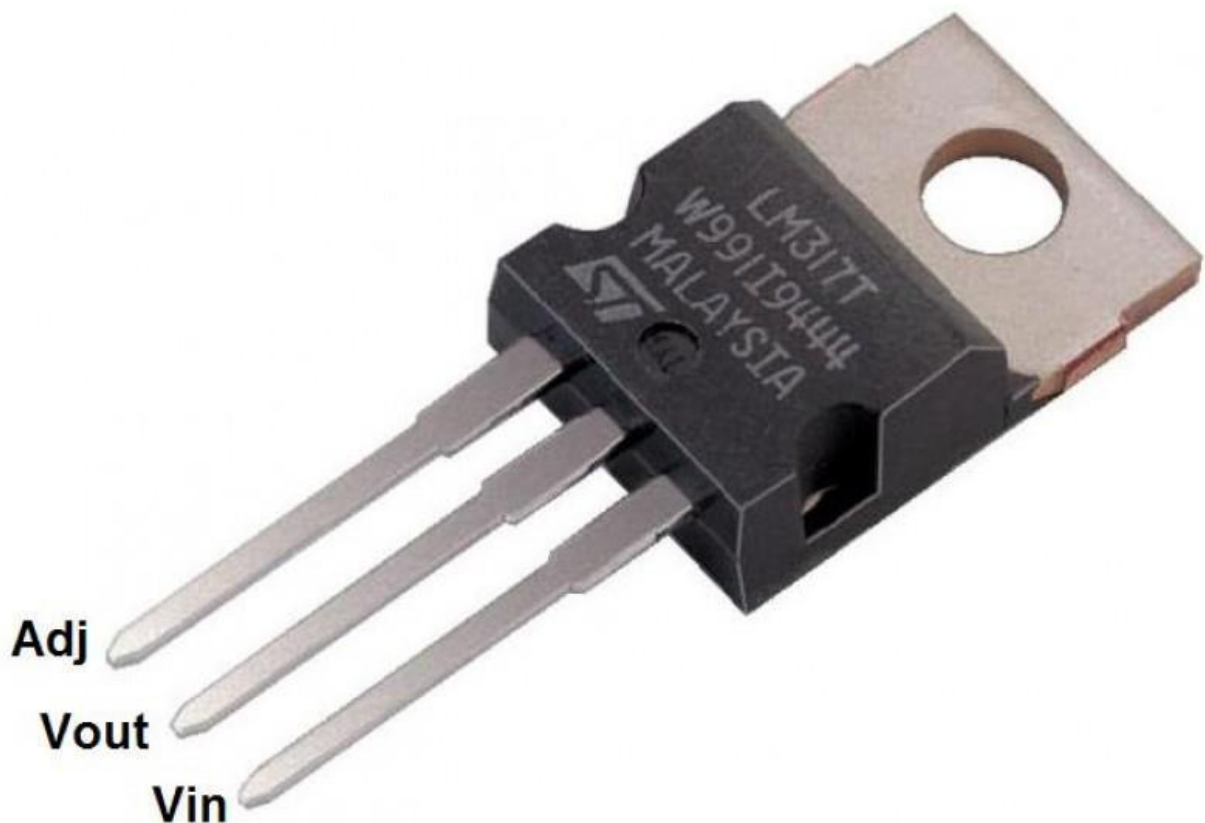



## 8. Potentiometer:

A potentiometer is a physically adjustable variable resistor with 3 terminals. Two terminals are connected to two ends of a resistive element, and the third terminal connects to a sliding contact, called a wiper, moving over the resistive element. The position of the wiper determines the input voltage of the potentiometer. The potentiometer basically functions as a variable voltage divider. The resistive element can be seen as two resistors connected in series (potentiometer resistance), where the wiper position determines the resistance ratio of the first resistor to the second resistor.

A potentiometer is also commonly known as a potentiometer or pot. The most common form of potentiometer is the single turn rotary potentiometer. This type of pot is often used in audio volume control (logarithmic taper) as well as many other applications. Different materials are used to construct potentiometers, including carbon composition, cermet, wire wound, conductive plastic or metal film.

### Specifications of potentiometer:

- Type: Rotary also known as Radio POT
- Resistance: 10k
- Power Rating: 0.3W
- Maximum Input Voltage: 200Vdc
- Rotational Life: 2000K cycles

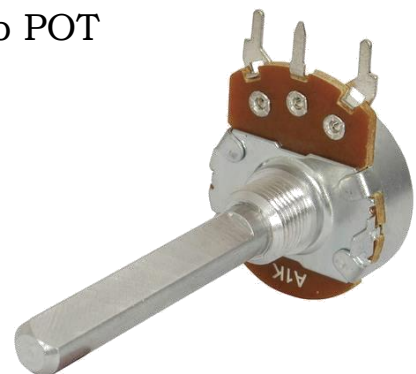

## 9. Rectifier circuit:

A rectifier is an electrical device consists of two or more diodes connected appropriately that converts alternating current (AC) to direct current (DC). A diode is like a one-way valve that allows an electrical current to flow in only one direction and block in reverse direction. Diode is unilateral element means that element characteristics are not same in both directions of current. This process is called rectification.

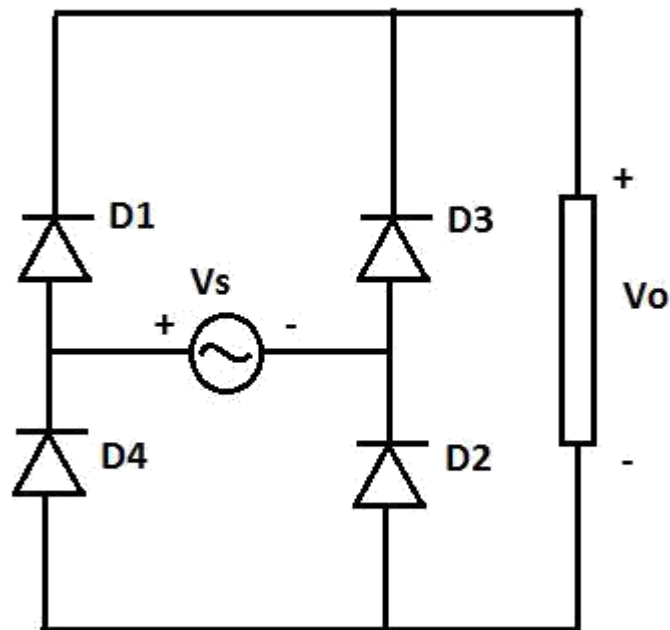

A rectifier can take the shape of several different physical forms such as solid-state diodes, vacuum tube diodes, mercury arc valves, silicon-controlled rectifiers and various other silicon-based semiconductor switches.

A rectifier is an electrical device that converts AC to DC. AC regularly reverses direction, while DC flows in one direction only.

Rectification produces a type of DC that encompasses active voltages and currents, which are then adjusted into a type of constant voltage DC, although this varies depending on the current's end use. The current is allowed to flow uninterrupted in one direction, and no current is allowed to flow in the opposite direction.

Almost all rectifiers contain more than one diode in particular arrangements. A rectifier also has different waveforms, such as:

**Half Wave:** In this case either positive or negative wave pass through and other is block. It is not much efficient because only half of the input waveform reaches the output.

**Full Wave:** In this case it reverse the negative part of voltage and then double the output by combining with the positive part.

**Single-Phase AC:** Two diodes can form a full-wave rectifier if the transformer is centre-tapped. Four diodes arranged in a bridge are needed if there is no centre-tap.

**Three-Phase AC:** Usually uses three pairs of diodes

## **CLASSIFICATION OF RECTIFIER**

**Uncontrolled Rectifier:** It convert fixed AC supply into fixed DC supply. It uses only diodes.

**Half Controlled Rectifier (Semi Converter):** It convert fixed AC supply into variable DC supply. It uses both diodes and SCR.

**Fully Controlled Rectifier (Full Converter):** It convert fixed AC supply into variable DC supply. It uses SCR only.

Rectifiers are used in various devices, including:

DC power supplies

Radio signals or detectors

A source of power instead of generating current  
High-voltage direct current power transmission systems

Several household appliances use power rectifiers to create power, like notebooks or laptops, video game systems and televisions.

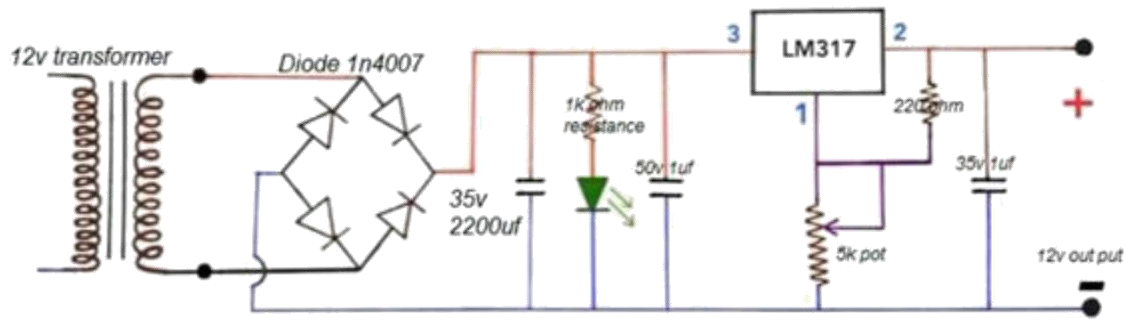

Circuit diagram of rectifier

**Lists of components of rectifiers:**

1. Four diodes – 1N4007
2. Two capacitors – 2200uF, 470uF
3. Two resistors – 1k, 220 Ohm
4. Transformer – 230/12VAC
5. Regulator – lm317t

## **10. APPLICATIONS:**

Cathode ray tubes.

X- Ray systems.

Laser systems.

Computer applications.

## **11. ADVANTAGES**

Construction is simple.

Less cost & size.

It doubles input voltage.

## 12. DISADVANTAGES

However, this circuit is very useful to generate higher voltage from a low power source, but this can only deliver up to 50mA current. So it should only be used for low current driven applications.

Also the output voltage may be unstable, so a voltage regulator (IC78XX) of proper rating can be used regulation and smooth output. But voltage regulator IC itself consume some current, and reduce the deliverable current (must not exceed 70mA).

## **REFERENCES**

1. Analog Electronic Circuits by Soumitra K. Mandal
2. Power electronics: converters, device, and Applications by  
M.H. Rashid
3. Power electronics by P.S Bimbhra
4. Power electronics by M.D. Singh and K.B. Kanchandani
5. Power electronics by V.R. Moorthi



