

# **SPEED CONTROL OF DC MOTOR USING PULSE WIDTH MODULATION**

*A Project report submitted in partial fulfilment  
of the requirements for the degree of B. Tech in Electrical Engineering*

*By*

**RUPESH KUMAR (EE2015/043)**

**MRITUNJOY RAY (EE2015/001)**

**SRIDEEP BASAK (EE2015/009)**

**TITAS RAY (EE2016/L02)**

*Under the supervision of*

**Mr. DIPANKAR SANTRA**

**ASSOCIATE PROFESSOR**

*Co-Guide*

**MR. SARBOJIT MUKHERJEE**

**ASSISTANT PROFESSOR**

**DEPARTMENT OF ELECTRICAL ENGINEERING**



*Department of Electrical Engineering*

**RCC INSTITUTE OF INFORMATION TECHNOLOGY**

**CANAL SOUTH ROAD, BELIAGHATA, KOLKATA – 700015, WEST BENGAL**

**Maulana Abul Kalam Azad University of Technology (MAKAUT)**

© 2019

## **ACKNOWLEDGEMENT**

It is my great fortune that I have got opportunity to carry out this project work under the supervision of **Mr. Dipankar Santra** and **Mr. Sarbojit Mukherjee** in the Department of Electrical Engineering, RCC Institute of Information Technology (RCCIIT), Canal South Road, Beliaghata, Kolkata-700015, affiliated to Maulana Abul Kalam Azad University of Technology (MAKAUT), West Bengal, India. I express my sincere thanks and deepest sense of gratitude to my guide for his constant support, unparalleled guidance and limitless encouragement.

I wish to convey my gratitude to Prof. (Dr.) Debasish Mondal, HOD, Department of Electrical Engineering, RCCIIT and to the authority of RCCIIT for providing all kinds of infrastructural facility towards the research work.

I would also like to convey my gratitude to all the faculty members and staffs of the Department of Electrical Engineering, RCCIIT for their whole hearted cooperation to make this work turn into reality.

**Full Signature of Students**

**Place:**

**Date:**

## CERTIFICATE

### To whom it may concern

This is to certify that the project work entitled **SPEED CONTROL OF DC MOTOR USING PULSE WIDTH MODULATION** is the bonafide work carried out by **Rupesh Kumar ,Mritunjoy Ray ,Srideep Basak ,Titas Ray** a student of B.Tech in the Dept. of Electrical Engineering, RCC Institute of Information Technology (RCCIIT), Canal South Road, Beliaghata, Kolkata-700015, affiliated to Maulana Abul Kalam Azad University of Technology (MAKAUT), West Bengal, India, during the academic year **2018-19**, in partial fulfillment of the requirements for the degree of Bachelor of Technology in Electrical Engineering and that this project has not submitted previously for the award of any other degree, diploma and fellowship.

---

**Signature of the Guide**

**Name: DIPANKAR SANTRA**

**Designation: ASSOCIATE PROFESSOR**

---

**Signature of the HOD**

**Name: Dr. DEBASISH MONDAL**

**Designation: ASSOCIATE  
PROFESSOR & HOD**

---

**Signature of the Co-Guide**

**Name: SARBOJIT MUKHERJEE**

**Designation: ASSISTANT PROFESSOR**

---

**Signature of the External Examiner**

**Name:**

**Designation:**

## **TABLE OF CONTENTS:**

<i>List of Figures</i>	<i>i</i>
<i>Abstract</i>	<i>iii</i>
1. INTRODUCTION	1
2. DC MOTOR	2
2.1. INTRODUCTION TO SPEED CONTROL	2
2.2. CLASSIFICATION OF DC MOTORS	2
2.3. SPEED CONTROL METHODS	4
2.3.1. FLUX CONTROL METHOD	4
2.3.2. ARMATURE AND RHEOSTAT CONTROL METHOD	5
2.3.3. VOLTAGE CONTROL METHOD	7
2.3.3.1. MULTIPLE CONTROL VOLTAGE	7
2.3.3.2. WARD LEONARD SYSTEM	7
2.3.4. PWM TECHNIQUE	9
3. PWM TECHNIQUE	10
4. DC MOTOR SPEED CONTROL USING PWM METHOD	12
4.1. PRINCIPLE	12
4.2. METHODS	14
4.2.1. ANALOGUE METHOD	14
4.2.2. DIGITAL METHOD	15
4.2.3. PWM GENERATOR CHIP	15
5. SOLDERING	16
5.1. SOLDERING IRON	16
5.2. SOLDERING STATION	16
5.3. SOLDERING IRON TIPS	16
5.4. BRASS OR CONVENTIONAL SPONGE	17
5.5. SOLDERING IRON STAND	17
5.6. SOLDER	17
6. BLOCK DIAGRAM	18
6.1. BLOCK DIAGRAM DESCRIPTION	19
6.1.1. POWER SUPPLY	19
6.1.2. ICC 555 TIMER	20
6.1.2.1. PIN DIAGRAM OF IC 555 TIMER	21
6.1.2.2. 555 TIMER WORKING	22
6.1.3. TRANSISTOR	23

6.1.3.1. APPLICATION	24
6.1.4. DC MOTOR	24
6.1.5. POTENTIOMETER	25
7. COMPONENTS	26
7.1. COMPONENTS REQUIRED FOR SPEED CONTROL	26
7.2. COMPONENT LIST OF 12V POWER SUPPLY	26
8. CIRCUIT DIAGRAM	27
8.1. CIRCUIT DIAGRAM FOR SPEED CONTROL	27
8.1.1. WORKING OF THE CIRCUIT	28
8.2. CIRCUIT DIAGRAM FOR 12V POWER SUPPLY	29
8.2.1. WORKING OF THE CIRCUIT	29
9. HARDWARE MODEL	33
10.RESULT AND DISCUSSION	34
11.CONCLUSION	37
12.FUTURE SCOPE	38
APPENDIX A:	
A.1. SPECIFICATIONS OF HARDWARE COMPONENTS	39
REFERENCES	42

## **List of Figures:**

<b><i>Figure</i></b>	<b><i>Page No.</i></b>
<i>1. Types of Motor</i>	<i>2-3</i>
<i>2. Flux Control Method</i>	<i>5</i>
<i>3. Armature or rheostat Control Method</i>	<i>5</i>
<i>4. Speed vs Armature Current Graph</i>	<i>6</i>
<i>5. Structural Arrangement of Ward Leonard System</i>	<i>8</i>
<i>6. 5V Pulses With 0% through 100% duty cycle</i>	<i>10</i>
<i>7. Simple Speed Controller</i>	<i>11</i>
<i>8. Pulse Width Modulation Waveform</i>	<i>13-14</i>
<i>9. Block Diagram of an Analogue PWM Generator</i>	<i>14</i>
<i>10. Block Diagram</i>	<i>18</i>
<i>11. 12V Power Supply</i>	<i>19</i>
<i>12. Pin Diagram of IC555 Timer</i>	<i>21</i>
<i>13. IC555 Timer</i>	<i>23</i>
<i>14. Darlington Pair npn Transistor</i>	<i>23</i>
<i>15. TIP122</i>	<i>24</i>
<i>16. 12 Volt DC Motor</i>	<i>25</i>
<i>17. Potentiometer</i>	<i>25</i>
<i>18. Circuit Diagram for Speed Control</i>	<i>27</i>
<i>19. Circuit Diagram for 12 V Supply</i>	<i>29</i>
<i>20. Full Wave Bridge Rectifier with I/p and O/p Waveform</i>	<i>31</i>
<i>21. 12V Supply Circuit (Hardware)</i>	<i>33</i>
<i>22. Circuit of Speed Control (Hardware)</i>	<i>33</i>
<i>23. Complete Circuit (Hardware)</i>	<i>33</i>

<i>24. Pulse at Different Duty Cycle</i>	<i>35</i>
<i>25. Pulse at Different Frequencies</i>	<i>35</i>
<i>26. Motor Speed and Voltage at Different PWM Frequency</i>	<i>36</i>
<i>27. Motor Speed and Voltage at Different Duty Cycle</i>	<i>36</i>

## **ABSTRACT:**

In Industry DC motor is widely uses for speed control and load characteristics, it's easy controllability provide effective and precise output. So, application of DC motor is large for commercial purpose. Speed control of DC motor is very crucial in application where required speed is precision and correcting signal representing and to operate motor at constant speed ,so we used PWM method which are fulfil all requirements to speed control of DC motor.PWM based speed control system consists of electronic components (integrated circuit ,Potentiometer etc).In this Project 555 timer (NE55P) is being operated in astable mode, which produce a continuous HIGH and LOW pulses. The 555 Timer is capable of generating PWM signal when set up in an astable mode. In this mode, the 555 IC can be used as a pulse width modulator with a few small adjustments to the circuit. The frequency of operation of the circuit is provided by the passive parameters of resistances and capacitors attached to it. The speed control of DC motor is important in applications where precision and protection are of essence. The variable speed drives, till a couple of decades back, had various limitations, such as poor efficiencies, larger space, lower speeds, etc., However, the advent power electronic devices such as power MOSFETs, IGBTs etc., and today we have variable speed drive systems which are not only in the smaller in size but also very efficient, highly reliable and meeting all the stringent demands of various industries of modern era. Direct currents (DC) motors have been used in variable speed drives for a long time. The versatile characteristics of dc motors can provide high starting torques which is required for traction drives. Control over a wide speed range, both below and above the rated speed can be very easily achieved. The methods of speed control are simpler and less expensive than those of alternating current motors.

There are different techniques available for the speed control of DC motors. The phase control method is widely adopted in which ac to dc converters are used to supply the dc motors, but has certain limitations mainly it generates harmonics on the power line and it also has poor p.f. when operated at lower speeds. The second method is pwm technique, which has got better advantages over the phase control.

In order to have better open loop speed control as demand varies frequently like in traction system and many operations in industry must be control manually, PWM is most efficient and



cheap speed control method for dc drives. By varying resistor pot only, we can control the speed of motor states that simple and easy method.

## **1. INTRODUCTION:**

In this project, I will show How Speed Control of DC Motor can be implemented using 555 timer and Pulse Width Modulation (PWM). Most of the industrial process requires to be run on the certain parameters where speed of the drive is concerned. The electric drive systems used in many industrial applications require higher performance, reliability, variable speed due to its ease of controllability. The speed control of DC motor is important in applications where precision and protection are of essence. Purpose of a motor speed controller is to take a signal representing the required speed and to drive a motor at that speed. In this project controller presented uses the pulse width modulation (PWM) technique for speed control of DC motor. We use DC Motors in many systems in our day to day life. For example, CPU fans, fume extinguishers, toy cars etc. are all DC Motors which are operated by DC power supply. Most of the times we will have to adjust the speed of the motors as per our requirement. A CPU Fan for example, must be operated at high speed when the CPU is performing heavy tasks like games or video editing. But for normal usage like editing documents, the speed of the fan can be reduced. Although some systems have an automatic adjustment system for fan speed, not all systems possess this functionality. So, we will have to adjust the speed of the DC Motor ourselves occasionally. The circuit is used to control speed of DC motor by using PWM technique. Series Variable Speed DC Motor Controller 12V uses a 555 timer IC as a PWM pulse generator to regulate the motor speed DC12 Volt. IC 555 is the popular Timer Chip used to make timer circuits. In the Astable mode (AMV), the IC works as a free running multivibrator. The output turns high and low continuously to give pulsating output as an oscillator.

## **2. DC MOTOR**

### **2.1. INTRODUCTION TO SPEED CONTROL:**

Speed control means intentional change of drive speed to a value required for performing the specific work process. This concept of speed control or adjustment should not be taken to include the natural change in speed which occurs due to change in the load on the shaft.

Any given piece of industrial equipment may have its speed change or Adjusted mechanically by means of stepped pulleys, sets of change gears, variable speed friction clutch mechanism and other mechanical devices. Historically it is proved to be the first step in transition from nonadjustable speed to adjustable speed drive. The electrical speed control has many economical as well as engineering advantages over mechanical speed control

The nature of the speed control requirement for an industrial drive depends upon its type. Some drives may require continues variation of speed for the whole of the range from zero to full speed or over a portion of this range, while the others may require two or more fixed speeds

### **2.2. CLASSIFICATION OF DC MOTORS:**

DC motors are classified into three types depending upon the way their field windings are excited. Field windings connections for the three types Of DC motors have been shown in fig.1.

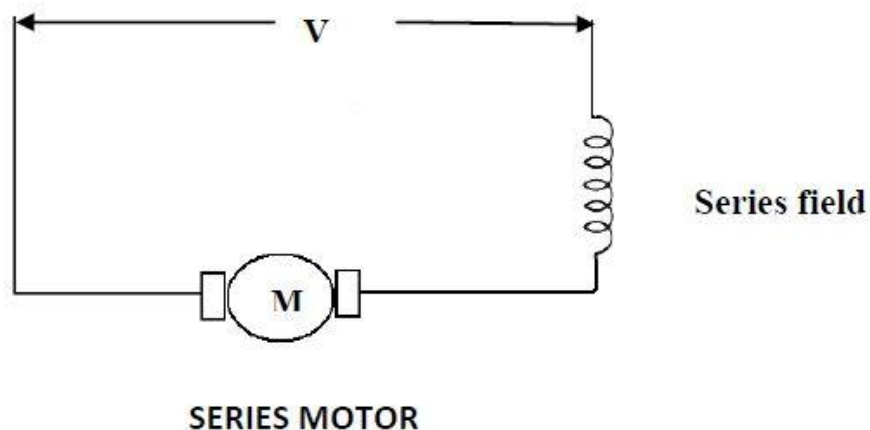

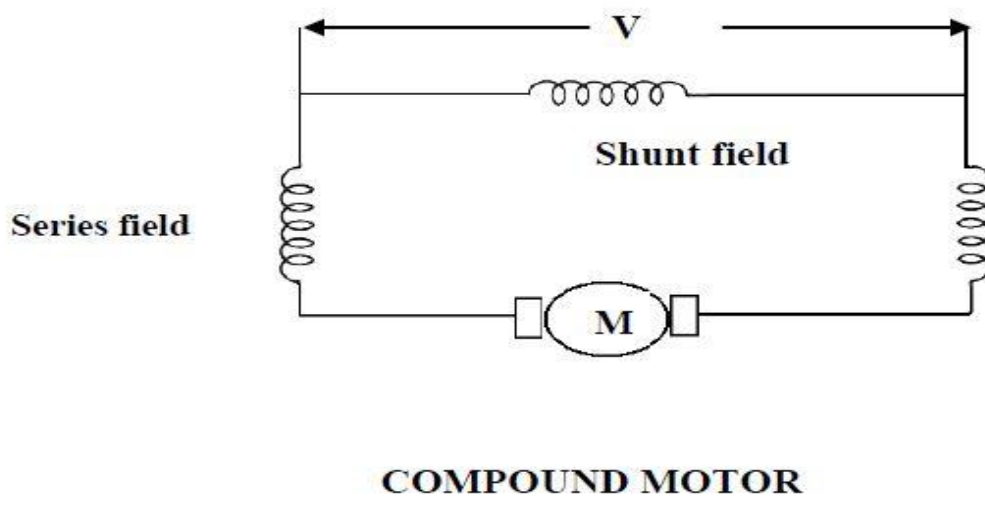
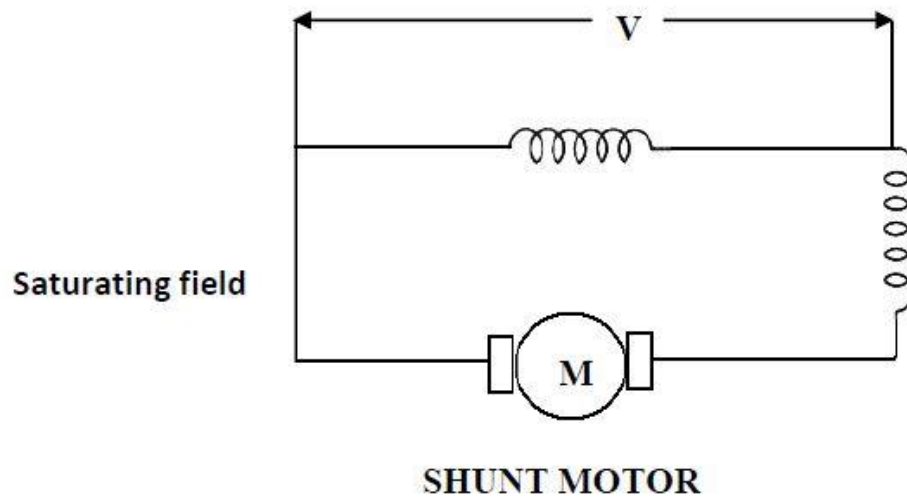

**FIGURE 1**

## 2.3. SPEED CONTROL METHODS

### SPEED CONTROL METHOD OF DC MOTOR:

- Armature or Rheostatic control method.
- Flux control method. It is seen that speed of the motor is inversely proportional to flux.
- Armature control method
- Voltage Control Method
- Variable resistance in series with armature.

### 2.3.1. FLUX CONTROL METHOD:

It is known that  $N \propto 1/\Phi$  by decreasing the flux, thus speed can be increased and vice versa. Hence, name flux or field control method.

The flux of DC motor can be changed by changing  $I_{sh}$  with help of a shunt field rheostat. Since  $I_{sh}$  is relatively small, shunt field rheostat has to carry only a small current, so that rheostat is small in size. This method is therefore very efficient in non-interpole machines the speed can be increased by this method in the ratio 2:1 any further weakening of flux  $\Phi$  adversely affects the commutation

And hence puts a limit to the maximum speed obtainable with this method in machines fitted with interpoles in ratio of maximum to minimum speeds of 6:1 is fairly common.

The connection diagram for this type of speed control is shown in fig 2.

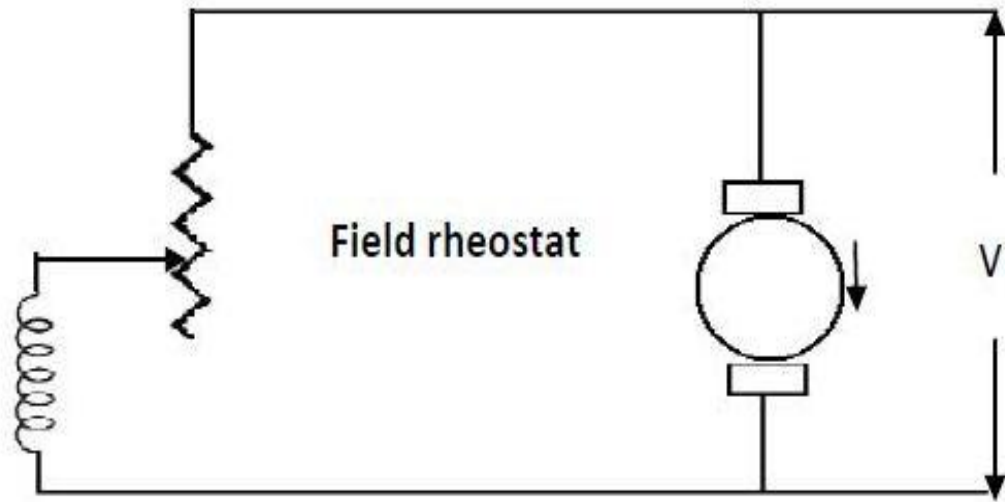

**FIGURE 2: FLUX CONTROL METHOD**

**2.3.2. ARMATURE OR RHEOSTAT CONTROL METHOD:**

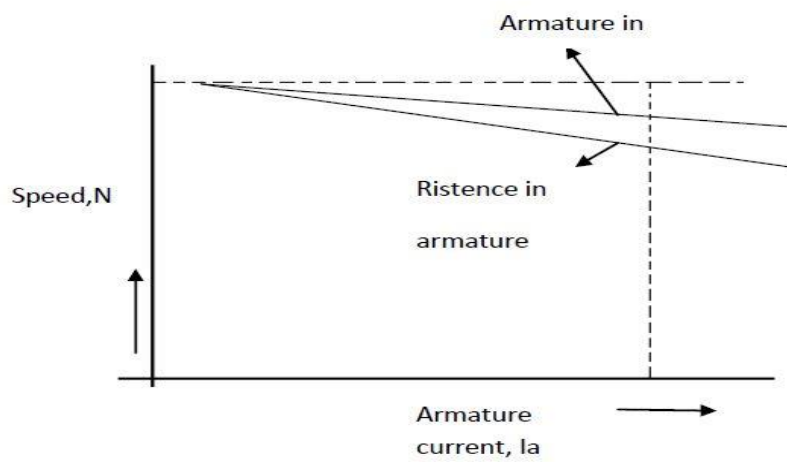
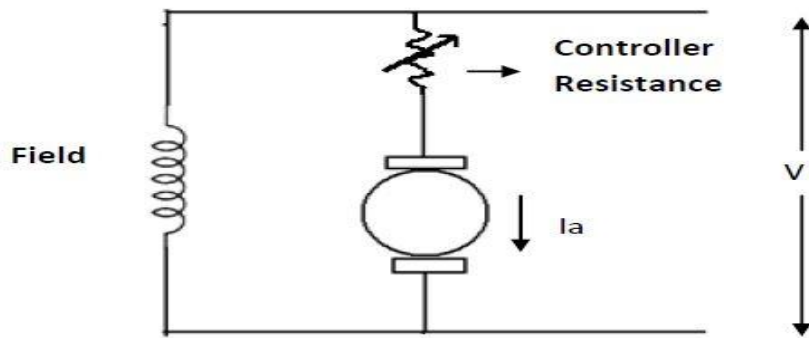

**FIGURE 3: RHEOSTAT CONTROL METHOD**

## Rheostat Control Method and Characteristics

This method is used when speeds below the no load speed are required. As the supply voltage is normally constant, the voltage across the armature is varied by inserting a variable rheostat or controller resistance in series with the armature circuit as shown in fig 3 as controller resistance is increased, potential difference across the armature is decreased, thereby decreasing the armature speed. For a load of constant torque, speed is approximately proportional to the potential difference.

Across the armature current characteristics in fig. in seen that greater the resistance in the armature circuit, greater is the fall in speed.

Let

$I_{a1}$  = Armature current in the first case

$I_{a2}$  = Armature current in the second case

$N_1, N_2$  = corresponding speeds

$V$  = Supply voltage

Then  $N_1 (V - I_{a1} R_a) \propto E_{b1}$

Let some controller resistance of value  $R$  be added to the armature circuit resistance so that its value becomes

$(R + R_a) = R_t$

Then,  $N_2 \propto (V - I_{a2} R_t) \propto E_{b2}$

$N_2/N_1 = E_{b2}/E_{b1}$

Considering no load speed, we have

$N/N_0 = (V - I_{a0} R_t) / (V - I_{a0} R_a)$

Neglecting  $I_{a0} R_a$  w.r.t.  $V$ , we get

$N = N_0 (1 - (I_{a0} R_t) / V)$

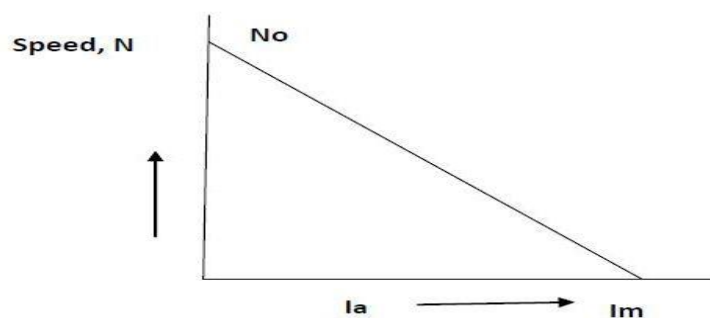

**FIGURE 4: SPEED VS ARMATURE CURRENT**

It is seen that for a given resistance  $R_t$  the speed is a linear function of armature current  $I_a$  as shown in fig. 4

The load current for which the speed would be zero is found by putting  $N=0$  in above relation

$$0 = N_0 \left( \frac{V - I_a R_t}{K \phi} \right)$$

Or

$$I_a = \frac{V}{R_t}$$

This maximum current and is known as stalling current. This method is very wasteful, expensive and unsuitable for rapidly changing loads because for a given value of  $R_t$ , speed will change with load. A more stable operation can be obtained by using a diverter across the armature in addition to armature control resistance.

Now, the changes in armature current will not be so effective in changing the potential difference across the armature. The connection diagram for this type of speed control arrangement is shown in fig.

### **2.3.3. VOLTAGE CONTROL METHOD:**

#### **1) MULTIPLE CONTROL VOLTAGE:**

In this method, the shunt field of the motor is connected permanently to a fixed exciting voltage but the armature is supplied with different voltages by connecting it across one at the several different voltages by means of suitable switchgear. The armature will be approximately proportional to these different voltages. The intermediate speeds can be obtained by adjusting the shunt field regulator.

#### **2) WARD-LEONARD SYSTEM:**

This system is used where an unusually wide (up to 10:1) and very sensitive speed control is required as for colliery winders, electric excavators and the main drives in steel mills and blooming in paper mills.



The field of the motor (M1) is permanently connected across the DC supply lines whose speed control can be done. The other motor M2 is directly connected to Generator G.

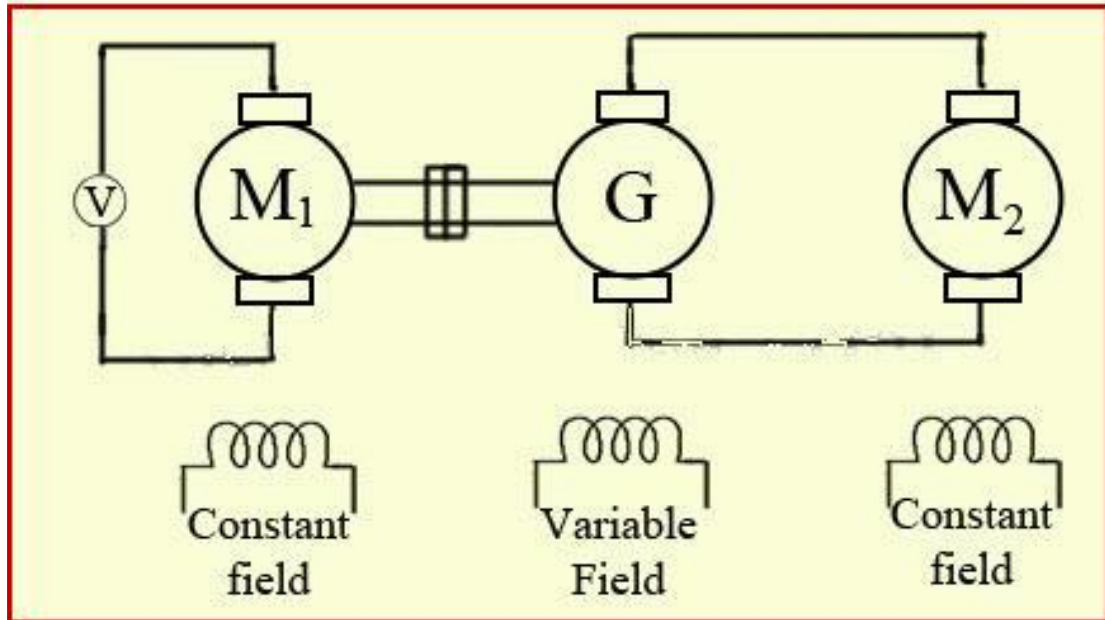

**FIGURE 5: STRUCTURAL ARRANGEMENT OF WARD LEONARD SYSTEM**

The output voltage of G is directly is fed to the main motor M1. The voltage of generator can be varied from zero to up to its maximum value by means of field regulator.

By reversing the direction of the field current of G by means of the reversing switch which RS, generated voltage can be reversed and hence the direction of rotation of M1. It should be remembered that motor set always runs in the same direction.

The addition of a flywheel whose function is to reduce fluctuations in the Power demand from the supply circuit.

The chief advantage of system is its overall efficiency especially at right loads. It has the outstanding merit of giving wide speed Control from maximum in one direction through zero to the maximum in the opposite direction and of giving a smooth acceleration.

### **2.3.4. PWM TECHNIQUE**

Pulse width modulation control works by switching the power supplied to the motor on and off very rapidly. The DC voltage is converted to a square wave signal, alternating between fully on (nearly 12v) and zero, giving the motor a series of power “kicks”.

Pulse width modulation technique (PWM) is a technique for speed control which can overcome the problem of poor starting performance of a motor.

PWM for motor speed control works in a very similar way. Instead of supplying a varying voltage to a motor, it is supplied with a fixed voltage value (such as 12v) which starts it spinning immediately. The voltage is then removed and the motor ‘coasts. By continuing this voltage on/off cycle with a varying duty cycle, the motor speed can be controlled.

### **3. PWM TECHNIQUE:**

Pulse-width modulation (PWM) or duty-cycle variation methods are commonly used in speed control of DC motors. The duty cycle is defined as the percentage of digital 'high' to digital 'low' plus digital 'high' pulse-width during a PWM period.

Fig.2.7 shows the 5V pulses with 0% through 100% duty cycle. The average DC Voltage value for 0% duty cycle is zero; with 20% duty cycle the average value is 1.2V (20% of 5V). With 50% duty cycle the average value is 2.5V, and if the duty cycle is 80%, the average voltage is 4V and so on. The maximum duty cycle can be 100%, which is equivalent to a DC waveform.

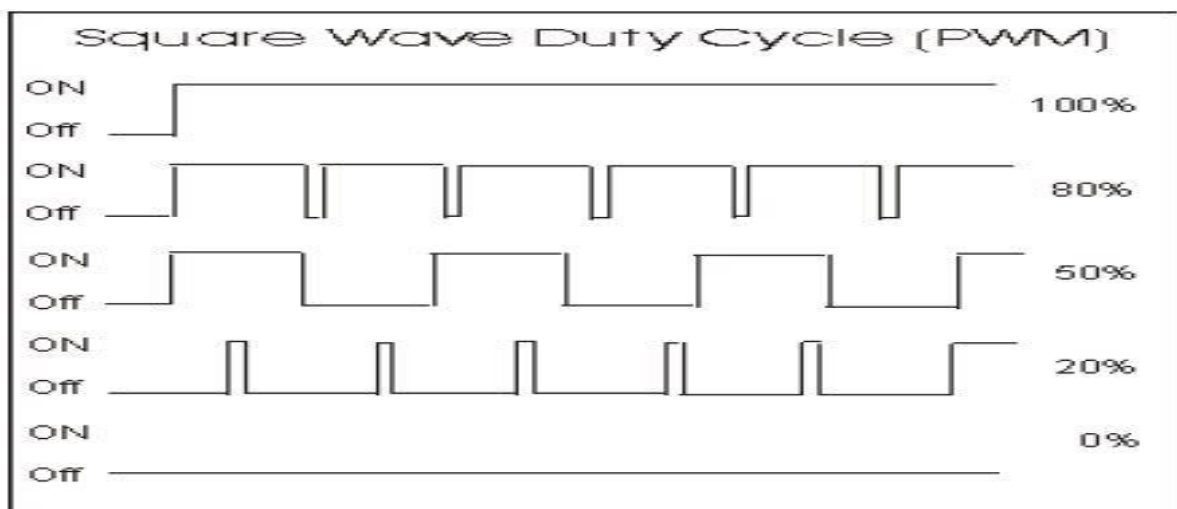

Thus, by varying the pulse-width, we can vary the average voltage across a DC motor and hence its speed.

**FIGURE 6: 5V Pulses With 0% Through 100% Duty Cycle**

The average voltage is given by the following equation:

$$\hat{y} = D \cdot Y_{\max} + (1 - D) Y_{\min}$$

But usually minimum equals zero so the average voltage will be:

$$\hat{y} = D \cdot Y_{\max}$$

The circuit of a simple speed controller for a mini DC motor, such as that used in tape recorders and toys, is shown in Fig 7.

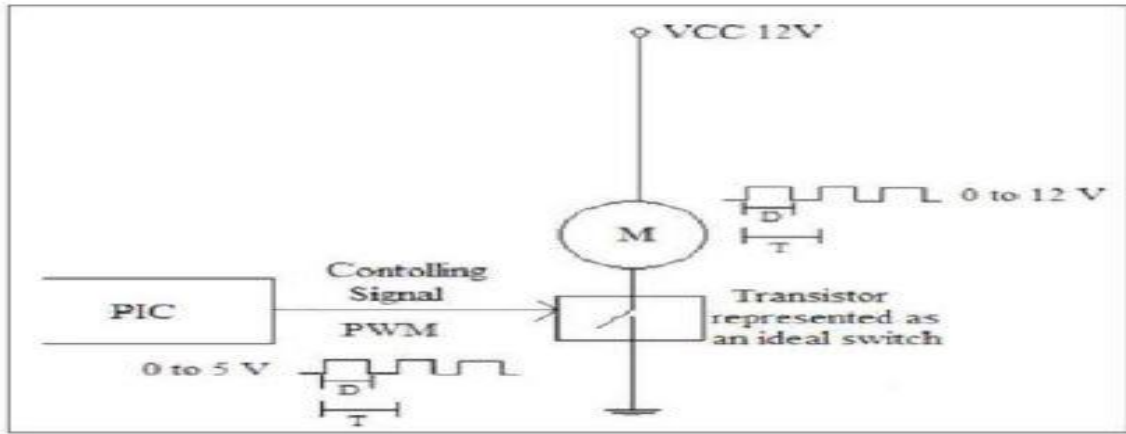

**FIGURE 7: SIMPLE SPEED CONTROLLER**

## **4. DC motor speed control using PWM method:**

The major reason for using pulse width modulation in DC motor control is to avoid the excessive heat dissipation in linear power amplifiers. The heat dissipation problem often results in large heat sinks and sometimes forced cooling. PWM amplifiers greatly reduce this problem because of their much higher power conversion efficiency. Moreover, the input signal to the PWM driver may be directly derived from any digital system without the need for any D/A converters.

The PWM power amplifier is not without disadvantages. The desired signal is not translated to a voltage amplitude but rather the time duration (or duty cycle) of a pulse.

This is obviously not a linear operation. But with a few assumptions, which are usually valid in motor control, the PWM may be approximated as being linear (i.e., a pure gain). The linear model of the PWM amplifier is based on the average voltage being equal to the integral of the voltage waveform. Thus

$$V_S * T_{on} = V_{eq} * T$$

Where

$V_S$  = the supply voltage (+12 volts)

$T_{on}$  = Pulse duration

$V_{eq}$  = the average or equivalent voltage seen by the motor

$T$  = Switching period (1/f)

The recommended switching frequency is 300Hz.

The switching frequency (1/T), is determined by the motor and amplifier characteristics.

The control variable is the duty cycle which is  $T_{on} / T$ . The duty cycle must be recalculated at each sampling time. The voltage that the motor sees is thus  $V_{eq}$ , which is equal to the duty cycle times the supply voltage.

### **4.1. Principle**

Pulse width modulation control works by switching the power supplied to the motor on and off very rapidly. The DC voltage is converted to a square wave signal, alternating between fully on (nearly 12v) and zero, giving the motor a series of power “kicks”.

Pulse width modulation technique (PWM) is a technique for speed control which can overcome the problem of poor starting performance of a motor.

PWM for motor speed control works in a very similar way. Instead of supplying a varying voltage to a motor, it is supplied with a fixed voltage value (such as 12v) which starts it spinning immediately. The voltage is then removed and the motor 'coasts'. By continuing this voltage on/off cycle with a varying duty cycle, the motor speed can be controlled.

The wave forms in the below figure to explain the way in which this method of control operates. In each case the signal has maximum and minimum voltages of 12v and 0v.

- In wave form, the signal has a mark space ratio of 1:1, with the signal at 12v for 50% of the time, the average voltage is 6v, so the motor runs at half its maximum speed.
- In wave form, the signal has mark space ratio of 3:1, which means that the output is at 12v for 75% of the time. This clearly gives an average output voltage of 9v, so the motor runs at 3/4 of its maximum speed.
- In wave form, the signal has mark space ratio is 1:3, giving an output signal that is 12v for just 25% of the time. The average output voltage of this signal is just 3v, so the motor runs at 1/4 of its maximum speed.

By varying the mark space ratio of the signal over the full range, it is possible to obtain any desired average output voltage from 0v to 12v. The motor will work perfectly well, provided that the frequency of the pulsed signal is set correctly, a suitable frequency being 30Hz. setting the frequency too low gives jerky operation. And setting it too high might increase the motor's impedance.

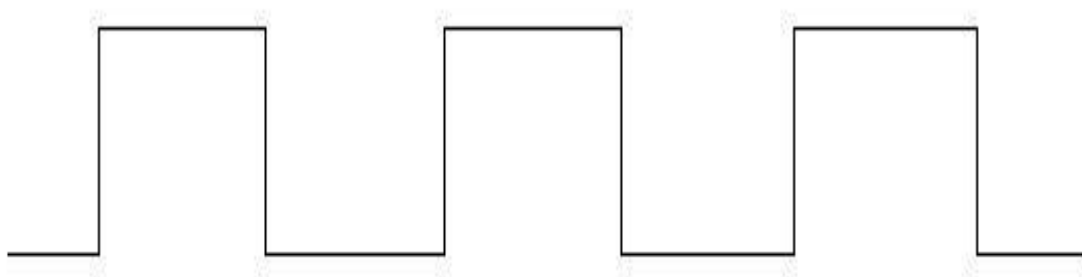

1:1 Mark space ratio (50% duty cycle)

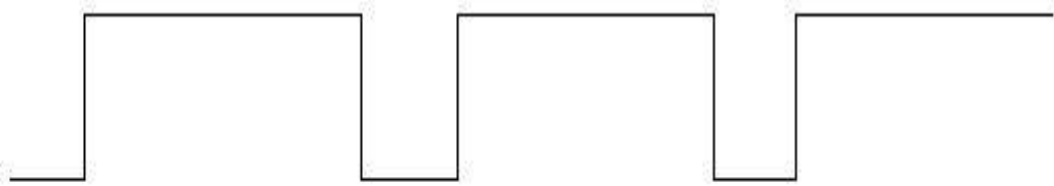

3:1 Mark space ratio (75% duty cycle)

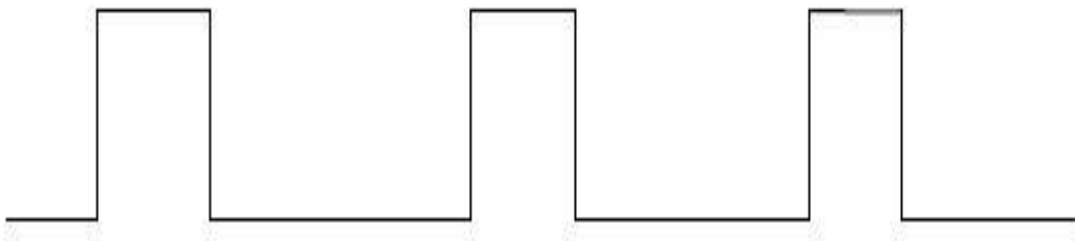

1:3 Mark space ratio (25% duty cycle)

**FIGURE 8: Pulse Width Modulation Waveforms**

## 4.2. METHODS

The pwm signals can be generated in a number of ways. there are several methods:

- analogue method
- digital method
- discrete IC

### 4.2.1. Analogue method:

A block diagram of an analogue PWM generator is

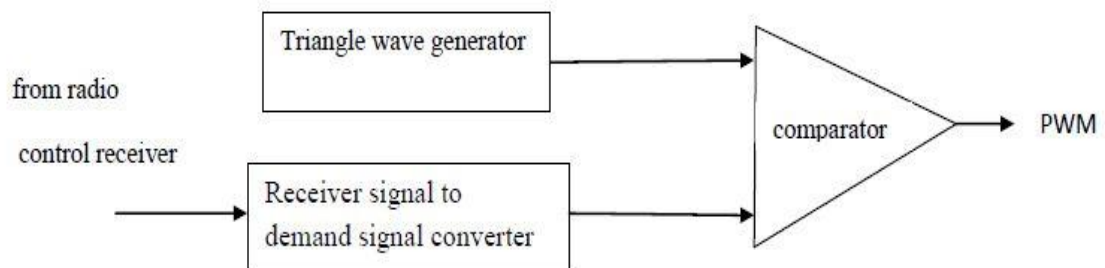

**FIGURE 9: Block Diagram of an Analogue PWM Generator**

The simplest way to generate a PWM signal is the intersective method, which requires only a saw tooth or a triangle wave form (easily generated using a simple oscillator) and a comparator. When the value of the reference signal is more than the modulation wave form, the PWM signal is in the high state, otherwise it is in the low state.

#### **4.2.2. Digital Method:**

The digital method involves incrementing a counter, and comparing the counter value with a pre-loaded register value, or value set by an ADC. They normally use a counter that increments periodically and is reset at the end very period of the PWM. When the counter value is more than the reference value, the PWM output will change state from high to low.

#### **4.2.3. PWM generator chips:**

There are several IC's available which converts a DC level into a PWM output. Many of these are designed for use in switch mode power supplies. Unfortunately, the devices designed for switch mode power supplies do not allow the mark-space ratio to alter over the entire 0 – 100% range. Many limit the maximum to 90% which is effectively limiting the power you can send to the motors.



## **5. SOLDERING**

Soldering is the process of joining two or more electronic parts together by melting solder around the connection. Solder is a metal alloy and when it cools it creates a strong electrical bond between the parts. Even though soldering can create a permanent connection, it can also be reversed using a desoldering tool as described below.

### **5.1. Soldering Iron**

A soldering iron is a hand tool that plugs into a standard 120v AC outlet and heats up in order to melt solder around electrical connections. This is one of the most important tools used in soldering and it can come in a few variations such as pen or gun form. For beginners, it's recommended that you use the pen style soldering iron in the 15W to 30W range. Most soldering irons have interchangeable tips that can be used for different soldering applications. Be very cautious when using any type of soldering iron because it can heat up to 896' F which is extremely hot.

### **5.2. Soldering Station**

A soldering station is a more advanced version of the basic standalone soldering pen. If you are going to be doing a lot of soldering, these are great to have as they offer more flexibility and control. The main benefit of a soldering station is the ability to precisely adjust the temperature of the soldering iron which is great for a range of projects. These stations can also create a safer workspace as some include advanced temperature sensors, alert settings and even password protection for safety.

### **5.3. Soldering Iron Tips**

At the end of most soldering irons is an interchangeable part known as a soldering tip. There are many variations of this tip and they come in a wide variety of shapes and sizes. Each tip is used for a specific purpose and offers a distinct advantage over another. The most common tips you will use in electronics projects are the conical tip and the chisel tip.

**Conical Tip** – Used in precision electronics soldering because of the fine tip. Because of its pointed end, it's able to deliver heat to smaller areas without affecting its surroundings.

**Chisel Tip** – This tip is well-suited to soldering wires or other larger components because of its broad flat tip.

#### **5.4. Brass or Conventional Sponge**

Using a sponge will help to keep the soldering iron tip clean by removing the oxidation that forms. Tips with oxidation will tend to turn black and not accept solder as it did when it was new. You could use a conventional wet sponge but this tends to shorten the lifespan of the tip due to expansion and contraction. Also, a wet sponge will drop the temperature of the tip temporarily when wiped.

#### **5.5. Soldering Iron Stand**

A soldering iron stand is very basic but very useful and handy to have. This stand helps prevent the hot iron tip from coming in contact with flammable materials or causing accidental injury to your hand. Most soldering stations come with this built in and also include a sponge or brass sponge for cleaning the tip.

#### **5.6. Solder**

Solder is a metal alloy material that is melted to create a permanent bond between electrical parts. It comes in both lead and lead-free variations with diameters of .032" and .062" being the most common. Inside the solder core is a material known as flux which helps improve electrical contact and its mechanical strength.

For electronics soldering, the most commonly used type is lead-free rosin core solder. This type of solder is usually made up of a Tin/Copper alloy. You can also use leaded 60/40 (60% tin, 40% lead) rosin core solder but it's becoming less popular due to health concerns. If you do use lead solder, make sure you have proper ventilation and that you wash your hands after use.

## 6. BLOCK DIAGRAM:

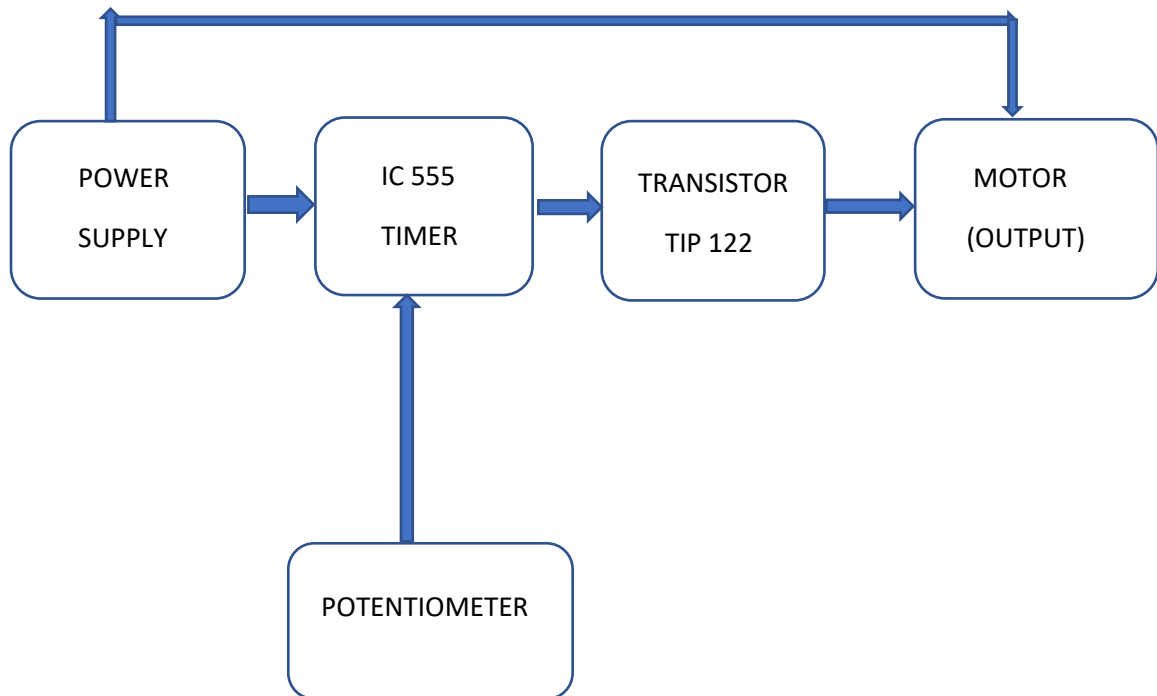

**FIGURE 10: BLOCK DIAGRAM**

## 6.1. BLOCK DIAGRAM DESCRIPTION:

### 6.1.1. POWER SUPPLY:

A **power supply** is an electrical device that supplies electric power to an electrical load. The primary function of a power supply is to convert electric current from a source to the correct voltage, current, and frequency to power the load. As a result, power supplies are sometimes referred to as electric power converters. Some power supplies are separate standalone pieces of equipment, while others are built into the load appliances that they power. All power supplies have a *power input* connection, which receives energy in the form of electric current from a source, and one or more *power output* connections that deliver current to the load.

In this project, we are providing 12V supply to the circuit through 12-0-12 transformer using Capacitors, Voltage Regulator, Resistor, Diode and Led (Indicator).

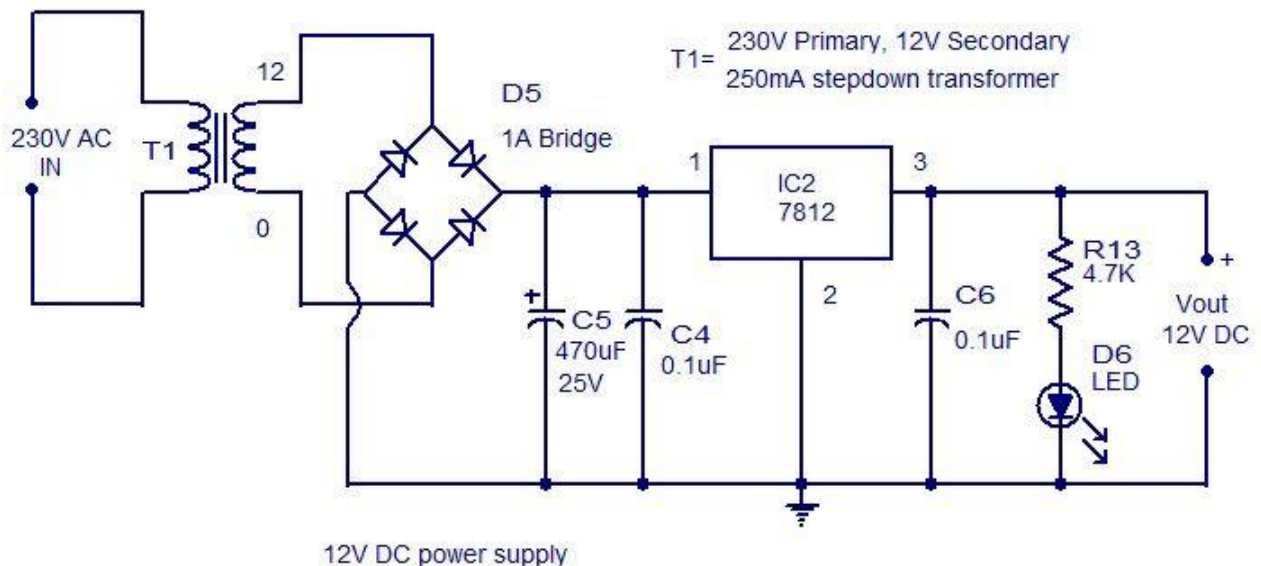

FIGURE 11: 12V POWER SUPPLY

### **6.1.2. IC 555 TIMER:**

The 555 timer IC is an integral part of electronics projects. The 555 timer IC is an integrated circuit (chip) used in a variety of timer, pulse generation, and oscillator applications. The 555 can be used to provide time delays, as an oscillator, and as a flip-flop element. For a 555 timer working as a flip flop or as a multi-vibrator, it has a particular set of configurations.

Some of the major features of the 555 timer would be:

- It operates from a wide range of power ranging from +5 Volts to +18 Volts supply voltage.
- The external components should be selected properly so that the timing intervals can be made into several minutes along with the frequencies exceeding several hundred kilohertz.
- The output of a 555 timer can drive a transistor-transistor logic (TTL) due to its high current output.
- The duty cycle of the timer is adjustable.
- The maximum power dissipation per package is 600 mW and its trigger and reset inputs has logic compatibility.

### 6.1.2.1. PIN DIAGRAM OF IC 555 TIMER

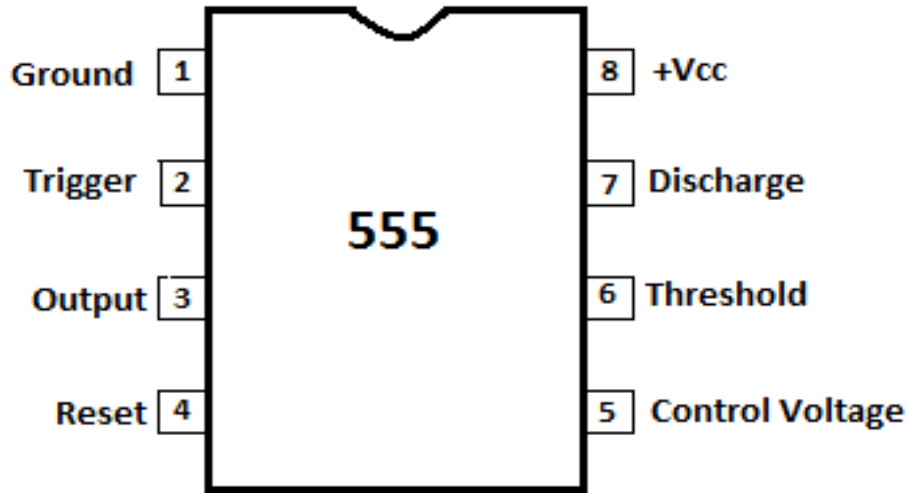

**FIGURE 12: PIN DIAGRAM OF IC 555 TIMER**

PINS	NAME	PURPOSE
1.	GND	Ground reference voltage, low level (0 V)
2.	TRIG	The OUT pin goes high and a timing interval starts when this input falls below 1/2 of CTRL voltage (which is typically 1/3 VCC, CTRL being 2/3 VCC by default if CTRL is left open)
3.	OUT	This output is driven to approximately 1.7 V below +VCC, or to GND.

4.	RESET	A timing interval may be reset by driving this input to GND, but the timing does not begin again until RESET rises above approximately 0.7 volts. Overrides TRIG which overrides THR
5.	CNTL	Provides "control" access to the internal voltage divider (by default, 2/3 VCC)
6.	THR	The timing (OUT high) interval ends when the voltage at THR ("threshold") is greater than that at CTRL (2/3 VCC if CTRL is open)
7.	DIS	Open collector output which may discharge a capacitor between intervals. In phase with output.
8.	V <sub>CC</sub>	Positive supply voltage, which is usually between 3 and 15 V depending on the variation

### 6.1.2.2. 555 TIMER WORKING:

The 555 generally operates in 3 modes:

1. Astable
2. Mono-stable
3. Bi-stable modes.

In this circuit, Astable mode is being used. This means there will be no stable level at the output. So, the output will be swinging between high and low. This character of unstable output is used as a clock or square wave output for many applications.

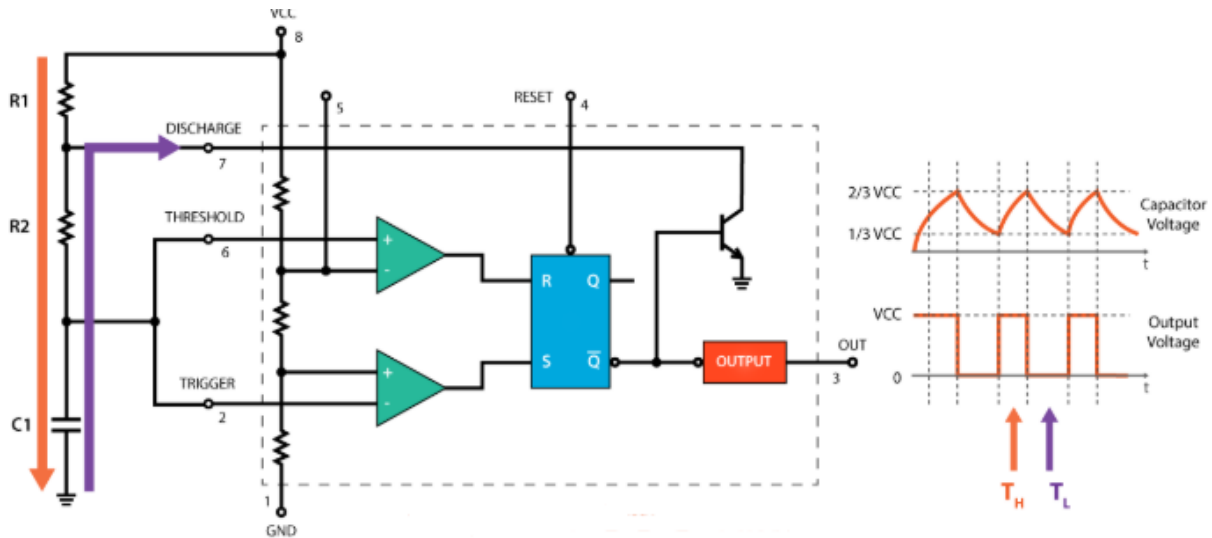

**FIGURE 13: IC 555 TIMER**

### 6.1.3. TRANSISTOR:

In this circuit, we use TIP122 (Darlington NPN) transistor. The **TIP122** is a Darlington pair NPN transistor. It functions like a normal NPN transistor, but since it has a Darlington pair inside it has a good collector current rating of about 5A and a gain of about 1000. It can also withstand about 100V across its collector- Emitter hence can be used to drive heavy loads. The Darlington pair inside this transistor is shown clearly as its internal circuit schematic below

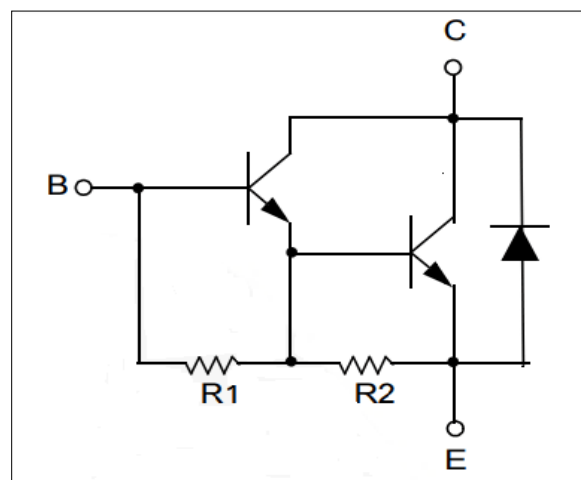

**FIGURE 14: DARLINGTON PAIR NPN TRANSISTOR**



There are two transistors inside this TO-220 package in which the emitter of the first transistor is connected with the base of the second transistor and the collector of both transistors are connected together to form a Darlington pair. This increases the current gain and current rating of this transistor.

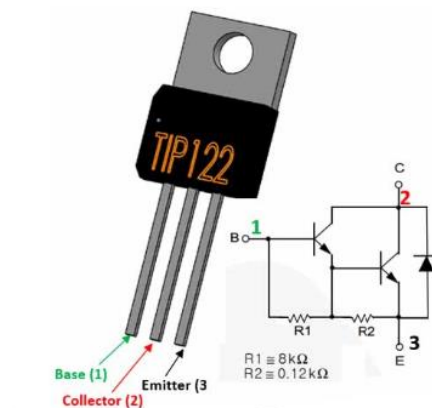

**FIGURE 15: TIP122**

#### **6.1.3.1. APPLICATION:**

- Can be used to switch high current (upto 5A) loads
- Can be used as medium Power switches
- Used where high amplification is needed
- Speed control of Motors
- Inverter and other rectifier circuits

#### **6.1.4. DC MOTOR:**

A **DC motor** is any of a class of rotary electrical machines that converts direct current electrical energy into mechanical energy. The most common types rely on the forces produced by magnetic fields. Nearly all types of DC motors have some internal mechanism,

either electromechanical or electronic, to periodically change the direction of current flow in part of the motor.

In this project, we use 12V DC motor.



**FIGURE 16: 12V DC MOTOR**

### **6.1.5. POTENTIOMETER:**

A potentiometer is a three-terminal resistor with a sliding or rotating contact that forms an adjustable voltage divider . If only two terminals are used, one end and the wiper, it acts as a variable resistor or rheostat.

In this project, we use 100 K $\Omega$  potentiometer.



**FIGURE 17: POTENTIOMETER**

## **7. COMPONENTS:**

### **7.1. COMPONENTS REQUIRED FOR SPEED CONTROL**

1. NE555P TIMER IC
2.  $1\text{K}\Omega$  Resistor  $\times 2$
3.  $100\text{ nF}$  Capacitor  $\times 2$
4. 1N4007 Diode  $\times 3$
5.  $100\text{K}\Omega$  Potentiometer
6. Transistor (Darlington TIP122)
7. 12V Power Supply
8. 12V DC Motor
9. Connecting Wire

### **7.2. COMPONENT LIST OF 12V POWER SUPPLY**

1. Transformer (12-0-12)
2. 1N4007 Diode  $\times 4$
3. Capacitor ( $470\ \mu\text{F}$ , 25V)
4. Capacitor ( $0.1\ \mu\text{F}$ )  $\times 2$
5. Regulator (IC2 7812)
6.  $4.7\ \text{K}\Omega$  Resistor
7. LED bulb

## 8. CIRCUIT DIAGRAM :

### 8.1. CIRCUIT DIAGRAM FOR SPEED CONTROL

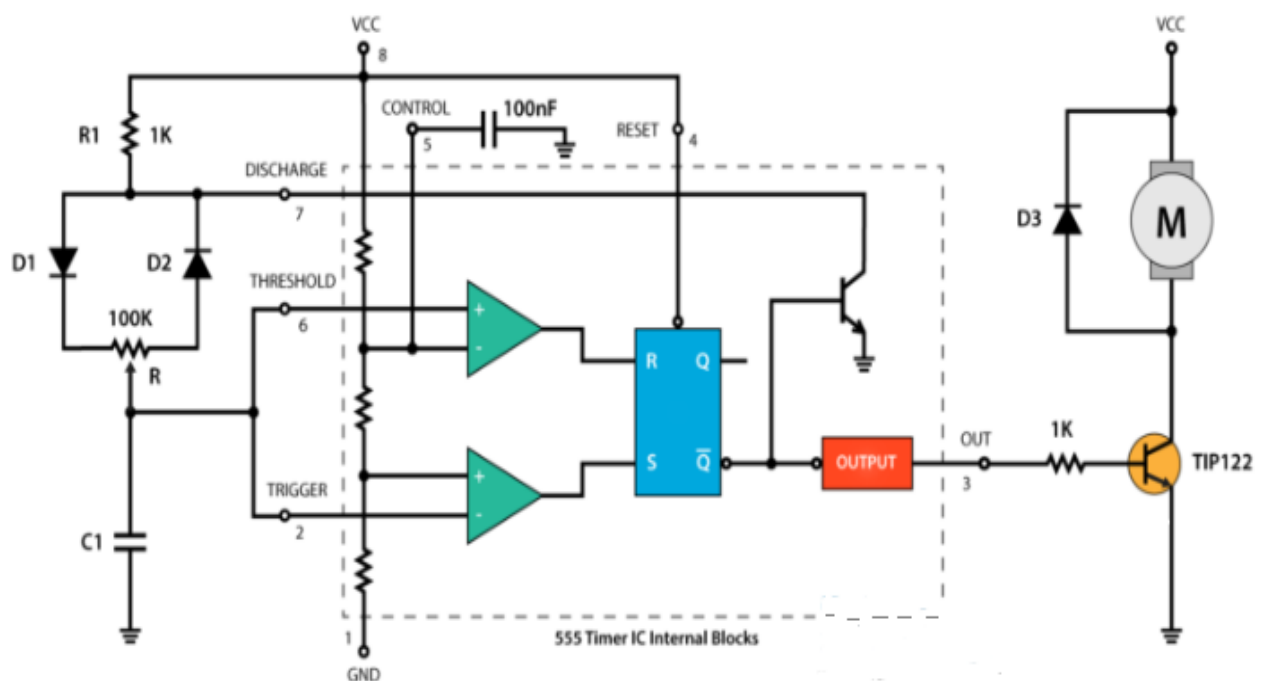

FIGURE 18: CIRCUIT DIAGRAM

### **8.1.1. WORKING OF THE CIRCUIT:**

The 555 Timer is capable of generating PWM signal when set up in an astable mode. In this circuit, the DC motor is operated by a 555 integrated circuit. The IC 555 in this circuit is being operated in astable mode, which produces a continuous HIGH and LOW pulses. In this mode, the 555 IC can be used as a pulse width modulator with a few small adjustments to the circuit. The frequency of operation of the circuit is provided by the passive parameters of resistances and capacitors attached to it.

Here's a basic circuit of the 555 Timer operating in an astable mode and we can notice that the output is HIGH when the capacitor C1 is charging through the resistors R1 and R2. On the other hand, the output of the IC is LOW when the capacitor C1 is discharging but only through the resistor R2. So, we can notice that if we change the values of any of these three components, we will get different ON and OFF times, or different duty cycle of the square wave output signal. An easy and instant way to do this is to replace the R2 resistor with a potentiometer, and additionally add two diodes in the circuit.

In this configuration the ON time will depend on the resistor R1, the left side of the potentiometer and the capacitor C1, while the Off time will depend on the capacitor C1 and the right side of the potentiometer. We can also notice that in this configuration the period of one cycle, thus the frequency, will always be the same, because the total resistance, while charging and discharging, will remain the same.

Usually the R1 resistance is much smaller than the resistance of the potentiometer, for example, 1K compared to 100K of the potentiometer. In that way we have 99% control over the charging and discharging resistance in the circuit. The control pin of the 555 Timer is not used but it's connected to a 100nF capacitor in order to eliminate any external noise from that terminal. The reset, pin number 4, is active low so therefore it is connected to VCC in order to prevent any unwanted reset of the output.

The output of the 555 timers can sink or source a current of 200mA to the load. So, if the motor that we want to control exceeds this rating we need to use a transistor or a MOSFET for driving the motor. In this circuit, I used a (TIP122) Darlington transistor which can handle a current up to 5A.

## 8.2. CIRCUIT DIAGRAM FOR 12V POWER SUPPLY

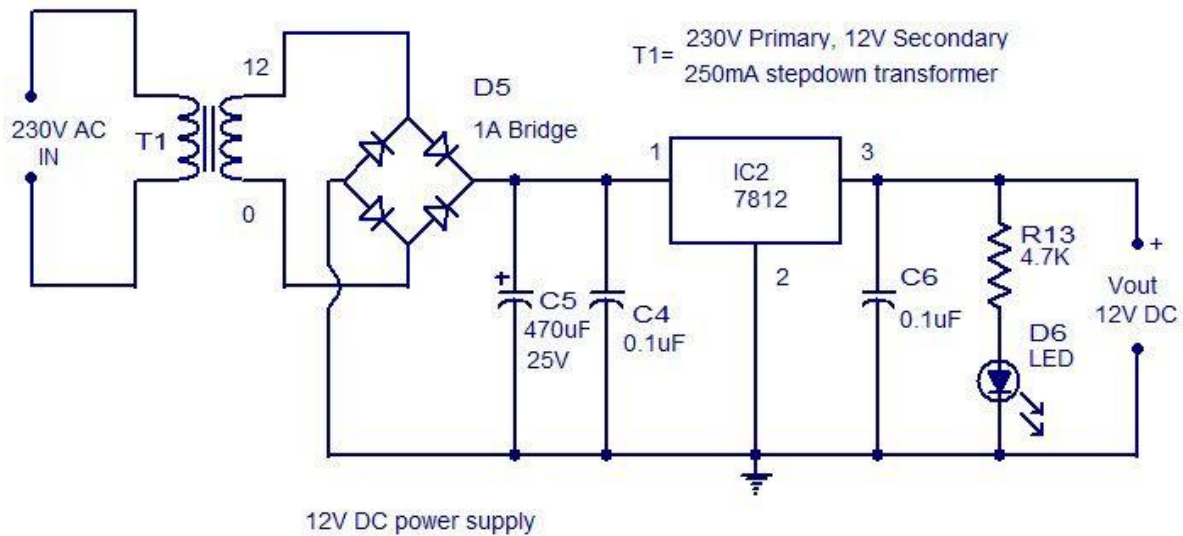

FIGURE 19: CIRCUIT DIAGRAM FOR 12V SUPPLY

### 8.2.1. WORKING OF THE CIRCUIT:

The objective of this project is to convert 220V AC supply in to +12V and -12v DC supply, that is why it is named Dual Power Supply as we get positive and negative 12v power supply at the same time.

This can be achieved in simple three steps:

1. Firstly, 220V AC is converted into 12V AC by using simple step-down (220V/12V) transformer.
2. Secondly, output of this transformer is given to the rectifier circuit, which will convert the ac supply into dc supply. The output of the rectifier circuit that is DC contains the ripples in the output voltage. To filter out these ripples, capacitor of 470 uf and 0.1uf.

3. Lastly, the output of the capacitor that is pure DC is given to voltage regulator IC 7812 which will regulate the output voltage at 12V and -12V DC, despite the change in input voltage.

#### **8.2.1.1. Converting 220v AC into 12v AC using Step Down Transformer**

The primary terminals of the centre tapped transformer is connected with household supply (220V *ac*, 50Hz) and output is taken from secondary terminals of the transformer. The centre tapped describes the voltage output of a center tapped transformer. For example: A 24V centre tapped transformer will measure 24V *ac* across the outer two taps (winding as a whole), and 12V *ac* from each outer tap to the center-tap (half winding). These two 12V *ac* supplies are 180 degrees out of phase with each other, thus making it easy to derive positive and negative 12 volt *dc* power supplies from them. The advantage of using a centre tapped transformer is we can get the both +12V and -12V *DC* supply using only one transformer.

#### **8.2.1.2. Converting 12v AC into 12v DC using Full Bridge Rectifier**

The outer two terminals of the centre tapped transformer are connected to the bridge rectifier circuit. Rectifier circuit is a converter, which converts *ac* supply in to *dc* supply. It is generally made up of diode switches as shown in Circuit Diagram.

To convert *ac* into *dc*, we can make two types of rectifiers, one is half bridge rectifier and second is full bridge rectifier. In half bridge rectifier, output voltage is half of the input voltage. For example, if input voltage is 24V, then output *dc* voltage is 12V and number of diode used in this type of rectifier is 2. In full bridge rectifier, number of diodes is 4 and it is connected as shown in figure and output voltage is same as the input voltage.

Here, full bridge rectifier is used. So, number of diodes are 4 and input voltage (24V *ac*) and output voltage is also 24V *dc* with ripples in it.

For, full bridge rectifier output voltage,

$$V_{DC} = 2V_m / \Pi \text{ where, } V_m = \text{peak value of ac supply voltage and } \Pi \text{ is } \Pi$$

The waveform of input and output voltage of full bridge rectifier is as shown below.

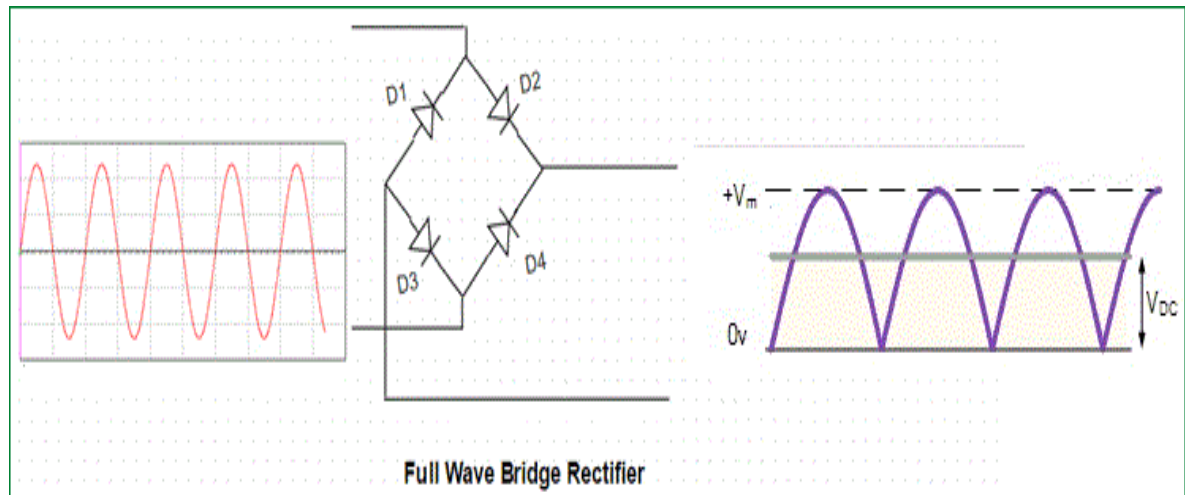

**FIGURE 20: FULL WAVE BRIDGE RECTIFIER WITH INPUT AND OUTPUT WAVEFORM**

In this Dual Power Supply Circuit, Diode bridge rectifier is made up of 6A four power diodes. Rating of this diode is 6A and 400V. It is not necessary to use this much of high current capacity diode but because of safety and flexibility purpose, high current capacity diode is used. Generally, because of surges in current, it is possible to damage the diode, if we used low ampere rating diode.

The output of rectifier is not pure *dc*, but it contains ripples in it.

INPUT: 12V *ac*

OUTPUT: 24V *peak* (with ripples)

### **8.2.1.3. Filter the Ripples from the output:**

24V *dc* output which contains peak to peak ripples can't be connected directly to the load. So, to remove ripples from the supply, filter capacitors are used. Now, two filter capacitor of rating 470uF and 0.1uF are used as shown in circuit diagram. The connection of both capacitors is such that the common terminal of the capacitors is connected directly to the centre terminal of the centre tapped transformer. Now, this capacitor will get charged upto



12V *dc* as both are connected with the common terminal of a transformer. Furthermore, the capacitors will remove the ripples from the *dc* supply and give a pure *dc* output. But, the output of both the capacitors are not regulated. So, to make the supply regulated, output of the capacitors is given to the voltage regulator ICs which is explained in next step.

INPUT: 12V *dc* (with ripples, not pure)

OUTPUT: Voltage across capacitor  $C_1 = 12V$  *dc* (pure *dc*, but not regulated)

Voltage across capacitor  $C_2 = 12V$  *dc* (pure *dc*, but not regulated)

#### **8.2.1.4. Regulate the 12v DC Power Supply**

The next important thing is to regulate the output voltage of the capacitors which will otherwise be varying as per the input voltage change. For that depending upon the output voltage requirement, regulator ICs are used. If we need the output voltage +12V then IC 7812 is used. If required output voltage is +5V, then 7805 IC is used. Last two digits of the IC gives output voltage rating. Third last digit shows voltage is positive or negative. For positive voltage (8) and for negative voltage (9) number is used. So IC7812 is used for +12v regulation and IC7912 is used for -12v voltage regulation.

Now connection of two ICs are done as shown in circuit diagram. The ground terminal of both ICs are connected with the centre tap terminal of the transformer in order to create a reference. Now, the output voltages are measured between the output terminal and ground terminal for both ICs.

INPUT: 12V *dc* (pure *dc* but not regulated)

OUTPUT: +12V *dc* between output terminal of 7812 and Ground (pure *dc* and regulated)

-12V *dc* between output terminal of 7912 and Ground (pure *dc* and regulated)

## 9. HARDWARE MODEL:

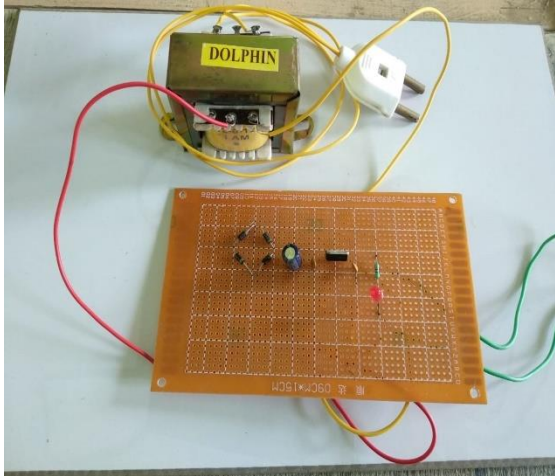

**FIGURE 21: 12V SUPPLY CIRCUIT**

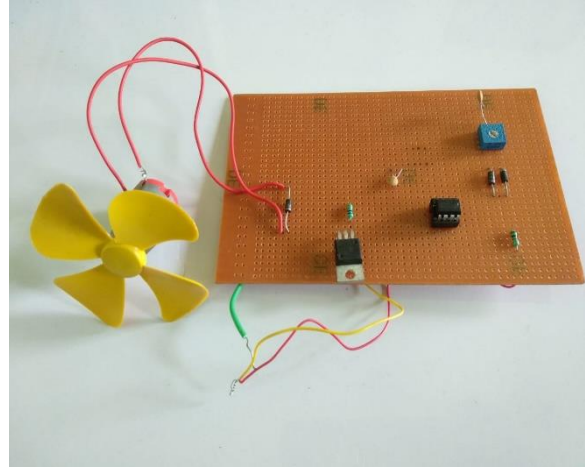

**FIGURE 22: CIRCUIT FOR SPEED CONTROL**

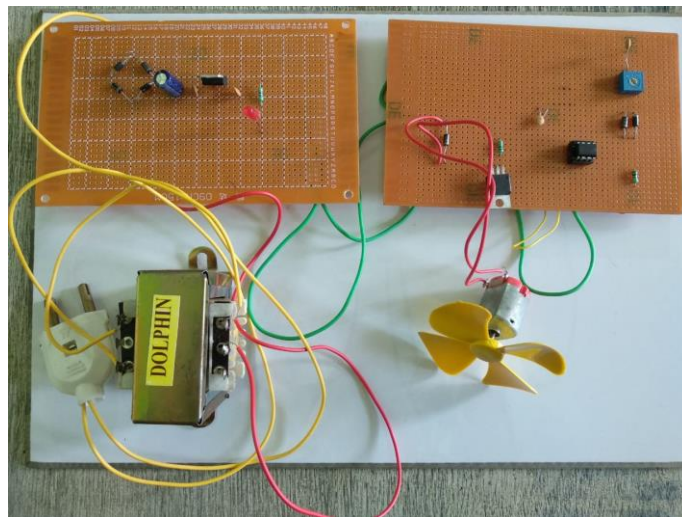

**FIGURE 23: COMPLETE CIRCUIT**

## **10. RESULT AND DISCUSSION:**

By varying the ohmic pot we have done the speed control DC shunt motor by means of PWM method for triggering the base of controlled device called IGBT. We found out that this is very cheap and efficient speed control method where all components give reliable operation and we have checked it experimentally where the efficiency of rheostatic method is better than the PWM control method.

Figure 4 shows the pulses at different duty cycles. The pulse with higher duty cycle turns 'ON' at longer time than that of lower duty cycle. The duty cycle,  $d$  is governed by equation

$$d = t_{on}/T$$

where  $T$  is the duration of one period and  $t_{on}$  is the 'ON' time. The ratio of ON to OFF time is called as duty cycle which determines the speed of the motor. The desired speed can be obtained by changing the duty cycle. The PWM pulse is used to control duty cycle of DC motor drive. Power is supplied to the motor in square wave of constant voltage but varying pulse-width or duty cycle. Duty cycle refers to the percentage of one cycle during which duty cycle of a continuous train of pulses. Since the frequency is held constant while the on-off time is varied, the duty cycle of PWM is determined by the pulse width. Thus, the power increases duty cycle in PWM. The PWM ON period at 60 % of duty cycle is higher than at 40 % duty cycle. This contributes to higher motor speed at 60 % duty cycle compared to 40 % duty cycle. Figure 5 shows the pulses at switching frequency of 500 Hz and 1500 Hz. The frequency of operation,  $f$  is defined as

$$f = 1/(t_{on} + t_{off}) = 1/T$$

Where  $t_{on}$  is the ON time of the PWM pulse,  $t_{off}$  is the 'OFF' time in which the value of PWM pulse is at zero level and  $T$  is the total time period of one duty cycle. Higher switching frequency increases the output voltage.

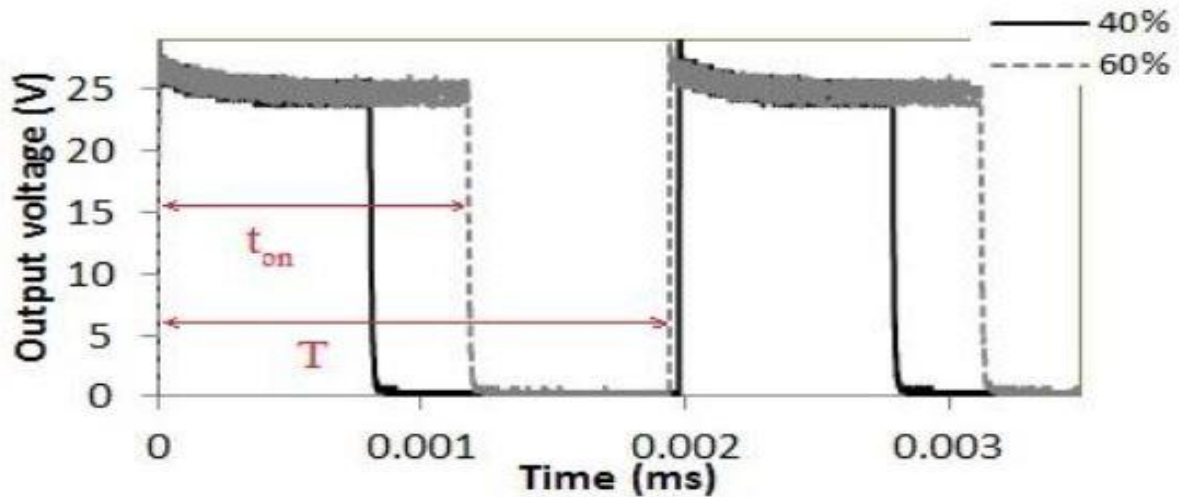

**Figure 24: Pulse at different duty cycle.**

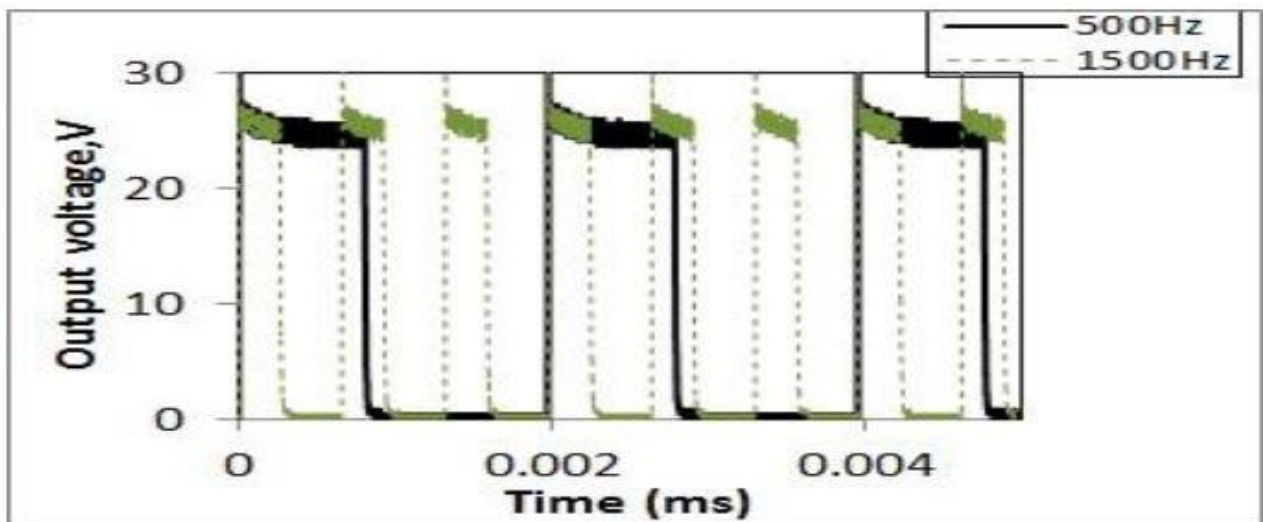
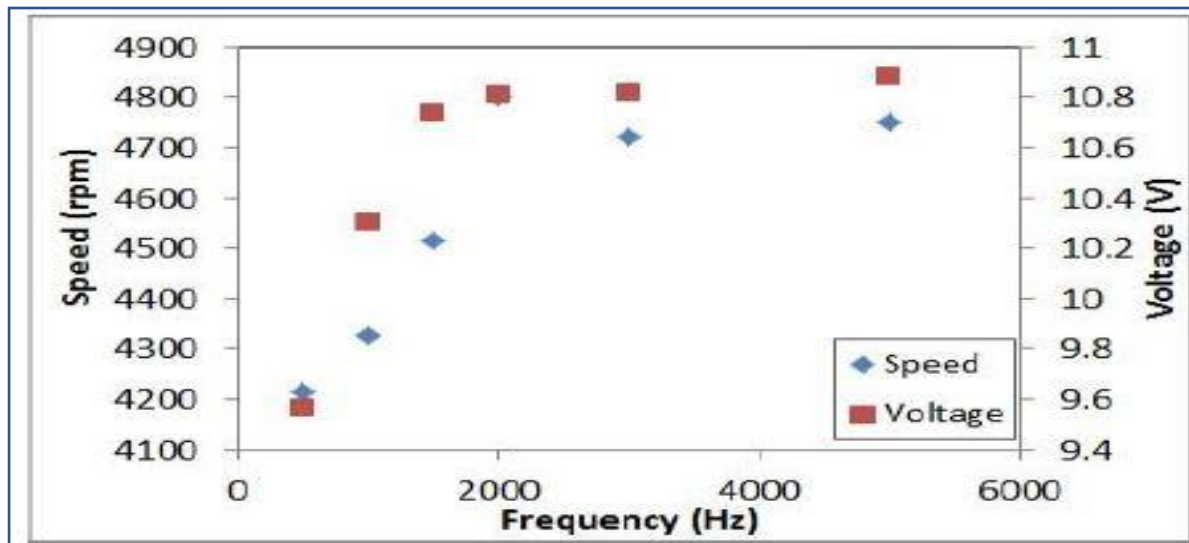

**Figure 25: Pulse at different frequencies.**

Figure 26 shows the motor voltage and speed at different frequencies. The voltage increases steeply from 9.56 V to 10.74 V as the frequency is increased from 500 Hz to 1500 Hz. However, the voltage increases gradually as the frequency is beyond 2000 Hz. This is due to the higher loss at higher frequency (Obed, 2011). It is obvious that the speed increases with increasing of switching frequency. For instance, the speed increases from 4213 to 4722 RPM as the frequency is increased from 500 Hz to 3000 Hz. The average output voltage is governed by

$$V_{av} = (t_{on}/T) * V_m$$

where,  $t_{on}$  is the ON period of PWM pulse,  $T$  is the total time period of the one duty cycle and  $V_{in}$  is the input voltage.



**Figure 26: Motor speed and voltage at different PWM frequency**

Figure 27 shows the motor speed and voltage at different duty cycle for the configuration shown in figure 24. The duty cycle was set from 20 % to 99 %. When the duty cycle is increased the motor speed is also increased. At 20 % duty cycle, the motor speed is 2332 RPM and the converter output voltage is 5.4 V. As the duty cycle increased to 40 %, the motor speed is 2470 RPM and the converter output voltage is 5.82 V. The motor speed and converter output voltage increasing as the duty cycle increases to 60% and 80 %. The maximum speed of 2892 RPM and the maximum voltage were achieved at 99 % duty cycle. This shows that the speed increases as the duty cycle increases.

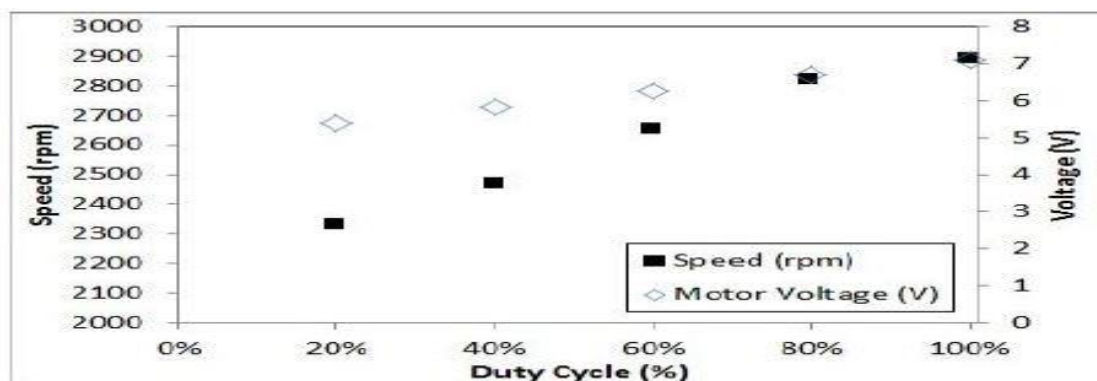

**Figure 27: Motor speed and voltage at different duty cycle**

## **11. CONCLUSION:**

The dc motor speed is controlled by using power electronic device and the PWM is used which to control the speed of dc motor. The speed pulse train will be based on required input speed. This circuit is useful to operate the dc motors at required speed with very low losses and low cost. The circuit response time is fast. Hence high reliability can be achieved. The designed circuit was tested for various speed inputs satisfactorily. The method already employed in traction system and has a good scope ahead.

## **12. FUTURE SCOPE:**

1. DC motor plays a significant role in modern industries. They are widely used in industry because of its low cost, less complex control structure and wide range of speed and torque so better future of this project.

2. In this project we are used pulse width modulation technique, it is a modern technology in solid state field and it provide smooth speed control of motor.

3. Now a day PWM technique are using in fuzzy logic control system, so PWM method is very efficient and reliable method to control the speed of motor so it future is also bright in the modern era with fuzzy logic.

## **APPENDIX:**

<b>S.No.</b>	<b>Components</b>	<b>SPECIFICATION</b>	<b>Quantity</b>	<b>Purpose</b>
1	IC 555 TIMER	-	1	The 555 can be used to provide time delays, as an oscillator, and as a flip-flop element.
2	RESISTOR	1k $\Omega$	2	resistor is used to limit the current.
		4.7k $\Omega$	1	
3	CAPACITOR	470 $\mu$ F,25V	1	capacitors are used in power supplies where they smooth the output of a full or half wave rectifier.
		0.1 $\mu$ F	2	
		100nF	2	
4	1N4007 DIODE	1A,3W Reverse Current- 5 $\mu$ A	7	A rectifier diode is used as a one-way check valve. Since these diodes only allow electrical current to flow in one direction, they are used to convert AC power into DC power.
5	POTENTIOMETER	100k $\Omega$	1	The Potentiometer is an electric instrument that used to measure the EMF (electro motive force) of a given cell, the internal resistance of a cell. And also, it is used to compare EMFs of different cells. It can also use as a variable resistor



				in most of the applications.
6	TRANSISTOR	5.0A,60-100V,65W	1	A transistor is a semiconductor device used to amplify or switch electronic signals and electrical power.
7	DC MOTOR	12V	1	A DC motor is any of a class of rotary electrical machines that converts direct current electrical energy into mechanical energy.
8	TRANSFORMER	12-0-12V	1	Transformers (sometimes called "voltage transformers") are devices used in electrical circuits to change the voltage of electricity flowing in the circuit.  Transformers can be used either to increase the voltage (called "stepping up") or decrease the voltage ("step down").
9	IC2 7812	-	1	IC 7812 and 7912 are used for the purpose of voltage regulation in which the former is a positive 12V regulator

				and later is a negative 12V regulator
10	LED BULB	3V,50mA	1	A light-emitting diode (LED) is a semiconductor light source that emits light when current flows through it. Electrons in the semiconductor recombine with electron holes, releasing energy in the form of photons.

## **REFERENCES:**

- [1]. Arvind, S.K., Arun, T.A., Madhukar, T.S., &Deka, J., (2014). Speed Control of DC Motor using PIC 16F877A Microcontroller. *Multidisciplinary Journal of Research in Engineering and Technology*, 1(2), 223-234.
- [2]. Bansal, U. K.&Narvey, R. (2013). Speed control of DC motor using fuzzy PID controller. *Advance in Electronic and Electric Engineering*. 3(9) , 1209-1220.
- [3]. Bakibillah,A.S.M.,Rahman, N., & Zaman, U. A. (2014).Microcontroller based Closed Loop Speed Control of DC Motor using PWM Technique.*International Journal of Computer Applications*, 108(14), 15-18.
- [4]. Chauhan., J. S.& Semwal, S. (2013). Microcontroller Based Speed Control of DC Geared Motor through RS-232 Interface with PC. *International Journal of Engineering Research and Applications*, 3(1), 778-783.
- [5]. Gupta, R., Lamba, & Padhee, (2012). Thyristor Based Speed Control Techniques of DC Motor: A Comparative Analysis. *International Journal of Scientific and Research Publications*, 2 (6). 1-6.
- [6]. Kapil, P.N., &Patel, K. (2015).Simulation Of PWM Controller Based DC Motor. *International Journal of Current Engineering and Scientific Research*, 2(5), 65-68.
- [7]. Obed, A.A., &Basheer, A.(2011).Effect of duty cycle and chopper frequency of PWM DC-DCconverter drive on performance characteristics of DC motor.The fourth International scientific Conference of Salahaddi University-Erbil, 87-92.
- [8]. Shrivastava, S., Rawat, J.&Agrawal, A.(2012).Controlling DC Motor using Microcontroller (PIC16F72) with PWM.*International Journal of Engineering Research*, 1(2), 45-47.
- [9].Gopal K Dubey “Fundamentals of Electric Drives” Narosa Publishing House New Delhi, 1989.
- [10].Muhammad H. Rashid, “Power Electronics Circuits, Devices, and Applications,” Prentice Hall, 3rd edition, 2003.
- [11]. Kumara MKSC, Dayananda PRD, Gunatillaka MDPR, Jayawickrama SS, “PC based speed controlling of a dc motor”, A final year report University of Moratuwa Illinias USA, 2001102.
- [12]. J Nicolai and T Castagnet , “A Flexible Micro controller Based Chopper Driving a Permanent Magnet DC Motor”, *The European Power Electronics*

Application. 1993

[13]. A Khoei Kh. Hadidi, "MicroProcessor Based Closed- Loop Speed Control System for DC Motor Using Power *MOSFET*", 3rd IEEE international conference on Electronics, Circuits and Systems( 1996) vol.2, pp.1247-1250.