

# Substation Monitoring & Control System

*A Project report submitted in partial fulfillment  
of the requirements for the degree of B. Tech in Electrical Engineering*

*by*

*Sourav Gorai*

*EE2017/L05*

*11701617004*

*Nitish Kumar Sah*

*EE2016/020*

*11701616049*

*Pritam Kharadhara*

*EE2016/032*

*11701616046*

*Under the supervision of—*

*Mr. Subhasis Bandopadhyay*

Assistant Professor  
Department of Electrical Engineering



श्रमम् बिना न किमपि साध्यम्

Department of Electrical Engineering  
**RCC INSTITUTE OF INFORMATION TECHNOLOGY**  
CANAL SOUTH ROAD, BELIAGHATA, KOLKATA – 700015, WEST BENGAL  
Maulana Abul Kalam Azad University of Technology (MAKAUT)



Department of Electrical Engineering  
**RCC INSTITUTE OF INFORMATION TECHNOLOGY**  
CANAL SOUTH ROAD, BELIAGHATA, KOLKATA – 700015, WESTBENGAL  
PHONE: 033-2323-2463-154, FAX:033-2323-4668

Email: hodeercciit@gmail.com, Website: <http://www.rcciit.org/academic/ee.aspx>

# CERTIFICATE

## To whom it may concern

This is to certify that the project work entitled **Substation Monitoring & Control System** is the bonafide work carried out by **Sourav Gorai (11701617004)**, **Nitish Kumar Sah (11701616049)**, **Pritam Kharadhara (11701616046)** the students of B. Tech in the Department of Electrical Engineering, RCC Institute of Information Technology (RCCIIT), Canal South Road, Beliaghata, Kolkata-700015, affiliated to Maulana Abul Kalam Azad University of Technology (MAKAUT), West Bengal, India, during the academic year 2019-20, in partial fulfillment of the requirements for the degree of Bachelor of Technology in Electrical Engineering and that this project has not submitted previously for the award of any other degree, diploma and fellowship.

---

(Mr. Subhasis Bandopadhyay)  
Assistant Professor  
Department of Electrical Engineering  
RCC Institute of Information Technology

Countersigned by

---

(Dr. Debasish Mondal)  
HOD, Electrical Engineering Dept.  
RCC Institute of Information Technology

---

(External Examiner)

# ACKNOWLEDGEMENT

It is our great fortune that we have got opportunity to carry out this project work under the supervision of **MR. SUBHASIS BANDOPADHYAY** in the Department of Electrical Engineering, RCC Institute of Information Technology (**RCCIIT**), Canal South Road, Beliaghata, Kolkata-700015, affiliated to Maulana Abul Kalam Azad University of Technology (**MAKAUT**), West Bengal, India. We express our sincere thanks and deepest sense of gratitude to our guide for his constant support, unparalleled guidance and limitless encouragement.

We would also like to convey our gratitude to all the faculty members and staffs of the Department of Electrical Engineering, RCCIIT for their whole hearted cooperation to make this work turn into reality.

We are very thankful to our Department and to the authority of RCCIIT for providing all kinds of infrastructural facility towards the research work.

Thanks to the fellow members of our group for working as a team---

**Sourav Gorai (11701617004)**

**Nitish Kumar Sah (11701616049)**

**Pritam Kharadhara (11701616046)**

To,  
The Head of the Department,  
Electrical Engineering Department,  
RCC Institute of Electrical Engineering,  
Canal South Road, Beliaghata, Kolkata-700015

Respected Sir,

In accordance with the requirements of the degree of Bachelor of Technology in the Department of Electrical Engineering, RCC Institute of Information Technology, We present the following thesis entitled "Substation Monitoring and Control System". This work was performed under the valuable guidance of Mr. Subhasis Bandopadhyay, Assistant Professor in the Dept. of Electrical Engineering.

We declare that the thesis submitted is our own, expected as acknowledge in the test and reference and has not been previously submitted for a degree in any other Institution.

Yours Sincerely,

**Sourav Gorai (11701617004)**

**Nitish Kumar Sah (11701616049)**

**Pritam Kharadhara (11701616046)**

# CONTENTS

<u>Topics</u>	<u>Page</u>	
List of Figures	i	
List of Tables	ii	
Abbreviations & Acronyms	iii	
Abstract	iv	
<b>Chapter – 1</b>	<b>Introduction</b>	<b>1-5</b>
1.1	Introduction	2
1.2	Brief Overview of the Project	2
1.3	Necessity of the Project	2
1.4	Objective of the Project	3
1.5	Benefits of the Project	4
1.6	Organisation of Thesis	5
<b>Chapter – 2</b>	<b>Literature Review</b>	<b>6-8</b>
<b>Chapter – 3</b>	<b>Intelligent Devices &amp; Systems</b>	<b>9-18</b>
3.1	Embedded Systems	10
3.2	Delineation about IoT	11
3.3	An Overview of the IED	15
3.4	Wireless Sensor Network	18
<b>Chapter – 4</b>	<b>Theoretical Aspects</b>	<b>19-27</b>
4.1	Electrical Substation	20
4.2	Maintenance of the Substation	24
4.3	Monitoring Systems	25
<b>Chapter – 5</b>	<b>Methodology</b>	<b>28-33</b>
5.1	What we want to do?	29
5.2	Logic & Operation	30
5.3	Main Features of the Project	31
5.4	Components Required	32
5.5	Cost Estimation	33
<b>Chapter – 6</b>	<b>Implementation</b>	<b>34-59</b>
6.1	Project Layout	35
6.2	Components	35
6.3	Diagrams	58
<b>Chapter – 7</b>	<b>Conclusion &amp; Future work</b>	<b>60-63</b>
7.1	Advantages of the Project	61
7.2	Achievements of the Project	62
7.3	Conclusion	62
7.4	Future Scope	63

**REFERENCES**

64-65

**APPENDIX A**

**SOFTWARE CODE**

66-68

# List of Figures

No. of Figures	Name of Figures	Page
3.1	Technology Roadmap of IoT	13
3.2	IED based Protective Relay	15
3.3	Connection to a protection-class and instrument current transformer	16
3.4	Self-monitoring and external circuit monitoring	17
4.1	A Typical Substation	20
4.2	Step-up substation	21
4.3	Step-down substation	21
4.4	Underground Substation	22
4.5	Instrument Transformer	22
4.6	Current Transformer	23
4.7	Potential Transformer	23
4.8	Busbars	23
4.9	Lighting Arrester	23
4.10	Circuit Breaker	23
6.1	Project Layout	35
6.2	Arduino Uno Board	35
6.3	Full Schematics of Arduino Uno	36
6.4	Block Diagram of PSPU	38
6.5	Circuit Diagram of PSPU	38
6.6	Transformer Basics	39
6.7	Bridge Rectifier	39
6.8	Functionality of Filter Circuit	39
6.9	Functionality of Shunt Capacitor Filter	40
6.10	Schematics of LM7805	41
6.11	Connection Diagram of LM7805	41
6.12	ACS712 Current Sensor	42
6.13	Pin Diagram of ACS712	43
6.14	Typical Application Pin-out of ACS712	43
6.15	Typical Application Connection of ACS712	43
6.16	Connection Diagram of Interfacing of ACS712 with Arduino Uno	45
6.17	Image of ACS712 being Interfaced with Arduino Uno	45
6.18	ZMPT101B Voltage Sensor Module	46
6.19	ZMPT101B Voltage Transformer	46
6.20	ZMPT101B with being Interfaced with Arduino Uno	48
6.21	ZMPT101B with ACS712 being Interfaced with Arduino Uno	48
6.22	Frequency Measurement Circuit with Arduino Uno	49
6.23	Frequency Measurement Result	51
6.24	LM35 Temperature Sensor	51
6.25	Pin Diagram of LM 35 Temperature Sensor	52
6.26	Interfacing of LM35 Sensor with Arduino Uno	52
6.27	Relay Module	53
6.28	Single Cube Relay	53
6.29	Two Channel Relay Module Pinout	54
6.30	Interfacing of Relay Module with Arduino	54

## List of Tables

<b>No. of Tables</b>	<b>Name of Tables</b>	<b>Page</b>
5.1	Components Required	32
5.2	Cost Estimation	33
6.1	Technical Specification of Arduino Uno	36
6.2	Pin Details of LM7805	46
6.3	Pin Details of ACS712	43
6.4	Technical Specification of ZMPT101B	47
6.5	Pin Details of LM 35 Sensor	52
6.6	Pin Details of 16*2 LCD Display	56



# Abbreviations & Acronyms

<b>AC</b>	Alternating Current
<b>AMI</b>	Advanced Metering Infrastructure
<b>BLE</b>	Bluetooth Low Energy
<b>CB</b>	Circuit Breaker
<b>CBM</b>	Maintenance Based on Condition
<b>CT</b>	Current Transformer
<b>DC</b>	Direct Current
<b>EHV</b>	Extra High Voltage
<b>GSE</b>	Generic Substation Events
<b>GUI</b>	Graphical User Interface
<b>IC</b>	Integrated Circuit
<b>ICSP</b>	In Circuit Serial Programming
<b>IDE</b>	Integrated Development Environment
<b>IEC</b>	International Electrotechnical Commission
<b>IED</b>	Intelligent Electronic Devices
<b>NC</b>	Normally Close
<b>NFC</b>	Near Field Communication
<b>NO</b>	Normally Open
<b>PLC</b>	Programmable Logic Controller
<b>PLC</b>	Power Line Communication
<b>PSPU</b>	Power Supply Processing Unit
<b>PT</b>	Potential Transformer
<b>PWM</b>	Pulse Width Modulation
<b>RCM</b>	Reliability Centered Maintenance
<b>RFID</b>	Radio Frequency Identification
<b>RMS</b>	Root Mean Square
<b>TBM</b>	Maintenance based on Time
<b>SoC</b>	System on Chip
<b>SPDT</b>	Single Pole Double Throw
<b>TBM</b>	Maintenance based on Time
<b>WSN</b>	Wireless Sensor Networks
<b>μC</b>	Micro Controller

# **ABSTRACT**

As complexity of distribution network has grown, automation of substation has become a need of every utility company. To Improve the quality of power it is necessary to be familiar with what sort of constraint has occurred. Additionally, if there is any inadequacy in the protection, monitoring and control of a power system. Therefore, it necessitates a monitoring system that will be able to automatically detect, monitor, and classify the existing constraints on electrical lines.

The purpose of this project is to acquire the remote electrical parameters like voltage, current and frequency and send these real time values over network along with temperature at power station. This project is also designed to protect the electrical circuitry by operating a relay. This relay gets activated whenever the electrical parameters exceeds the predefined values. This system can automatically update the real time electrical parameters periodically (based on time settings). This system can be designed to send alerts whenever the relay trips or whenever the voltage or current exceeds the predefined limits. This project makes use of a microcontroller, as this is a prototype of the proposed project, for demonstration purpose we have used Arduino Uno here. The controller can efficiently communicate with the different sensors being used

When we give supply to our prototype all the sensors start sensing the current, voltage, frequency and temperature and update all the real time values to the server as well as shows on the display. It compares all the real time values with the pre-defined values, if any of the values exceeds pre-defined values it sends a fault alert to the relay and buzzer as well as update it on the display. If the fault exists for the pre-set time then relay isolates the loads from the rest of the system. In the meantime, comparison goes on as before, if the fault gets cleared relays reconnect the loads with the rest of the system.

# CHAPTER 1

## (INTRODUCTION)

## **1.1 INTRODUCTION**

Electricity is an extremely handy and useful form of energy. It plays an ever-growing role in our modern industrialized society. The electrical power systems are highly non-linear, extremely huge and complex networks. Such electric power systems are unified for economic benefits, increased reliability and operational advantages. They are one of the most significant elements of both national and global infrastructure, and when these systems collapse it leads to major direct and indirect impacts on the economy and national security. A power system consists of components such as generators, lines, transformers, loads, switches and compensators. However, a widely dispersed power sources and loads are the general configuration of modern power systems. Today electricity still suffers from power outages and blackouts due to the lack of automated analysis and poor visibility of the utility over the grid. WSN will give the utility provide the needed view by collecting information from the different sub-systems of the grid. A sensor node will decide information or to slightly delay this notification (whether to immediately notify the sink about this information.). As complexity of distribution network has grown, automation of substation has become a need of every utility company to increase its efficiency and to improve quality of power being delivered.

## **1.2 BRIEF OVERVIEW OF THE PROJECT**

The purpose of this project is to acquire the remote electrical parameters like voltage, current and frequency and send these real time values over network using IoT module along with temperature at power station. This project is also designed to protect the electrical circuitry by operating an SPDT relay. This relay gets activated whenever the electrical parameters exceed the predefined values. The relay can be used to switch off the main electrical supply. User can send commands to the microcontroller to read the remote electrical parameters. This system also can automatically send the real time electrical parameters periodically (based on time settings). This system can be designed to send alerts whenever the relay trips or whenever the voltage or current exceeds the predefined limits. This project makes use of a microcontroller, in this prototype for demonstration purpose we have used Arduino Uno. The controller can efficiently communicate with the different sensors being used. The controller is provided with some internal memory to hold the code. This memory is used to dump some set of assembly instructions into the controller.

## **1.3 NECESSITY OF THE PROJECT**

As complexity of distribution network has grown, automation of substation has become a need of every utility company to increase its efficiency and to improve quality of power being delivered. Today electricity still suffers from power outages and blackouts due to the lack of automated analysis and poor visibility of the utility over the grid. WSN will give the utility provide the needed view by

collecting information from the different sub-systems of the grid. A sensor node will decide information or to slightly delay this notification (whether to immediately notify the sink about this information.). The distance between the generators and load may be in terms of hundreds of miles hence the amount of huge power exchange over long distances has turned out as a result of the lack of quality of the electric power. During the earlier development stages the issues on quality of power were not frequently reported. Demanding the quality of power being delivered at the user side has raised the alarm due to the increase in demand of electricity in the customer side. A huge amount of power is lost during the transportation of the general power which leads to the reduction in the quality of power received at substation. To Improve the quality of power with suffer solution it is necessary to be familiar with what sort of constraint has occurred. Additionally, if there is any inadequacy in the protection, monitoring and control of a power system. The system might become unstable. Therefore, it necessary a monitoring system that is able to automatically detect, monitor, and classify the existing constraints on electrical lines.

#### **1.4 SALIENT OBJECTIVES OF THE PROJECT**

##### **To improve reliability and compatibility**

This is one of the main objectives of our project to improve the reliability of the power being delivered by speedy detection and isolation of the fault and maintaining a constant voltage level, which will make the project utmost reliable and compatible.

##### **Real time monitoring**

As complexity of distribution network has grown, automation of substation has become a need of every utility company to increase its efficiency and to improve quality of service. One of the main objectives of this project of ours is to ensure real time monitoring.

##### **Remote sensing of observant parameters**

Although this project is meant for all the substation equipments but we developed this prototype keeping in mind the transformers which are usually deployed in dispersed locations. Through this project we want to ensure remote sensing all the observant parameters.

##### **To Maintain Continuity of supply**

By keeping track on the real time parameters, we want to maintain the continuity of the supply.

##### **To Reduce labour cost**

One of the main objectives of our project is to reduce the labour cost to some extent which will make the facility more economical.

## 1.5 **BENEFITS OF THE PROJECT**

### **Real time monitoring**

This is one of the main perspectives why we have chosen this project in the first place. In most of the today's facilities lack in this point, because they don't have proper facility to fetch real time data; they usually rely on the periodically collected data that too manually collected. Thereby it is very tough sometimes to judge the actual health of the machine we are monitoring. What has been overcome through this project. Here we are able to monitor the real time data of the machine irrespective of fault.

### **Remote Access**

This is one of the main advantages of this project. All the real time data collected by WSN are being updated to the server, which enables us to get all the real time data at its ease remotely. Which means we do not need to go the control room to physically check the data.

### **Periodical collection of data**

Now a days in most of the power facilities the work personnel responsible for collection of data go to the control room and physically jot down all the data and then after coming back again updates all those to the data sheets which is a lot more time consuming. But through our project all these could be done in a matter of seconds. All the real time data being collected will be stored in a external memory periodically. Although as of now we have not included any sort of extremal memory in our prototype, for demonstration purpose we have used the microcontroller memory only.

### **Error free data**

As we already have discussed by now that data in the power facilities are mostly collected manually, which are error prone. And most importantly we do not get all the data at a single sync because manual collection of data will involve delay to some extent i.e., values of all the machines are not of same time instant, which doesn't matter that much if the facility is smaller, but just imagine the scenario in case of a large power facility where a person need to take hundreds of values there this delay is considerable. Here the data will be error free as we have eliminated any manual involvement in case of data collection.

### **Personalised alert over fault**

By incorporating this project, we can get Personalised alerts over any sort of discrepancies i.e., whenever the electrical parameters exceed the predefined values. We have incorporated relays which acts over and physically isolates the machines where disturbances occur.

### **Reduced hazards**

In larger switchyards there are lot of high voltage equipments. Which are hazardous for the working personnel. Through our project as we can remotely observe and collect all the required data, thereby it reduces hazards.

### **Cost effective**

After incorporating this project, we do not need to deploy person at every place for collection data, this reduction of manual force reduces the labour cost to some extent. The sensors and transducers employed also does not need regular maintenance which in turn reduces the maintenance cost. That means overall labour cost is reduced.

## **1.6 ORGANISATION OF THESIS**

The thesis is organised into five chapters including the chapter of introduction. Each chapter is different from, the other and is described along with the necessary theory to comprehend it.

**Chapter 2** deals with the literature reviews. From this chapter we can see before us who else have worked on this topic and how our work is different and advance from those projects.

**Chapter 3** deals with the required theory to understand what actually intelligent devices and systems are, and how they incorporated through our project. It discussed about IoT, IED and WSN devices and their features.

**Chapter 4** deals with the required theory aspects behind our project. It discusses about all the theory which helped us to establish this project along with all the required theory about all the components we have used here.

**Chapter 5** discusses the methodology of our project which includes all the necessary block diagram, flow diagram and circuit diagram related to our project

**Chapter 6** includes all the updates of the implementation of the project which includes all the information about hardware and software implementation along with result and discussions.

**Chapter 7** deals with all the future scopes related to the project and includes concluding statement of our work

# CHAPTER 2

(LITERATURE REVIEW)



This chapter includes all the literature associated to our work, who so ever have done any work in this field, we have mentioned all of them. Let us take you through all of them: -

Amol Ram Kate, Girish Baban Dongare, Krishana Maroti Janwade, Payal Burande & Narendra P. Zinjad's  
**“Substation Monitoring System”**

This project is aimed to design a system which can monitor and control the substation by using a wireless technology called IOT. An IOT module provides the communication interface. By using IOT module we can update data on web server. In our project we are considering substation parameters, voltage and current, frequency, temp. The project will be designed in such a way that an sensor will be interfaced to the controller. Here the inputs for the ADC are the analog values of voltage, current .In this project microcontroller is connected to IOT module through serially. By varying these two pots microcontroller detects voltage and current frequency, temp fluctuations and sends that particular values to the web server. According to voltage and current fluctuations relays has to be triggered for protecting substation at that time bulb will OFF. A 16x2 LCD is also provided to display the status of the system. This project uses regulated 5V, 500mA power supply. Unregulated 12V DC is used for relay.7805 three terminal voltage regulators is used for voltage regulation. Bridge type full wave rectifier is used to rectify the ac output of secondary of 230/12V step down transformer.

Krupal Dhimar, Mr. Jenish Patel, Mr. Yasin Shaikh, Mr. Anas Musani & Mr. Krishn Patel's  
**“Substation Monitoring and Control Using Microcontroller & GSM”**

The purpose of this project is to acquire the remote electrical parameters like voltage, current and frequency and send these real time values over gsm network using gsm modem/phone along with temperature at power station. User can send commands in the form of sms messages to read the remote electrical parameters. This system also can automatically send the real time electrical parameters periodically (based on time settings) in the form of sms. This system can be designed to send sms alerts whenever the relay trips or whenever the voltage or current exceeds the predefined limits. This project makes use of a microcontroller. The controller can efficiently communicate with the different sensors being used. The controller is provided with some internal memory to hold the code. This memory is used to dump some set of assembly instructions into the controller. And the functioning of the controller is dependent on these assembly instructions. The controller is programmed using embedded c language.

Ghous Buksh Narejo, Shahyan Pervez Bharucha, Danny Zarir Pohwala's  
**“Remote Microcontroller Based Monitoring of Substation and Control System through GSM Modem”**

As complexity of distribution network has grown, automation of substation has become a need of every utility company to increase its efficiency and to improve quality of power being delivered. The proposed project which is GSM cellular network-based controlling of substation will help the utility companies, by ensuring that their local-substation faults are immediately realized and reported to their concerned departments via

GSM, to ensure that duration of power interruption is decreased. The measured parameters will be sending in the form of SMS messages. The microcontroller will interact with the sensors installed at the local substation and perform task as commanded. Electrical parameters like current, voltage will be compared continuously to its rated value will help protect the distribution and power transformer from burning due to overload, short circuit fault, over voltages and surges. Under such conditions, entire unit is shut down via the control section comprising of relays sensing it, and immediately turning the circuit breaker off. SMS alerts can also be generated to indicate this. The use of GSM makes the substation intelligent in the sense that it is able to transmit alerts and information and receive commands. This enables to reduce labour cost at substation and saves time. Thus the monitoring and working efficiency of the sub-station will drastically increase.

Dumitru SACERDOȚIANU, Florica LĂZĂRESCU, Iulian HUREZEANU, Marcel NICOLA, Ion PURCARU, Anca ALBIȚA's **"Contribution to monitoring the condition of substations"**

By promoting modern and competitive techniques and equipment for online monitoring and diagnosis, it is possible to track natural or accidental degradation over time. If identified in time and remedied, it will not generate serious events which may be sources of extremely costly damage for electric power suppliers and consumers. At the same time it is possible to extend the life of the equipment, optimize the maintenance program and reduce the outages and expenses for planned repairs. The paper presents an analysis of the vital parameters of MV, LV transformer substations and proposes a system for monitoring their working condition. The main objective of the paper is to present a modular system for transformer substation monitoring in order to increase the quality of electric power supply for consumers and reduce the costs of equipment overhaul and maintenance. Based on the considerations on the transformation substation condition monitoring, the paper presents achieved of such a monitoring system, which can be integrated into SCADA.

Dirman Hanafi, Mohamed Najib Ribuan, Ignatius Agung Wibowo, Hairulazwan Hashim, Muhamad Izzuddin Ismail's **"Simulation Of Substation Integrated Monitoring System Using LabVIEW"**

This paper presents the new integrated monitoring system for high voltage electric power substation system. The substation has a crucial function to maintain the reliability and to keep the quality of an electric power transmission system. On the other hand, the exposure to high voltage environment may also be able to cause risk to human health. Therefore, an integrated monitoring system is crucial to be implemented for easy monitoring and controlling the substation whil minimizing interaction of human to the substation devices. All the substation devices conditions are displayed integratedly in Graphical User Interface (GUI) developed using LabVIEW software. The developed display contains several windows and said window display. As a result, the parameters of the substation devices such as: frequency, voltage, load impedance, reluctance, oil level, temperature, cooling condition, power and protection system are successful displayed and monitored.

# **CHAPTER 3**

## **(INTELLIGENT DEVICES & SYSTEMS)**

## **3.1 EMBEDDED SYSTEMS**

### **3.1.1 Introduction**

An embedded system is a combination of computer hardware and software, either fixed in capability or programmable, designed for a specific function or functions within a larger system. Industrial machines, agricultural and process industry devices, automobiles, medical equipment, cameras, household appliances, airplanes, vending machines and toys, as well as mobile devices, are possible locations for an embedded system.

Embedded systems are computing systems, but they can range from having no user interface (UI) for example, on devices in which the system is designed to perform a single task to complex graphical user interfaces (GUIs), such as in mobile devices. User interfaces can include buttons, LEDs, touchscreen sensing and more. Some systems use remote user interfaces as well.

### **3.1.2 Embedded system hardware**

Embedded system hardware can be microprocessor- or microcontroller-based. In either case, an integrated circuit is at the heart of the product that is generally designed to carry out computation for real-time operations. Microprocessors are visually indistinguishable from microcontrollers, but while the microprocessor only implements a central processing unit (CPU) and, thus, requires the addition of other components such as memory chips, microcontrollers are designed as self-contained systems. Microcontrollers include not only a CPU, but also memory and peripherals such as flash memory, RAM or serial communication ports. Because microcontrollers tend to implement full (if relatively low computer power) systems, they are frequently put to use on more complex tasks. For example, microcontrollers are used in the operations of vehicles, robots, medical devices and home appliances, among others. At the higher end of microcontroller capability, the term system on a chip (SoC) is often used.

### **3.1.3 Embedded system software**

A typical industrial microcontroller is unsophisticated compared to the typical enterprise desktop computer and generally depends on a simpler, less-memory-intensive program environment. Often, embedded systems use operating systems or language platforms tailored to embedded use, particularly where real-time operating environments must be served. At higher levels of chip capability, such as those found in SoCs, designers have increasingly decided the systems are generally fast enough and the tasks tolerant of slight variations in reaction time that near-real-time approaches are suitable. In these instances, stripped-down versions of the Linux operating system are commonly deployed, although other operating systems have been pared down to run on embedded systems, including Embedded Java and Windows IoT (formerly Windows Embedded). Generally, storage of

programs and operating systems on embedded devices make use of either flash or rewritable flash.

## **3.2. DELINEATION ABOUT IOT**

### **3.2.1 Introduction**

The Internet of things (IoT) is a system of interrelated computing devices, mechanical and digital machines provided with unique identifiers (UIDs) and the ability to transfer data over a network without requiring human-to-human or human-to-computer interaction. The Internet of things has evolved due to the convergence of multiple technologies, real-time analytics, machine learning, commodity and embedded systems. Traditional fields of embedded systems, automation (including home and building automation), and others all contribute to enabling the Internet of things.

### **3.2.2 Application**

The extensive set of applications for IoT devices is often divided into industrial, consumer and commercial spaces

#### **3.2.2.1 Industrial Application**

Also known as Industrial Internet of Things (IIoT), industrial IoT devices acquire and analyze data from connected equipment.

##### **Energy management**

Significant number of energy companies already have integrated Internet connectivity, which can allow them to communicate with utilities not only to balance power generation but also helps optimize the energy consumption as a whole. These devices allow for remote control by users, or central management via a cloud-based interface, and enable functions like scheduling (e.g., remotely powering on or off systems or controlling the systems based on fault or loading condition). The smart grid is a utility-side IoT application; systems gather and act on energy and power-related information to improve the efficiency of the production and distribution of electricity. Using advanced metering infrastructure (AMI) Internet-connected devices, electric utilities not only collect data from end-users, but also manage distribution automation devices like transformers even the whole substations.

##### **Manufacturing**

The IoT can realize the seamless integration of various manufacturing devices equipped with sensing, identification, processing, communication, actuation, and networking capabilities. The IoT intelligent systems enable rapid manufacturing of products and real-time optimization of manufacturing production and supply chain networks, by networking machinery, sensors and control systems together.

## **Agriculture**

There are numerous IoT applications in farming such as collecting data on temperature, rainfall, humidity, wind speed, pest infestation, and soil content. This data can be used to automate farming techniques, take informed decisions to improve quality and quantity, minimize risk and waste.

## **Infrastructure applications**

Monitoring and controlling operations of sustainable urban and rural infrastructures key application of the IoT. The IoT infrastructure can be used for monitoring any events. The IoT can benefit the construction industry by cost saving, time reduction, better quality workday, paperless workflow and increase in productivity. It can help in taking faster decisions and save money with Real-Time Data Analytics

### **3.2.2.2 Consumer Application**

A growing portion of IoT devices are created for consumers use, including connected vehicles, home automation, wearable technology, connected health, and appliances with remote monitoring capabilities

#### **Smart home**

IoT devices are a part of the larger concept of home automation, which can include lighting, heating and air conditioning, media and security systems. Long-term benefits could include energy savings by automatically ensuring lights and electronics are turned off. A smart home or automated home could be based on a platform or hubs that control smart devices and appliances. This could be a dedicated app or native applications.

#### **Elder care**

One key application of a smart home is to provide assistance for those with disabilities and elderly individuals. These home systems use assistive technology to accommodate an owner's specific disabilities. Voice control can assist users with sight and mobility limitations while alert systems can be connected directly to cochlear implants worn by hearing-impaired users.

### **3.2.2.3 Organisational Application**

#### **Medical and healthcare**

The Internet of medical things (IoMT) is an application of the IoT for medical and health related purposes, data collection and analysis for research, and monitoring. The IoMT has been referenced as "Smart Healthcare", as the technology for creating a digitized healthcare system, connecting available medical resources and healthcare services. IoT devices can be used to enable remote health monitoring and emergency notification systems. These health monitoring devices can range from blood pressure and heart rate monitors to advanced devices capable of

monitoring specialized implants, such as pacemakers, fitness trackers specially wristbands.

### Transportation

The IoT can assist in the integration of communications, control, and information processing across various transportation systems. Dynamic interaction between these components of a transport system enables smart traffic control, smart parking, electronic toll collection systems, logistics and fleet management, vehicle control, safety, and road assistance.

### Environmental monitoring

Environmental monitoring applications of the IoT typically use sensors to assist in environmental protection by monitoring air or water quality, atmospheric or soil conditions, and can even include areas like monitoring the movements of wildlife and their habitats.

## 3.2.3 Technology Roadmap of IoT

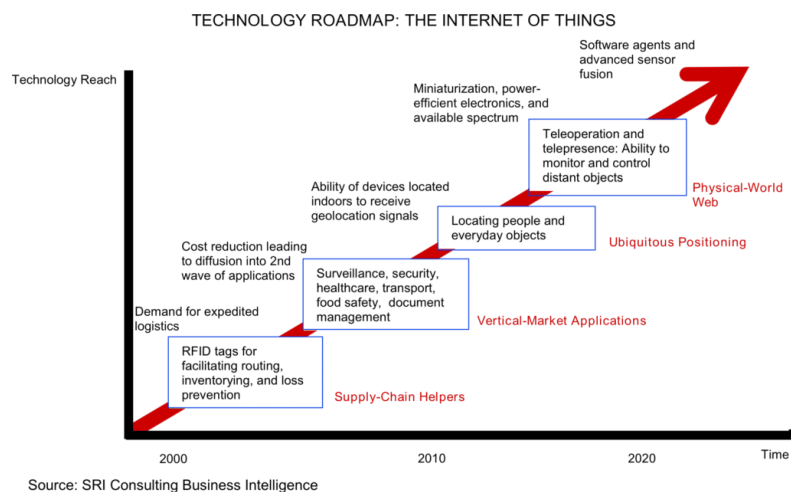

Figure 3.1 Technology Roadmap of IoT

## 3.2.4 Enabling Technologies for IoT

There are many technologies that enable the IoT. Crucial to the field is the network used to communicate between devices of an IoT installation, a role that several wireless or wired technologies may fulfill.

### 3.2.4.1 Addressability

Integration with the Internet implies that devices will use an IP address as a distinct identifier. Due to the limited address space of IPv4, objects in the IoT will have to use the next generation of the Internet protocol i.e., IPv6 to scale to the extremely large address space required.

### 3.2.4.2 Short-range Wireless

**Bluetooth mesh networking** – Specification providing a mesh networking variant to Bluetooth Low

Energy (BLE) with increased number of nodes and standardized application layer (Models).

**Light-Fidelity (Li-Fi)** – Wireless communication technology similar to the Wi-Fi standard, but using visible light communication for increased bandwidth.

**Near-field communication (NFC)** – Communication protocols enabling two electronic devices to communicate within a 4 cm range.

**Radio-frequency identification (RFID)** – Technology using electromagnetic fields to read data stored in tags embedded in other items.

**Wi-Fi** – Technology for local area networking based on the IEEE 802.11 standard, where devices may communicate through a shared access point or directly between individual devices.

**ZigBee** – Communication protocols for personal area networking based on the IEEE 802.15.4 standard, providing low power consumption, low data rate, low cost, and high throughput.

**Z-Wave** – Wireless communications protocol used primarily for home automation and security applications

#### 3.2.4.3 Mid-range Wireless

**LTE-Advanced** – High-speed communication specification for mobile networks. Provides enhancements to the LTE standard with extended coverage, higher throughput, and lower latency.

**5G** - 5G wireless networks can be used to achieve the high communication requirements of the IoT and connect a large number of IoT devices, even when they are on the move.

#### 3.2.4.4 Long-range Wireless

**Low-power wide-area networking (LPWAN)** – Wireless networks designed to allow long-range communication at a low data rate, reducing power and cost for transmission. Available LPWAN technologies and protocols: LoRaWan, Sigfox, NB-IoT, Weightless, RPMA.

**Very small aperture terminal (VSAT)** – Satellite communication technology using small dish antennas for narrowband and broadband data.

#### 3.2.4.5 Wired

**Ethernet** – General purpose networking standard using twisted pair and fiber optic links in conjunction with hubs or switches.

**Power-line communication (PLC)** – Communication technology using electrical wiring to carry power and data. Specifications such as HomePlug or G.hn utilize PLC for networking IoT devices.



### 3.3 AN OVERVIEW ON IED

#### 3.3.1 Introduction

An Intelligent Electronic Device (IED) is a term used in the electric power industry to describe microprocessor-based controllers of power system equipment, such as transformers and capacitor banks. IEDs receive data from sensors and power equipment and can issue control commands, such as tripping circuit breakers if they sense voltage, current, or frequency anomalies. Common types of IEDs include protective relaying devices, On Load Tap Changer controllers, circuit breaker controllers, capacitor bank switches, voltage

regulators etc. Digital protective relays are primarily IEDs, using a microprocessor to perform several protective, control and similar functions. A typical IED can contain around 5-12 protection functions, 5-8 control functions controlling separate devices, an auto-reclose function, self-monitoring function, communication functions etc. Hence, they are aptly named as Intelligent Electronic Devices. Some recent IEDs are designed to support the IEC61850 standard for substation automation, which provides interoperability and advanced communications capabilities.



Figure 3.2 IED based Protective Relay

#### 3.3.2 Holistic View of Automation in Power System

Intelligent electronic devices (IEDs) have been deployed extensively in power automation systems recently, and the shift from RTUs to IEDs is evident due to the integration and interoperability features of the IEDs. IEDs are devices that can be connected to a LAN and communicate with other devices over the LAN and have processing capabilities. Relay IEDs being the most commonly used for automation purposes. Thus, IEDs have become the basic building blocks for automation of power systems. Some of the advanced functions of have been discussed below, -

##### 3.3.2.1 Protection function including Phasor estimation

- The protection function is the primary function of a relay IED, as IEDs are primarily the improvement on the microprocessor-based relays. IEDs have got more accurate measurement principles and less auxiliary equipment are required.
- Auxiliary CTs can be eliminated in a transformer differential relay, as the new relay has a CT mismatch correction function, as the original primary transformer currents are available for further analysis in a modern relay IED.
- Similarly, with appropriate techniques, and numerical comparison algorithms, the CT mismatch, inrush, and CT saturation problems can be solved without external device.

### 3.3.2.2 Programmable Logic & Braker Control

A modern relay IED eliminates the use of external programmable logic controllers (PLCs) as the IED can handle logical inputs and outputs of the protection functions, which can be connected to flip flops and/or gates of the IED directly.

### 3.3.2.3 Metering & Power quality Analysis

- Metering capabilities of the IEDs became acceptable to the power utilities quickly, and major cost saving was achieved by combining the non-revenue metering function into the IEDs.
- It may be noted that the primary CTs and VTs for protection purposes may not be accurate enough for normal current measurement for revenue metering. The normal metering functions include measuring the voltage and current root mean square (RMS) values and the real and reactive power.
- In addition to these basic functions, metering also includes the values for commissioning and testing, and this feature reduces the commission and testing times on the site. The metered values are the positive, negative, and zero sequence components of voltage and current phase shifts and the normal RMS values. The phase mismatch, differential, and restraint values can be computed easily to hasten the commissioning process.

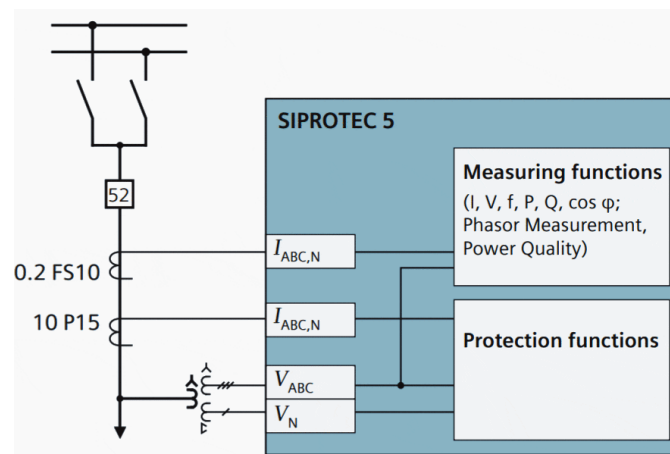

Figure 3.3 Connection to a protection-class and instrument current transformer for a feeder

### 3.3.2.4 Self-monitoring & External Circuit Monitoring

IEDs, in addition to the internal monitoring, have capabilities for interface monitoring and external circuit monitoring.

- Interface monitoring includes checking the inputs to the IEDs and can be verified by simple methods. For example, the input currents to the relay from the three phases should add up to three times the neutral current if any. If there is any deviation, the analog channel of any of the currents could be faulty. The relay can block the false tripping.
- External circuit monitoring will include monitoring of the circuit breaker coil for any interruption in the trip-close path and can also indicate an instrument transformer failure.

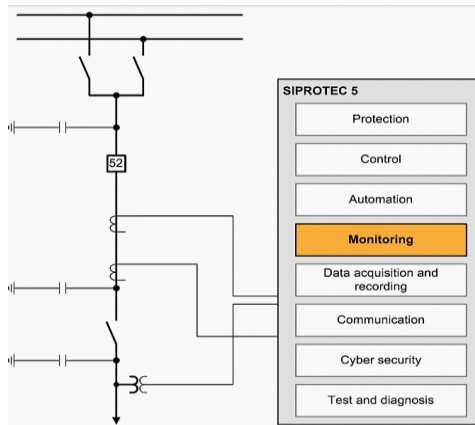

Figure 3.4 Self-monitoring and external circuit monitoring

### 3.3.2.5 Event reporting & Fault diagnosis

Relay IEDs eliminate the digital fault recorders because waveform recording during a fault can be performed by the IEDs, whereas the electromechanical relays did not have such capability. Event reporting can be easily done by relay IEDs eliminating sequence of events (SOE) recorders. The relay IEDs save the captured data in non-volatile memory and disturbance event reports (pick up, trip, and auto-reclose), and general event reports like changes of settings have to be saved and managed separately. Time stamping of all events is done by the IEDs, and GPS synchronization for this purpose and a battery backup for the real-time clock are essential. The events, once time tagged correctly, can be reported in the correct sequence in which they occurred, eliminating further sequencing at the control room. It is hence easy to perform fault diagnosis after a fault, as the values will be saved in the IED and can be retrieved later, even in case of a blackout.

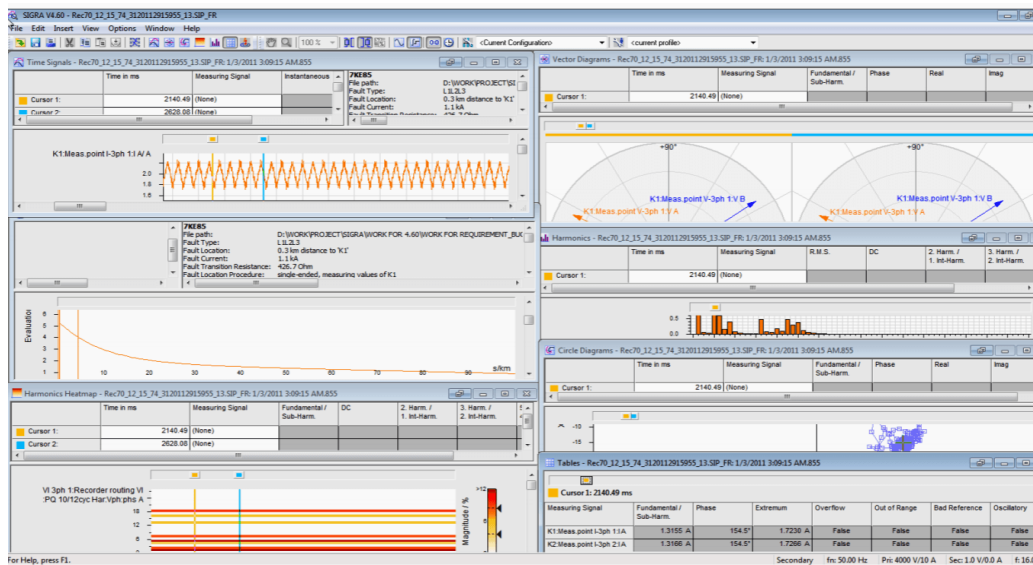
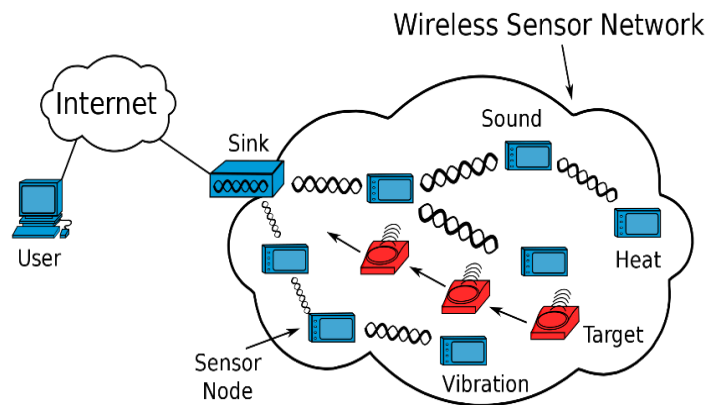

Figure 3.5 The SIGRA application program - It supports the analysis of fault events in your network. It offers a graphic display of the data recorded during the fault event and uses the values measured to calculate further variables, such as impedances, outputs or r.m.s. values, which make it easier for you to analyse the fault record.

## 3.4 WIRELESS SENSOR NETWORK

### 3.4.1 Introduction

Wireless sensor network (WSN) refers to a group of spatially dispersed and dedicated sensors for monitoring and recording the physical conditions of the environment and organizing the collected data at a central location. WSNs measure environmental conditions like temperature, sound, pollution levels, humidity, wind, and so on. These are similar to wireless ad hoc



networks in the sense that they rely on wireless connectivity and spontaneous formation of networks so that sensor data can be transported wirelessly. WSNs are spatially distributed autonomous sensors to monitor physical or environmental conditions, such as current, voltage, temperature, sound, pressure, etc.

### 3.4.2 An overview on WSN

The WSN is built of "nodes" – from a few to several hundreds or even thousands, where each node is connected to one (or sometimes several) sensors. Each such sensor network node has typically several parts: a radio transceiver with an internal antenna or connection to an external antenna, a microcontroller, an electronic circuit for interfacing with the sensors and an energy source, usually an embedded form of energy harvesting. Size and cost constraints on sensor nodes result in corresponding constraints on resources such as energy, memory, computational speed and communications bandwidth. The topology of the WSNs can vary from a simple star network to an advanced multi-hop wireless mesh network. The propagation technique between the hops of the network can be routing or flooding.

# **CHAPTER 4**

## **(THEORITICAL ASPECTS)**

## 4.1 ELECTRICAL SUBSTATION

A **substation** is a part of an electrical generation, transmission, and distribution system. It has crucial function in maintaining the reliability of the electric power supply and to keep the quality of an electric power transmission system. It transforms voltage from high to low, or the reverse, or perform any of several other important functions. Between the generating station and consumer, electric power may flow through several substations at different voltage levels.

### 4.1.1 Classification of Electrical Substation

#### 4.1.1.1 Broader Classification



Figure 4.1 A Typical Substation

The substations may be classified in numerous ways, such as by nature of duties, service rendered operating voltage, importance, and design.

#### Classification of Substations by Nature of Duties

- Step-up or Primary Substations
- Primary Grid Substations
- Step-down or Distribution Substations

#### Classification of Substations by Service Rendered

- Transformer substations
- Switching Substations
- Converting Substations

#### Classification of Substations by Operating Voltage

- High Voltage Substations (HV Substations)
- Extra High Voltage Substations
- Ultra-High Voltage

## Classification of Substations by Design

- Indoor Type Substations
- Outdoor Substations
- Pole Mounted Substations
- Foundation Mounted Substations

### 4.1.1.2 Generic Classification

#### Step-up Substation

A step-up substation receives electric power from a nearby generating facility and uses a large power transformer to increase the voltage for transmission to distant locations.



Figure 4.2 Step-up substation

#### Step-down Substation

Step-down substations are located at switching points in an electrical grid. They connect different parts of a grid and are a source for subtransmission lines or distribution lines. The step-down substation can change the transmission voltage to a subtransmission voltage. The subtransmission voltage lines can then serve as a source to distribution substations.



Figure 4.3 Step-down substation

#### Underground Substation

Underground distribution substations are also located near to the end-users. Distribution substation transformers change the subtransmission voltage to lower levels for use by end-users.

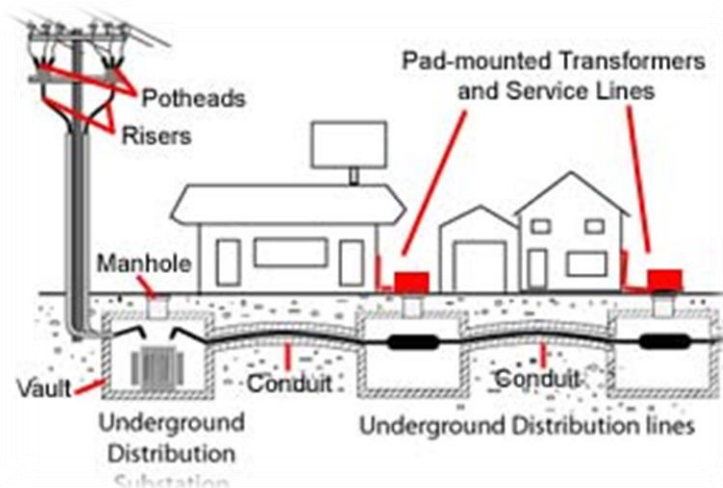
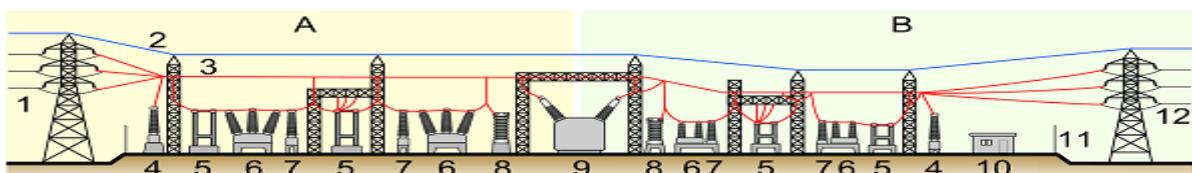

Figure 4.4 Underground Substation

### 4.1.2 Components of Electrical Substation

The electricity substation designs are purely dependent on the need, for instance, a single bus or complex bus system etc. Moreover, the design is also dependent on the application as well, for instance, indoor substations, generation substations, transmission substations, pole substations, outdoor substation, converter substation, and switching substation etc. There is a need of collector substation as well in cases of large power generating systems e.g. multiple thermal and hydropower plants connected together for transfer of power to a single transmission unit. The following are major electrical components of substations and their working. Each component functions are explained in detail, -



A: Primary power lines' side, B: Secondary power lines' side

1-Primary power lines, 2- Ground wire, 3- Overhead lines, 4- Transformer for measurement of electric voltage, 5- Disconnect switch, 6- Circuit breaker, 7- Current transformer, 8- Lightning arrester, 9- Main transformer, 10- Control building, 11- Security fence, 12- Secondary power lines

#### 4.1.2.1 Instrument Transformers

The instrument transformer is a static device utilized for reduction of higher currents and voltages for safe and practical usage which are measurable with traditional instruments such as digital multi-meter etc. These transformers are also used for actuation of AC protective relay through supporting voltage and current. Instrument transformers are



Figure 4.5 Instrument Transformer



shown in the figure below and its two types are also discussed underneath.

### **Current Transformer**

A current transformer is utilized for the transformation of higher value currents into lower values. It is utilized in an analogous manner to that of AC instruments, control apparatus, and meters.



Figure 4.6 Current Transformer

### **Potential Transformer**

The potential transformers are similar in characteristics as current transformers but are utilized for converting high voltages to lower voltages for protection of relay system and for lower rating metering of voltage measurements.



Figure 4.7 Potential Transformer

### **4.1.2.2 Busbars**

The busbar is among the most important elements of the substation and is a conductor which carries current to a point having numerous connections with it. The busbar is a kind of electrical junction which has outgoing and incoming current paths. These are of different types such as ring bus, double bus, and single bus etc. A simple bus bar is shown in the figure.



Figure 4.8 Busbars

### **4.1.2.3 Lightning Arrester**

The lightning arresters are having a function of protecting equipment of substation from high voltages and are also limiting the amplitude and duration of the current's flow. These are connected amid earth and line i.e. connected in line with equipment in the substation. These are meant for diversion of current to earth if any current surge appears hence by protecting insulation as well as conductor from damages.



Figure 4.9 Lightning Arrester

### **4.1.2.4 Circuit Breaker**

circuit breakers are such type of switches utilized for closing or opening circuits at the time when a fault occurs within the system. At the time when any fault occurs in the system, a relay is sending the tripped command to the circuit breaker which moves the contacts apart, hence avoiding any damage to the circuitry.



Figure 4.10 Circuit Breaker

#### 4.1.2.5 Relay

Relays are a dedicated component of electrical substation equipment for the protection of system against abnormal situations e.g. faults. Relays are basically sensing devices which are devoted for sensing faults and are determining its location as well as sending interruption message of tripped command to the specific point of the circuit.



Figure 4.11 Relay

#### 4.1.2.6 Capacitor Bank

The capacitor bank is defined as a set of numerous identical capacitors which are connected either in parallel or series inside an enclosure and are utilized for the correction of power factor as well as protection of circuitry of the substation.



Figure 4.12 Capacitor Bank

#### 4.1.2.7 Battery Bank

Some of the important substation parts such as emergency lighting, relay system, and automated control circuitry are operated through batteries.



Figure 4.13 Battery Bank

#### 4.1.2.8 Wave Tapper

The wave trapper is one of the substation components which is placed on the incoming lines for trapping of high-frequency waves. The high-frequency waves which are coming from nearby substations or other localities are disturbing the current and voltage

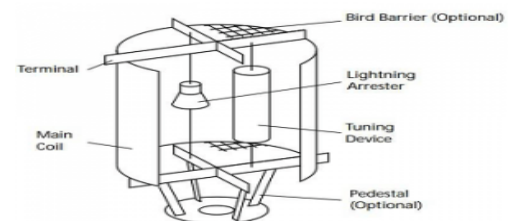

Figure 4.14 Wave Tapper

## 4.2 MAINTENANCE OF THE SUBSTATIONS

Maintenance is a key activity at power system in order to assure the proper operation of the system. It implies a huge amount of human and economic resources for utilities. On one hand, liberalization and privatization of electric markets have resulted in a more competitive environment. Moreover, current infrastructure is stressing and ageing. Keep costs down, increase incomes and improve reliability means that it is needed to invest in new maintenance strategies. On the other hand, surveys indicate that current maintenance procedures consist principally on corrective and preventive (time-based). The former is used for assets that are abundant, non-essential and easy to replace, and also for those that have already had a failure, if it is repairable. The latter, the most used nowadays, consists on assessing the condition of assets according to a schedule defined by manufacturer's specifications and utilities' experience. Nevertheless,

time-based maintenance usually means over-maintenance for new assets and under maintenance for aged assets. In order to improve the cost-effectiveness of the maintenance, a shift from preventive maintenance based on time (TBM) towards a maintenance based on condition (CBM) is taking place. CBM strategies permit optimizing maintenance and operation costs, while at the same time the quality and continuity of the electrical supply is improved due to a better utilization of assets. Condition monitoring system is the core element for developing predictive maintenance and for Reliability Centered Maintenance (RCM) later on. Predictive maintenance improves utilization and maintenance of power system assets since it allows having measurements and operational parameters of them. These permits either to anticipate to breakdowns or incidents at the distribution network. RCM is a more cost-effective maintenance strategy that includes criticality and significance of assets in the whole system, besides asset condition. A project regarding monitoring is presented following. It is focus on two main assets at substations: power transformers because their significant both technical and economical, impact and circuit-breakers because their important rate of incidents.

### **4.3 MONITORING SYSTEM**

Monitoring is a key-tool for utilities in order to shift from corrective or time-based maintenance strategies to predictive maintenance. It is the first step towards the implementation of CBM strategy. Monitoring consists basically on acquiring significant parameters from the assets of interest. The collected data allow carrying out analyses and diagnose the condition of the assets which is of great use as a support to the decision-making maintenance schedule and then, reducing failures and breakdowns. The huge amount of features to consider makes substation monitoring complex. It can be both on-line (continuous) and off-line (discontinuous), or a combination of both, depending on the asset and the diagnosis to perform. Proper sensors and data acquisition and software to process them are also needed. Moreover, substations are built with assets from different manufacturers the usual variety of communication protocols, too. A monitoring system can be structured in three levels, -

Level 1: Data acquisition from each asset through appropriated sensors.

Level 2: Data storage and processing at substation level.

Level 3: Integration of the data from different

#### **4.3.1 What is Substation Monitoring System?**

Substation monitoring system refers to an ecosystem consisting of hardware and software components that is used to monitor substation equipment, such as transformers, switching devices, and circuit breakers, among others. Substation monitoring system is used across transmission and distribution substations to collect real time data of individual equipment as the entire operational status of the substation. This data monitoring carried out by the substation monitoring system helps to identify the

faults, trips, or breakages in the substation equipment, enabling quick response to tackle any such event. Substation monitoring system helps with the protection and reliable operation of substation equipment.

### **4.3.2 IEC 61850**

The specifications of a substation monitoring system are highly variable, depending on the type of substation, voltage levels, load capacity, grid integration and many other technical parameters. Substation monitoring system may be installed in a given substation on a standalone basis, or often integrated as part of a wider substation automation system. In view of the criticality of their application, a wide range of regulations and standards govern the specification, design, engineering and application of substation monitoring system, both for hardware and software components. Providers of substation monitoring system widely use standards and protocols determined by the International Electrotechnical Commission (IEC) on an international scale, along with the other regional standards that may apply in specific territories. **IEC 61850** is an international standard defining communication protocols for intelligent electronic devices at electrical substations. It is a part of the International Electrotechnical Commission's (IEC) Technical Committee 57 reference architecture for electric power systems.

#### **4.3.2.1 Features of IEC 61850**

##### **Data Modeling**

Primary process objects as well as protection and control functionality in the substation is modelled into different standard logical nodes which can be grouped under different logical devices. There are logical nodes for data/functions related to the logical device (LLN0) and physical device (LPHD).

##### **Reporting Schemes**

There are various reporting schemes (BRCB & URCB) for reporting data from server through a server-client relationship which can be triggered based on pre-defined trigger conditions.

##### **Fast Transfer of events**

Generic Substation Events (GSE) are defined for fast transfer of event data for a peer-to-peer communication mode. This is again subdivided into GOOSE & GSSE.

##### **Setting Groups**

The setting group control Blocks (SGCB) are defined to handle the setting groups so that user can switch to any active group according to the requirement.

##### **Sampled Data Transfer**

Schemes are also defined to handle transfer of sampled values using Sampled Value Control blocks (SVCB)

**Commands**

Various command types are also supported by IEC 61850 which include direct & select before operate (SBO) commands with normal and enhanced securities.

**Data Storage**

Substation Configuration Language (SCL) is defined for complete storage of configured data of the substation in a specific format.

# CHAPTER 5

## (METHODOLOGY)

## 5.1 WHAT WE WANT TO DO?

As complexity of distribution network has grown, automation of substation has become a need of every utility company to increase its efficiency and to improve quality of power being delivered. Today electricity still suffers from power outages and blackouts due to the lack of automated analysis and poor visibility of the utility over the grid. To Improve the quality of power with suffer solution it is necessary to be familiar with what sort of constraint has occurred. Additionally, if there is any inadequacy in the protection, monitoring and control of a power system. The system might become unstable. Therefore, it necessary a monitoring system that is able to automatically detect, monitor, and classify the existing constraints on electrical lines. The purpose of this project is to acquire the remote electrical parameters like voltage, current and frequency and send these real time values over network using IoT module along with temperature at power station.

This project is also designed to protect the electrical circuitry by operating a relay. This relay gets activated whenever the electrical parameters exceeds the predefined values. This system can automatically update the real time electrical parameters periodically (based on time settings). This system can be designed to send alerts whenever the relay trips or whenever the voltage or current exceeds the predefined limits. This project makes use of a microcontroller, as this is a prototype of the proposed project, for demonstration purpose we have used Arduino Uno here. The controller can efficiently communicate with the different sensors being used.

### 5.1.1 Block Diagram of the Prototype

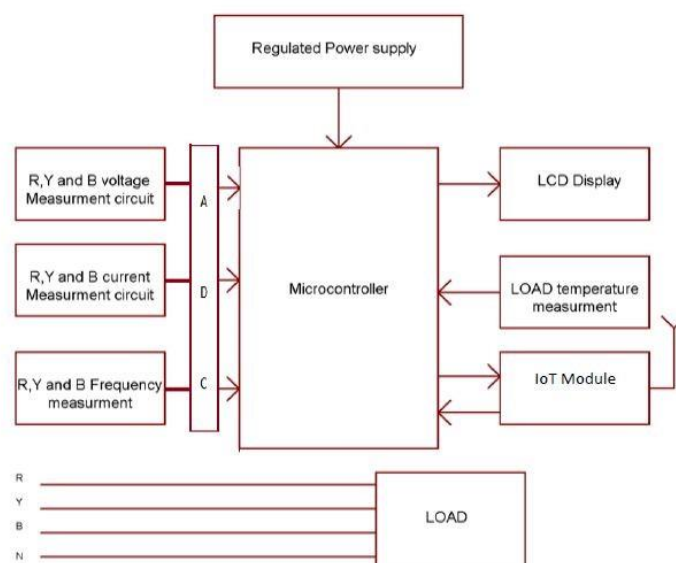

## 5.2 LOGIC & OPERATION

### 5.2.1 Flow Chart of the Prototype

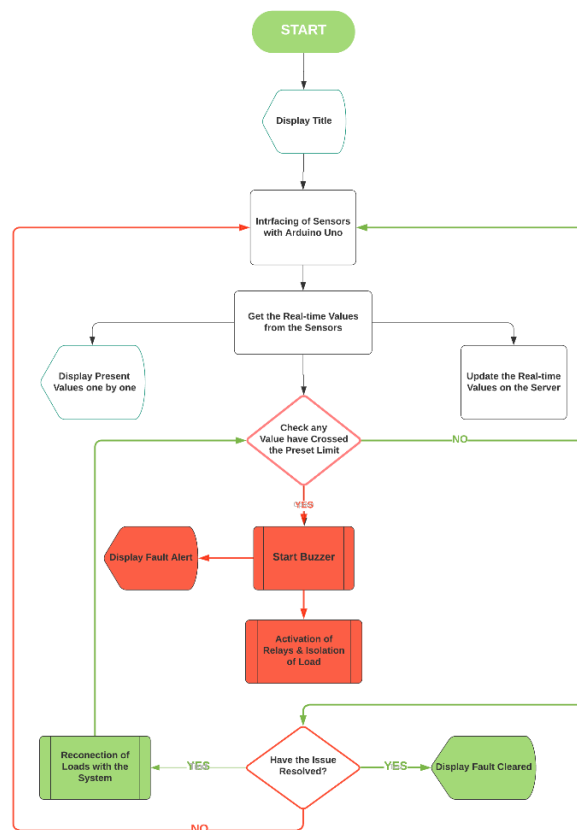

### 5.2.2 Principle of Operation

Here in the proposed prototype we have used Arduino Uno as our primary microcontroller. It will work as the heart of the system; all other measurement circuitries will be interfaced through this. All the detailed specifications will be discussed in the next chapter, nevertheless let me take you through the basic components for better understanding the rest of the operation. Besides the microcontroller we have used current sensor, voltage sensor, temperature sensor, frequency measurement unit, buzzer and relay; and to demonstrate the load we have used a fan and a bulb. Alongside we also have used a supply unit, consisting of a transformer, which converts 230 Volt AC to 12 Volt AC then it is passed through bridge rectifier unit which converts this 12 Volt AC to 12 Volt DC which is pulsating in nature which is then fed to the capacitor which work as a filter, makes the pulsating DC to smooth DC. As a lot of our components like Arduino Uno and some of the sensors as well require 5 Volt regulated DC, that is why this 12 Volt DC is fed to 7805 Voltage regulator which makes it to 5 Volt regulated DC. In case of buzzer and relay need high amount of current for operation, we have to make some arrangements for that. For that amplification arrangement in case of relay we have used a relay driver and for buzzer we have used two BC 547 transistor in Darlington pair configuration. For operation of the green and



red LEDs which work as a indicator they also need large amount of current for their amplified current requirement we have used two BC 547 transistors one for each.

When we give supply to our prototype the display shows a welcome message and simultaneously all the sensor start sensing the current, voltage, frequency and temperature and update all the real time values to the server as well as shows on the display. It compares all the real time values with the pre-defined values, if any of the values exceeds pre-defined values it sends a fault alert to the relay and buzzer as well as update it on the display. If the fault exists for the pre-set time then relay isolates the loads from the rest of the system. In the meantime, comparison goes on as before, if the fault gets cleared relays reconnect the loads with the rest of the system.

### 5.3 MAIN FEATURES OF THE PROJECT

The features of the developed prototype are: -

**Display capabilities** - With the help of 16\*2 LCD display it can show the real time data like current, voltage, frequency & temperature value. It can show the alert message as well.

**Different electrical parameter sensing capabilities** - In this prototype we have included sensors like current, voltage & and temperature sensor. As well as we can measure the supply frequency with frequency measurement techniques.

**Independent load can be controlled** - In this prototype we can individually control our loads i.e., fan and bulb.

**Real time monitoring** - With the help of sensors and other measurement techniques we can monitor the real time data.

**Periodical collection of data** - We can collect data the through the different measurement techniques and display those, which is repeated periodically after a set time.

**Error free data** - As all the data are collected through different measurement techniques without any manual intervention, that is why data collected are mostly error free.

**Personalised alert over fault** - In case of any fault buzzer starts which causes an alarm over fault besides that display also shows the Personalised reason of the fault.

**Cost effective** - We have built this prototype with only necessary components, we have not included any unnecessary components, what made our project cost effective.

## 5.4 COMPONENTS REQUIRED

Sl. No.	Components	Quantity
1	Arduino Uno	1
2	ACS712 Current Sensor	1
3	ZMPT101B Voltage Sensor	1
4	LM 35 Temperature Sensor	1
5	16*2 LCD Display	1
6	230 V/12 V Step-down Transformer	1
7	1N4007 Diode	4
8	Electrolytic Capacitor (470 $\mu$ F)	1
9	Film Capacitor (0.1 $\mu$ F)	2
10	IC7805 Voltage Regulator	1
11	SRD-05VDC-SL-C Two Channel Relay Module	1
12	PC817 Optocoupler	1
13	Piezo Buzzer	1
14	BC 547 Transistor	5
15	Resistor (330 $\Omega$ , 110 k $\Omega$ , 33 k $\Omega$ , 10 k $\Omega$ )	5 of each
16	Potentiometer (10k)	1
17	Bulb (Philips 5 Watt LED)	1
18	Fan (Brushless DC 3.5" Fan)	1
19	Push Button	5
20	Toggle Switch	1
21	3 mm LED	4
22	10 mm LED	2
23	Male Pin Header	1
24	Female Pin Header	1
25	Bread Board	1
26	Veroboard (10cm/10cm)	4
27	Card Board (2'2')	1
28	AC Power Cable	3 meters
29	Jumper Wire	15
30	Wire Nipper	1
31	Wire Striper	1
32	Soldering Iron	1
33	Soldering Material Rill	1

Table 5.1 Components Required

## 5.5 COST ESTIMATION

Sl. No.	Components	Quantity	Price (INR)
1	Arduino Uno	1	499
2	ACS712 Current Sensor	1	230
3	ZMPT101B Voltage Sensor	1	200
4	LM 35 Temperature Sensor	1	50
5	16*2 LCD Display	1	125
6	230 V/12 V Step-down Transformer	1	145
7	1N4007 Diode	4	1*4
8	Electrolytic Capacitor (470 $\mu$ F)	1	50
9	Film Capacitor (0.1 $\mu$ F)	2	26*2
10	IC7805 Voltage Regulator	1	44
11	SRD-05VDC-SL-C Two Channel Relay Module	1	87
12	PC817 Optocoupler	1	2
13	Piezo Buzzer	1	15
14	BC 547 Transistor	5	2*5
15	Resistor (330 $\Omega$ , 110 k $\Omega$ , 33 k $\Omega$ , 10 k $\Omega$ )	5 of each	(1*5) +(1*5) +(1*5) +(1*5)
16	Potentiometer (10k)	1	10
17	Bulb (Philips 5 Watt LED)	1	80
18	Fan (Brushless DC 3.5" Fan)	1	100
19	Push Button	5	7*5
20	Toggle Switch	1	15
21	3 mm LED	4	2*4
22	10 mm LED	2	3*2
23	Male Pin Header	1	10
24	Female Pin Header	1	10
25	Bread Board	1	40
26	Veroboard (10cm/10cm)	2	50*2
27	Card Board (2'/2')	1	150
28	AC Power Cable	3 meters	23
29	Jumper Wire	15	55
30	Wire Nipper	1	50
31	Wire Striper	1	62
32	Soldering Iron	1	250
33	Soldering Material Rill	1	20
	<b>TOTAL</b>		<b>Rs. 2557 /-</b>

Table 5.2 Cost Estimation

# CHAPTER 6

## (IMPLEMENTATION)

## 6.1 PROJECT LAYOUT

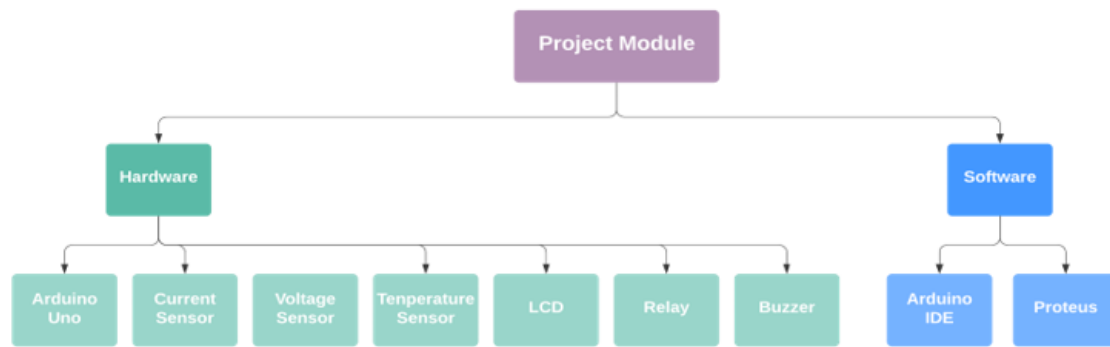

Figure 6.1 Project Layout

## 6.2 COMPONENTS

Our components part is mainly divided into eight part viz.,

- Primary Microcontroller Unit
- Power Supply Processing Unit
- Current Measurement Unit
- Voltage Measurement Unit
- Frequency Measurement Unit
- Temperature Measurement Unit
- Protection Unit
- Display Unit

### 6.2.1 Primary Controller Unit

Here we have used Arduino Uno as our primary microcontroller.

#### 6.2.1.1 Arduino Uno

The Arduino Uno is an open source microcontroller board based on the microchip ATmega328P microcontroller and developed by Arduino.cc. The board is equipped with sets of digital and analog input/output (I/O) pins that may be interfaced to various expansion boards (shields) and other circuits. The board has 14 digital I/O pins (six capable of PWM output), 6 analog I/O pins, a 16 MHz ceramic resonator (CSTCE16M0V53-R0), a USB connection, a power jack, an ICSP header, a reset button, and is programmable with the Arduino IDE (Integrated Development Environment), via a type



Figure 6.2 Arduino Uno Board

B USB cable. It can be powered by the USB cable or by an external 9-volt battery, though it accepts voltages between 7 and 20 volts.

### Technical Specifications

Microcontroller	ATmega328P
Operating Voltage	5V
Input Voltage (recommended)	7-12V
Input Voltage (limit)	6-20V
Digital I/O Pins	14 (of which 6 provide PWM output)
PWM Digital I/O Pins	6
Analog Input Pins	6
DC Current per I/O Pin	20 mA
DC Current for 3.3V Pin	50 mA
Flash Memory	32 KB (ATmega328P) of which 0.5 KB used by bootloader
SRAM	2 KB (ATmega328P)
EEPROM	1 KB (ATmega328P)
Clock Speed	16 MHz
LED_BUILTIN	13
Length	68.6 mm
Width	53.4 mm
Weight	25 g

Table 6.1 Technical Specification of Arduino Uno

### Pin Overview

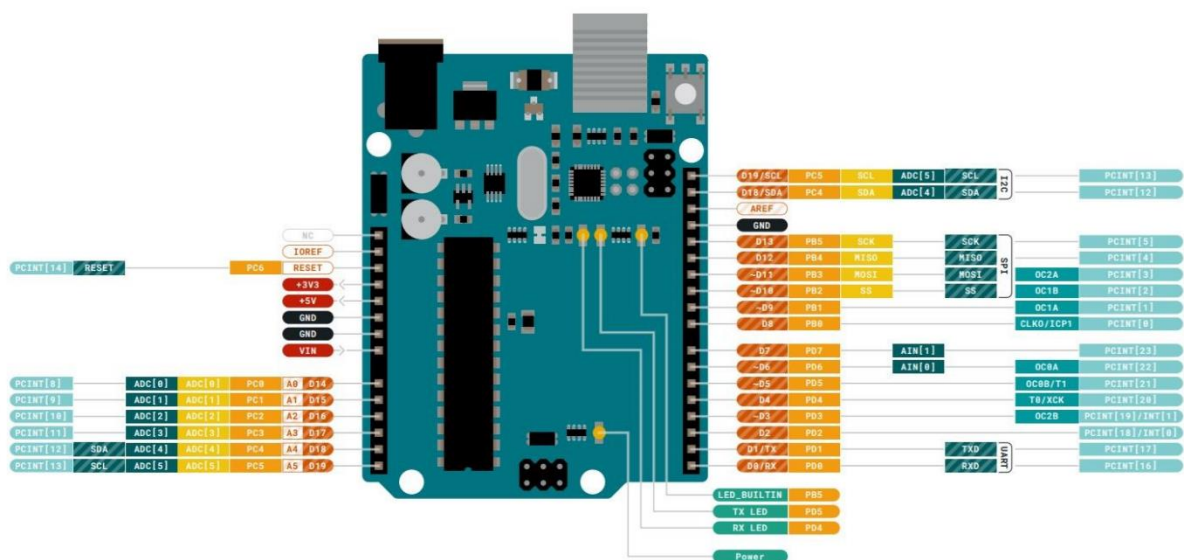

Figure 6.3 Full Schematics of Arduino Uno

- **General pin functions**

**LED:** There is a built-in LED driven by digital pin 13. When the pin is high value, the LED is on, when the pin is low, it is off.

**VIN:** The input voltage to the Arduino board when it is using an external power source (as opposed to 5 volts from the USB connection or other regulated power source). You can supply voltage through this pin, or, if supplying voltage via the power jack, access it through this pin.

**5V:** This pin outputs a regulated 5V from the regulator on the board. The board can be supplied with power either from the DC power jack (7 - 20V), the USB connector (5V), or the VIN pin of the board (7-20V). Supplying voltage via the 5V or 3.3V pins bypasses the regulator, and can damage the board.

**3V3:** A 3.3 volt supply generated by the on-board regulator. Maximum current draw is 50 mA.

**GND:** Ground pins.

**IOREF:** This pin on the Arduino board provides the voltage reference with which the microcontroller operates. A properly configured shield can read the IOREF pin voltage and select the appropriate power source, or enable voltage translators on the outputs to work with the 5V or 3.3V.

**Reset:** Typically used to add a reset button to shields that block the one on the board.

- **Special pin functions**

Each of the 14 digital pins and 6 analog pins on the Arduino Uno can be used as an input or output, under software control (using `pinMode()`, `digitalWrite()`, and `digitalRead()` functions). They operate at 5 volts. Each pin can provide or receive 20 mA as the recommended operating condition and has an internal pull-up resistor (disconnected by default) of 20-50K ohm. A maximum of 40mA must not be exceeded on any I/O pin to avoid permanent damage to the microcontroller. The Uno has 6 analog inputs, labeled A0 through A5; each provides 10 bits of resolution (i.e. 1024 different values). By default, they measure from ground to 5 volts, though it is possible to change the upper end of the range using the AREF pin and the `analogReference()` function. In addition, some pins have specialized functions:

**Serial / UART:** pins 0 (RX) and 1 (TX). Used to receive (RX) and transmit (TX) TTL serial data. These pins are connected to the corresponding pins of the ATmega8U2 USB-to-TTL serial chip.

**External interrupts:** pins 2 and 3. These pins can be configured to trigger an interrupt on a low value, a rising or falling edge, or a change in value.

**PWM (pulse-width modulation):** pins 3, 5, 6, 9, 10, and 11. Can provide 8-bit PWM output with the `analogWrite()` function.

**SPI** (Serial Peripheral Interface): pins 10 (SS), 11 (MOSI), 12 (MISO), and 13 (SCK). These pins support SPI communication using the SPI library.

**TWI** (two-wire interface) / **I<sup>2</sup>C**: pin SDA (A4) and pin SCL (A5). Support TWI communication using the Wire library.

**AREF** (analog reference): Reference voltage for the analog inputs.

## 6.2.2 Power Supply Processing Unit

Power Supply Processing Unit (PSPU) is consisting of one 230 Volt to 12 Volt Step-down Transformer, one Bridge Rectifier unit made up of four 1N4007 rectifier diode, one 470  $\mu$ F Capacitor, one IC7805 Voltage-regulator and two 0.1  $\mu$ F Film-capacitors.

At first 230 Volt, 50 Hz single-phase AC supply is converted to 12 Volt, 50Hz AC; then which is fed to the bridge-rectifier unit which converts it to 12 Volt DC which is pulsating in nature; to make it smooth DC we then pass it through the filter circuit which is a capacitor of 470  $\mu$ F, which makes this pulsating DC to approximately smooth DC. As a lot of components along with our primary  $\mu$ C need 5V DC; that is why we then fed this 12 Volt smooth DC to the IC7805 which is a voltage regulator, which converts the 12 Volt DC to 5 Volt DC.

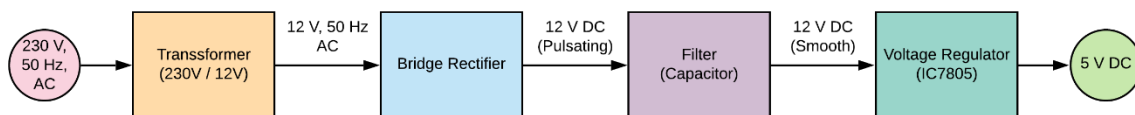

Figure 6.4 Block Diagram of PSPU

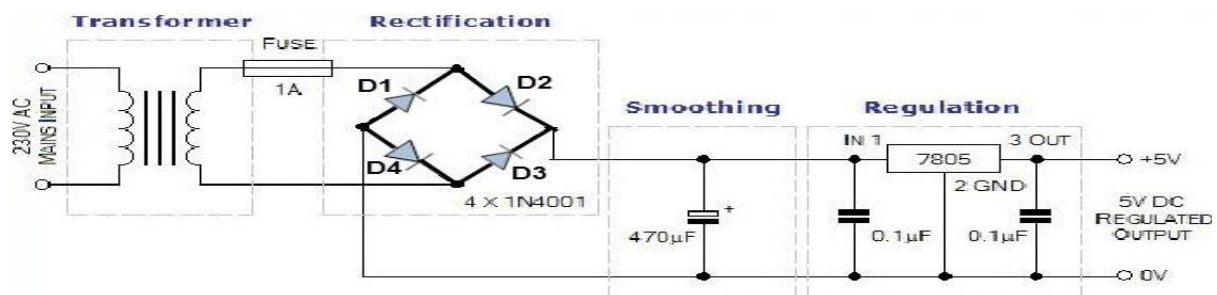

Figure 6.5 Circuit Diagram of PSPU

### 6.2.2.1 Transformer

A Transformer is defined as a passive electrical device that transfers electrical energy from one circuit to another through the process of electromagnetic induction. It is mostly used to increase ('step-up') or decrease ('step-down') voltage levels between circuits. It works on the principle of Faraday's Law of Electromagnetic Induction which states that "The magnitude of voltage is directly proportional to the rate of change of flux." In general, the primary coil of the transformer receives the voltage which is alternating in nature. The alternating current following the coil produces a continuously changing and alternating flux which is produced around the primary winding. Then we have the other coil or the secondary coil which is near to the primary coil which



get linked to the primary because some alternating flux gets linked. As the flux is changing continuously it induces a EMF induced in the secondary coil according to the Faraday's law of electromagnetic induction. If the secondary side circuit is closed a current will flow and this is the most basic working of a transformer.

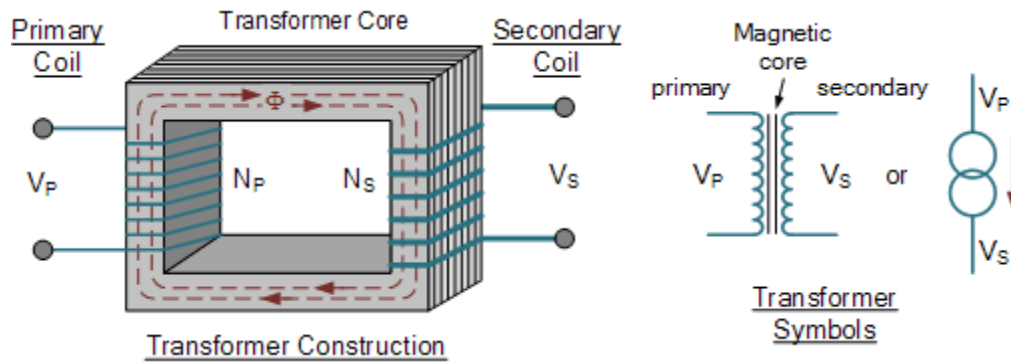

Figure 6.6 Transformer Basics

### 6.2.2.2 Bridge Rectifier

This consists of a bridge circuit which includes four diodes. These can be individual diodes, or it is also easy to obtain bridge rectifiers as a single electronic component. The bridge rectifier provides full wave rectification and has the advantage over the full wave rectifier using two diodes that no center-tap is required in the transformer. This means that a single winding is used for both halves of the cycle. In view of its performance and capabilities, the full wave bridge rectifier is used in many linear power supplies, switch mode power supplies and other electronic circuits where rectification is needed.

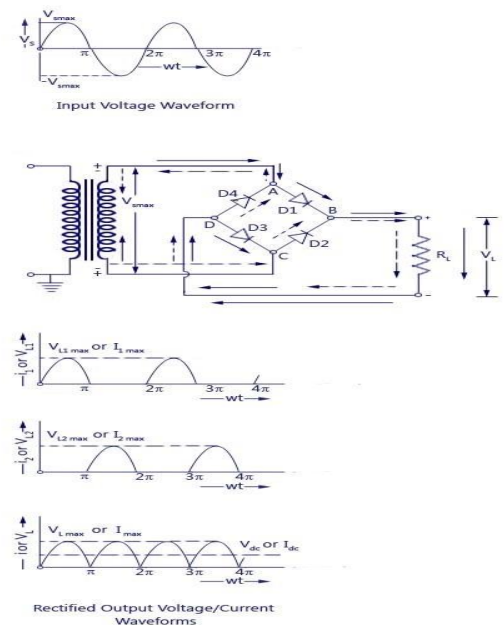

Figure 6.7 Bridge Rectifier

### 6.2.2.3 Filter

The outputs of all rectifier circuits contain some ripple factor. The ripple in the signal denotes the presence of some AC component. This ac component has to be completely removed in order to get pure dc output. A circuit that **smoothens** the rectified output into a pure dc signal is basically Filter Circuit. The following figure shows the functionality of a filter circuit.

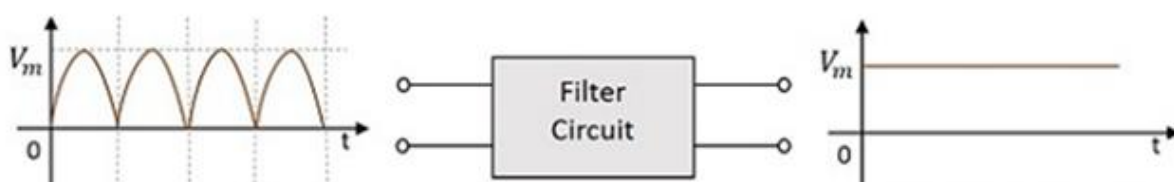

Figure 6.8 Functionality of Filter Circuit

Some of the basic kind of filters are as follows, -

- Series Inductor Filter
- Shunt Capacitor Filter
- L-C Filter
- Pi ( $\pi$ ) Filter

Here we have only used Shunt Capacitor Filter that is why we only discuss about that.

### Shunt Capacitor Filter

As a capacitor allows ac through it and blocks dc, a filter called **Shunt Capacitor Filter** can be constructed using a capacitor, connected in shunt, as shown in the following figure.

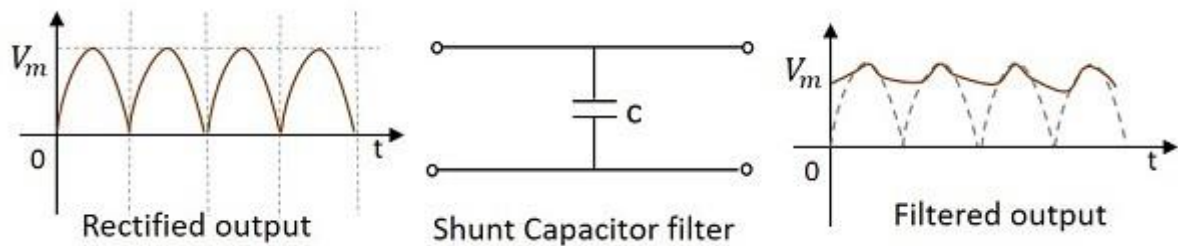
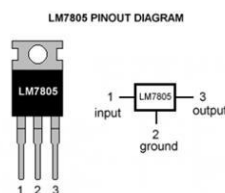

Figure 6.9 Functionality of Shunt Capacitor Filter

#### 6.2.2.4 Voltage Regulator

A voltage regulator IC maintains the output voltage at a constant value the **voltage regulator IC 7805** is actually a member of the 78xx series of voltage regulator ICs. It is a fixed linear voltage regulator. The xx present in 78xx represents the value of the fixed output voltage that the particular IC provides. For 7805 IC, it is +5V DC regulated power supply. The input voltage to this voltage regulator can be up to 35V, and this IC can give a constant 5V for any value of input less than or equal to 35V which is the threshold limit

#### Pin-out of LM7805



Pin No.	Pin	Function	Description
1	INPUT	Input voltage (7V-35V)	In this pin of the IC positive unregulated voltage is given in regulation.
2	GROUND	Ground (0V)	In this pin where the ground is given. This pin is neutral for equally the input and output.
3	OUTPUT	Regulated output; 5V (4.8V-5.2V)	The output of the regulated 5V volt is taken out at this pin of the IC regulator.

## Schematics of LM7805

The heart of the 7805 IC is a transistor (Q16) that controls the current between the input and output and thus controlling the output voltage. The bandgap reference (yellow) keeps the voltage stable. It takes the scaled output voltage as input (Q1 and Q6) and provides an error signal (to Q7) for indication if the voltage is too high or low. The key task of the bandgap is to provide a stable and accurate reference, even as the chip's temperature changes. The error

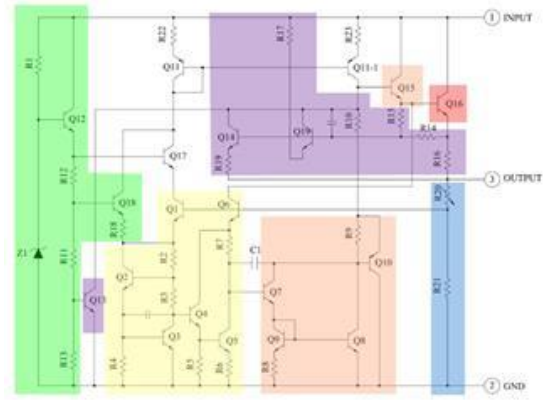

Figure 6.10 Schematics of LM7805

signal from the bandgap reference is amplified by the error amplifier (orange). This amplified signal controls the output transistor through Q15. This closes the negative feedback loop controlling the output voltage. The start-up circuit (green) provides initial current to the bandgap circuit, so it doesn't get stuck in an "off" state. The circuit in purple provides protection against overheating (Q13), excessive input voltage (Q19) and excessive output current (Q14). These circuits reduce the output current or shutdown the regulator, protecting it from damage in case of a fault. The voltage divider (blue) scales down the voltage on the output pin for use by the bandgap reference.

## Features

- 5V Positive Voltage Regulator
- Minimum Input Voltage is 7V
- Maximum Input Voltage is 25V
- Operating current ( $I_Q$ ) is 5mA
- Internal Thermal Overload and Short circuit current limiting protection is available.
- Junction Temperature maximum 125 degree Celsius

## Connection Diagram

The above circuit shows all the components required for a 7805 IC to work properly. The 0.22 $\mu$ F Capacitor near the input is required only if the distance between the regulator IC and the power supply filter is high. Also, the 0.1 $\mu$ F Capacitor near the output is optional and if used, it helps in the transient response.

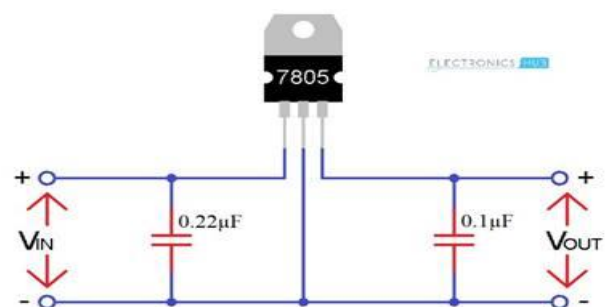

Figure 6.11 Connection Diagram of LM7805

## Applications

7805 IC is used in a wide range of circuits. The major ones being:

- Fixed-Output Regulator
- Positive Regulator in Negative Configuration
- Adjustable Output Regulator
- Current Regulator
- Adjustable DC Voltage Regulator
- Regulated Dual-Supply
- Output Polarity-Reversal-Protection Circuit
- Reverse bias projection Circuit

7805 IC also finds usage in building circuits for inductance meter, phone charger, portable CD player, infrared remote-control extension and UPS power supply circuits.

### 6.2.3 Current Measurement Unit

Here we have used ACS712 Current sensor for current measurement in our prototype.

#### 6.2.3.1 ACS712 Current Sensor

The ACS712 provides economical and precise solutions for AC or DC current sensing in industrial, commercial, and communications systems. The device package allows for easy implementation by the customer. Typical applications include motor control, load detection and management, switched-mode power supplies, and over current fault protection.

The ACS712 Module uses the famous ACS712 IC to measure current using the Hall Effect principle. The ACS712 module has two phoenix terminal connectors with mounting screws. These are the terminals through which the wire has to be passed. On the other side we have three pins. The Vcc is connected to +5V to power the module and

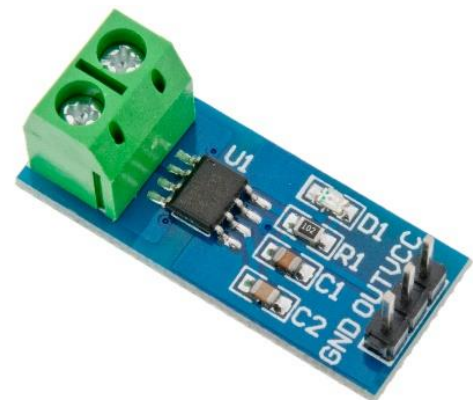

Figure 6.12 ACS712 Current Sensor

the ground is connected to the ground of the  $\mu\text{C}$ . Then the analog voltage given out by the ACS712 module is read using any analog pin on the  $\mu\text{C}$ .

### Pin Diagram of ACS712

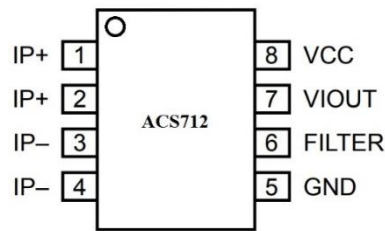

Figure 6.13 Pin Diagram of ACS712

Number	Name	Description
1 & 2	IP+	Terminals for current being sensed; fused internally
3 & 4	IP-	Terminals for current being sensed; fused internally
5	GND	Signal ground terminal
6	FILTER	Terminal for external ground capacitor that sets bandwidth
7	VIOU	Analog output terminal
8	VCC	Device power supply terminal

### Typical Application Connection

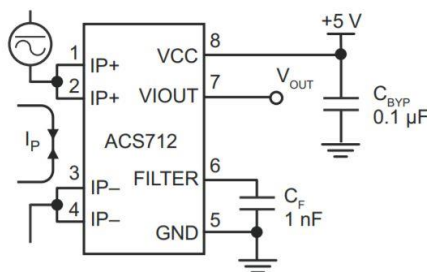

Figure 6.14 Typical Application Pin-out of ACS712

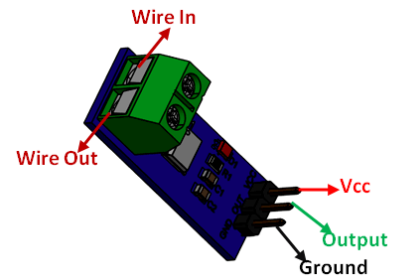

Figure 6.15 Typical Application Connection of ACS712

### Specifications

- Measures both AC and DC current
- Available as 5A, 20A and 30A module
- Provides isolation from the load
- Easy to integrate with MCU, since it outputs analog voltage

## **Working Principle**

- Current Sensor detects the current in a wire or conductor and generates a signal proportional to the detected current either in the form of analog voltage or digital output.
- current-carrying conductor also gives rise to a magnetic field in its surrounding. In Indirect Sensing, the current is measured by calculating this magnetic field by applying either Faraday's law or Ampere law. Here either a Transformer or Hall effect sensor or fiberoptic current sensor are used to sense the magnetic field.
- ACS712 Current Sensor uses Indirect Sensing method to calculate the current. To sense current a linear, low-offset Hall sensor circuit is used in this IC.
- The proximity of the magnetic signal to the Hall sensor decides the accuracy of the device. Nearer the magnetic signal higher the accuracy.

## **Features and Benefits**

- Low-noise analog signal path
- Device bandwidth is set via the new FILTER pin
- 5  $\mu$ s output rise time in response to step input current
- 80 kHz bandwidth
- Total output error 1.5% at TA = 25°C
- 1.2 m $\Omega$  internal conductor resistance
- 2.1 kV<sub>rms</sub> minimum isolation voltage from pins 1-4 to pins 5-8
- 5.0 V single supply operation
- 66 to 185 mV/A output sensitivity
- Output voltage proportional to AC or DC currents
- Nearly zero magnetic hysteresis

## **Applications of ACS712 Current Sensor**

- This IC can detect both AC and DC current so, it has a wide range of applications.
- ACS712 is used in many industrial, commercial and communication applications. This IC is applicable for Automobile applications. Some of the typical applications of this IC can be found in motor control circuits, for load detection and management, SMPS, overcurrent fault protection circuit.
- This IC can measure current for high voltage loads operating at 230V AC mains. To read the values it can be easily interfaced with the ADC of a microcontroller

## Interfacing with Arduino

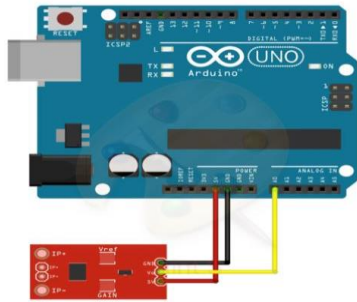

Figure 6.16 Connection Diagram of Interfacing of ACS712 with Arduino Uno

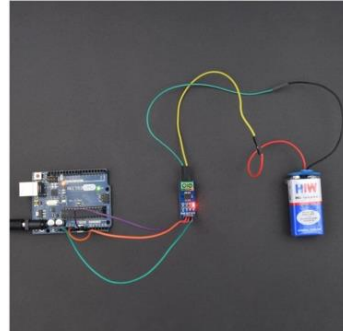

Figure 6.17 Image of ACS712 being Interfaced with Arduino Uno

### Code

```
#define CURRENT_SENSOR A0 // Define Analog input pin that sensor is attached

float amplitude_current; // Float amplitude current
float effective_value; // Float effective current

void setup()
{
  Serial.begin(9600);
  pins_init();
}
void loop()
{
  int sensor_max;
  sensor_max = getMaxValue();
  Serial.print("sensor_max = ");
  Serial.println(sensor_max);

  //the VCC on the Arduino interface of the sensor is 5v

  amplitude_current=(float)(sensor_max-512)/1024*5/185*1000000; // for 5A mode,you need to modify this with 20 A and 30A mode;
  effective_value=amplitude_current/1.414;

  //for minimum current=1/1024*5/185*1000000/1.414=18.7(mA)
  //Only sinusoidal alternating current

  Serial.println("The amplitude of the current is(in mA)");
  Serial.println(amplitude_current,1);

  //Only one number after the decimal point

  Serial.println("The effective value of the current is(in mA)");
  Serial.println(effective_value,1);
}
void pins_init()
{
  pinMode(CURRENT_SENSOR, INPUT);
}
/*Function: Sample for 1000ms and get the maximum value from the S pin*/

int getMaxValue()
{
  int sensorValue; //value read from the sensor
  int sensorMax = 0;
  uint32_t start_time = millis();
  while((millis()-start_time) < 1000) //sample for 1000ms
  {
    sensorValue = analogRead(CURRENT_SENSOR);
    if (sensorValue > sensorMax)
    {
      /*record the maximum sensor value*/

      sensorMax = sensorValue;
    }
  }
  return sensorMax;
}
```

## 6.2.4 Voltage Measurement Unit

In this project prototype for voltage measurement purpose we have used ZMPT101B Voltage sensor module.

### 6.2.4.1 ZMPT101B Voltage Sensor

Single-phase AC active output voltage mutual inductance module equipped with ZMPT101B series of a high-precision voltage transformer and high-precision op-amp current, easy to 250v within the AC power signal acquisition.

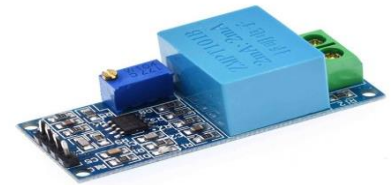

Figure 6.18 ZMPT101B Voltage Sensor Module

ZMPT101B voltage sensor module is a voltage sensor made

from the ZMPT101B voltage transformer. It has high accuracy, good consistency for voltage and power measurement and it can measure up to 250V AC. It is simple to use and comes with a multi turn trim potentiometer for adjusting the ADC output. Its most important characteristics would be,

- High galvanic isolation
- Wide Range
- High accuracy
- Good Consistency



Figure 6.19 ZMPT101B Voltage Transformer

ZMPT101B is a high precision voltage Transformer. This module makes it easy to monitor AC mains voltage up to 1000 volts. A tiny little thing the size of a bouillon cube. Holds up to 4kV per breakdown voltage, the ratio of turns is 1: 1, but this is a current transformer of 2mA: 2mA. That is, we feed it a current and remove the current. The input current is simply set by the resistor in series R1, and a sampling resistor R2 is used in parallel to obtain the output voltage

#### Feature of ZMPT101B Module

- within 250 V AC voltage can be measured.
- onboard micro-precision voltage transformer
- Installation: PCB mounting (Pin Length > 3mm)
- Operating temperature : 40°C ~ + 70°C



## Technical Specifications

Specifications	Descriptions
Rated input current	2mA
Rated output current	2mA
Linear range	0~1000V 0~10mA
Isolation withstand voltage	4000V
Turns Ratio	1000:1000
Measurement accuracy Class	0.2
Linearity	0.1%
Rated Burdon	$\leq 200\Omega$
Operating Frequency	50-50Hz
DC coil Resistance	110 @ 20°C

Table 6.4 Technical Specification of ZMPT101B

### Advantages

- Analog output corresponding quantity can be adjusted.
- PCB board size: 49.5 (mm) x19.4 (mm)
- Good consistency, for voltage and power measurement
- Very efficient and accuracy

### Applications

- Metering (electrical energy meters)
- AC Voltage measurement
- Sensing Overload Current
- Ground fault detection
- Household electrical equipment
- Industrial apparatuses
- Electrical testing equipment and relay protection

### Interfacing with Arduino

To measure AV voltage, we will need to have a ZMPT101B module. All we have to do is connect  $V_{cc}$  of the module to 5v of the Arduino GND to ground of the Arduino and  $V_{out}$  to analog pin 0 of the Arduino Uno. Once all the connections are made, we just need to upload the code to the Arduino and open the serial monitor and the voltage will be displayed. We can measure up to 300v with this module.

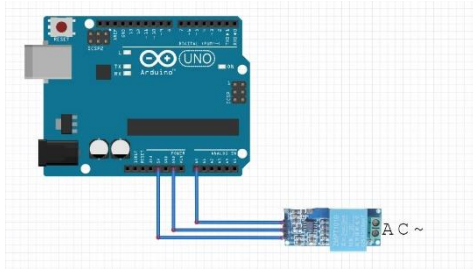

Figure 6.20 Connection Diagram of ZMPT101B with being Interfaced with Arduino Uno

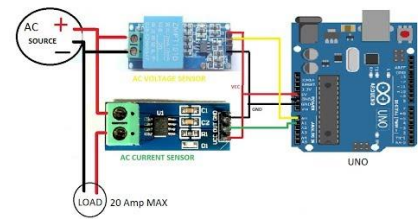

Figure 6.21 Connection Diagram of ZMPT101B along with ACS712 being Interfaced with Arduino Uno

## Code

```
#include "ZMPT101B.h"
#include "ACS712.h"

// ZMPT101B sensor connected to A0 pin of arduino
ZMPT101B voltageSensor(A0);

// 5 amps version sensor (ACS712_05B) connected to A1 pin of arduino
ACS712 currentSensor(ACS712_05B, A1);

void setup()
{
  Serial.begin(9600);

  // calibrate() method calibrates zero point of sensor,
  // It is not necessary, but may positively affect the accuracy
  // Ensure that no current flows through the sensor at this moment
  Serial.println("Calibrating... Ensure that no current flows through the sensor at this moment");
  delay(100);
  voltageSensor.calibrate();
  currentSensor.calibrate();
  Serial.println("Done!");
}

void loop()
{
  // To measure voltage/current we need to know the frequency of voltage/current
  // By default 50Hz is used, but you can specify desired frequency
  // as first argument to getVoltageAC and getCurrentAC() method, if necessary

  float U = voltageSensor.getVoltageAC();
  float I = currentSensor.getCurrentAC();

  // To calculate the power we need voltage multiplied by current
  float P = U * I;

  Serial.println(String("U = ") + U + " V");
  Serial.println(String("I = ") + I + " A");
  Serial.println(String("P = ") + P + " Watts");

  delay(1000);
}
```

## 6.2.5 Frequency Measurement Unit

Frequency is number of cycles (complete turns) per 1 second. Its main unit of measurement is Hertz (Hz). Period is time required to complete 1 cycle (turn), its main unit is second. Frequency = 1/Period. Home alternating current (AC) frequency is 50. For frequency of 50Hz the period is 20 milliseconds. The AC input is connected to the circuit as shown where diode 1N4007 is used to eliminate negative half cycles because the PC817 optocoupler maximum reverse voltage is 6V. The

optocoupler is connected to AC main through 120k ohm resistor (and also the 1N4007 diode) which limits the current that passes through the optocoupler LED ( $I_F$ ). With the 120k ohm resistor and with source of 220V, the peak forward current is equal to (neglecting diode voltages):  $220 \times \sqrt{2} / 120k = 2.59$  mA and the RMS current (half wave) =  $2.59/2 = 1.3$  mA.

## Interfacing with Arduino

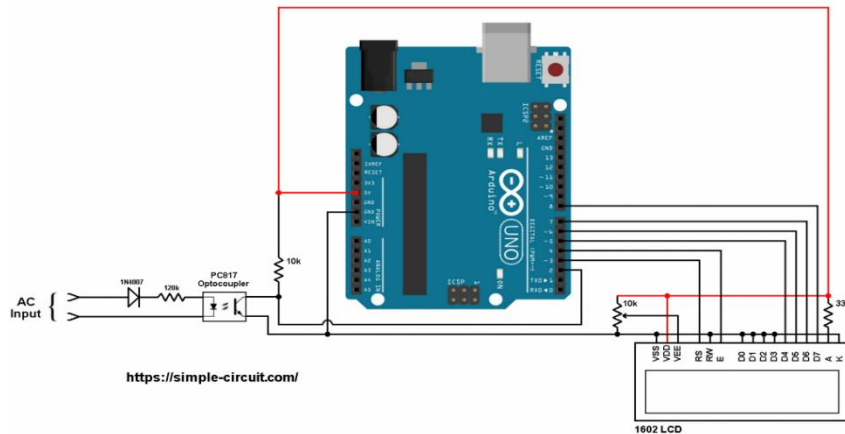

Figure 6.22 Interfacing of Frequency Measurement Circuit with Arduino Uno

The output of the PC817 optocoupler is connected to the Arduino as follows:

The emitter is connected to Arduino GND, The collector is connected to Arduino digital pin 2.

This pin is also for external interrupt 0. The collector is connected to Arduino +5V pin through pull up resistor of 10k ohm. In this project I used external interrupt 0 to detect falling (going from high to low) of the optocoupler output. This interrupt is initialized as shown below, -

```
EIFR |= 1; // clear INT0 flag
attachInterrupt(0, timer1_get, FALLING); // enable external interrupt (INT0)
```

When there is an interrupt the Arduino directly executes the function `timer1_get()` Measuring the frequency idea is simple, Timer1 module is used to measure time between 2 successive interrupts which means we have the time between 2 successive falling events. When the function `timer1_get()` is called, it stores Timer1 value on a variable named: `tmr1`. Timer1 module is configured to increment by 2 every 1 microsecond (prescaler = 8) and its overflow interrupt is enabled in order to reset the variable `tmr1` (helps when signal is removed). With prescaler = 8, the clock input of Timer1 module is equal to:  $\text{Timer1\_CLK} = 16\text{MHz}/8 = 2\text{MHz}$ . With these configurations the lowest frequency that the Arduino can measure is about 31Hz.

## Signal period:

Period (in  $\mu\text{s}$ ) =  $\text{Timer1\_Value}/\text{Timer1\_CLK} = \text{Timer1\_Value}/16000000/8$

Period(in  $\mu\text{s}$ ) =  $8 \times \text{Timer1\_Value}/16000000$

Period (in ms) =  $8 \times \text{Timer1\_Value}/16000$

## Signal frequency:

Frequency =  $1/\text{Period}$

Frequency (in Hz) =  $16000000/(8 \times \text{Timer1\_Value})$

## Code

```
#include <LiquidCrystal.h> // include Arduino LCD library

// LCD module connections (RS, E, D4, D5, D6, D7)
LiquidCrystal lcd(3, 4, 5, 6, 7, 8);

void setup(void) {

  lcd.begin(16, 2); // set up the LCD's number of columns and rows
  lcd.setCursor(0, 0);
  lcd.print("Freq =");
  lcd.setCursor(0, 1);
  lcd.print("Peri =");

  // Timer1 module configuration
  TCCR1A = 0;
  TCCR1B = 2; // enable Timer1 module with 1/8 prescaler ( 2 ticks every 1 us)
  TCNT1 = 0; // Set Timer1 preload value to 0 (reset)
  TIMSK1 = 1; // enable Timer1 overflow interrupt

  EIFR |= 1; // clear INT0 flag
  attachInterrupt(0, timer1_get, FALLING); // enable external interrupt (INT0)
}

uint16_t tmr1 = 0;
float period, frequency;

void timer1_get() {
  tmr1 = TCNT1;
  TCNT1 = 0; // reset Timer1
}

ISR(TIMER1_OVF_vect) { // Timer1 interrupt service routine (ISR)
  tmr1 = 0;
}

// main loop
void loop() {

  // save current Timer1 value
  uint16_t value = tmr1;
  // calculate signal period in milliseconds
  // 8.0 is Timer1 prescaler and 16000 = MCU_CLK/1000
  period = 8.0 * value/16000;
  // calculate signal frequency which is = 1/period ; or = MCU_CLK/(Prescaler * Timer_Value)
  if(value == 0)
    frequency = 0; // avoid division by zero
  else
    frequency = 16000000.0/(8UL*value);

  lcd.setCursor(7, 0);
  lcd.print(frequency);
  lcd.print(" Hz ");
  // print period
  lcd.setCursor(7, 1);
  lcd.print(period);
  lcd.print(" ms ");

  delay(500);
}
```

## Result

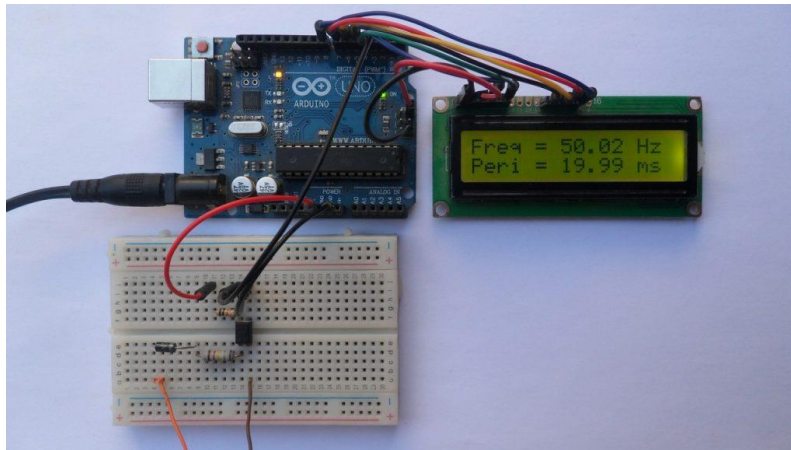

Figure 6.23 Frequency Measurement Result

### 6.2.6 Temperature Measurement Unit

Here in this prototype demonstration we have used LM35 temperature sensor for temperature measurement purpose.

#### 6.2.6.1 LM 35 Temperature Sensor

LM35 is a temperature sensor that outputs an analog signal which is proportional to the instantaneous temperature. The output voltage can easily be interpreted to obtain a temperature reading in Celsius. The advantage of lm35 over thermistor is it does not require any external calibration. The coating also protects it from self-heating. Low cost and greater accuracy.

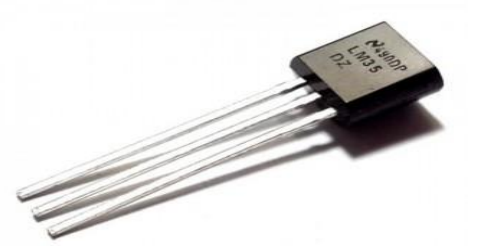
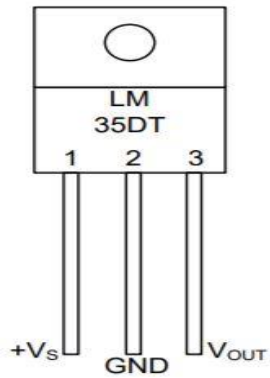

Figure 6.24 LM35 Temperature Sensor

LM35 can measure from -55 degrees centigrade to 150-degree centigrade. The accuracy level is very high if operated at optimal temperature and humidity levels. The conversion of the output voltage to centigrade is also easy and straight forward. The input voltage to LM35 can be from +4 volts to 30 volts. It consumes about 60 microamperes of current.

## Pin Diagram of LM 35



Pin No.	Pin Name	Description
1	Vcc	Input voltage is +5V for typical applications
2	Analog Out	There will be increase in 10mV for raise of every 1°C. Can range from -1V(-55°C) to 6V(150°C)
3	Ground	Connected to ground of circuit

Figure 6.25 Pin Diagram of LM 35 Temperature Sensor

Table 6.5 Pin Details of LM 35 Sensor

## Features

- Calibrated Directly in Celsius (Centigrade)
- Linear + 10-mV/°C Scale Factor
- 0.5°C Ensured Accuracy (at 25°C)
- Rated for Full -55°C to 150°C Range
- Suitable for Remote Applications
- Operates from 4 V to 30 V
- Less than 60-μA Current Drain
- Low Self-Heating, 0.08°C in Still Air
- Non-Linearity Only  $\pm\frac{1}{4}$ °C Typical
- Low-Impedance Output, 0.1  $\Omega$  for 1-mA Load

## Interfacing with Arduino

Here, LM35 output is given to analog pin A1 of Arduino UNO. This analog voltage is converted to its digital form and processed to get the temperature reading

## Code

```
const int lm35_pin = A1; /* LM35 O/P pin */

void setup() {
  Serial.begin(9600);
}

void loop() {
  int temp_adc_val;
  float temp_val;
```

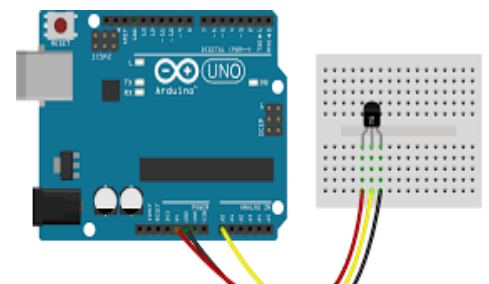

Figure 6.26 Interfacing of LM35 Sensor with Arduino Uno

```

temp_adc_val = analogRead(lm35_pin); /* Read Temperature */
temp_val = (temp_adc_val * 4.88); /* Convert adc value to equivalent voltage */
temp_val = (temp_val/10); /* LM35 gives output of 10mv/°C */
Serial.print("Temperature = ");
Serial.print(temp_val);
Serial.print(" Degree Celsius\n");
delay(1000);
}

```

## 6.2.7 Protection Unit

It consists of a relay module and a piezo buzzer.

### 6.2.7.1 Relay Module

A relay is basically a switch which is operated by an electromagnet. The electromagnet requires a small voltage to get activated which we will give from the Arduino and once it is activated, it will pull the contact to make the high voltage circuit. The relay module we are going to use is the SRD-05VDC-SL-C. It runs on 5V and we can control it with any micro-controller but we are going to use Arduino.



Figure 6.27 Relay Module

Typically, the relay has 5 pins, three of them are high voltage terminals (NC, COM, and NO) that connect to the device we want to control. The mains electricity enters the relay at the common (COM) terminal. While use of NC & NO terminals depends upon whether you want to turn the device ON or OFF. Between the remaining two

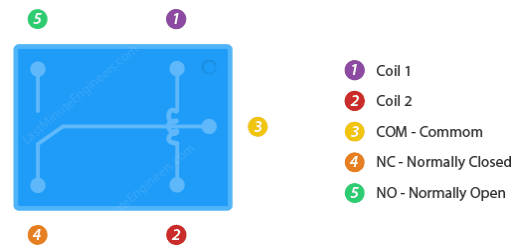

Figure 6.28 Single Cube Relay

pins (coil1 and coil2), there is a coil that acts like an electromagnet. When current flows through the coil, the electromagnet becomes charged and moves the internal contacts of the switch. At that time the normally open (NO) terminal connects to the common (COM), and the normally closed (NC) terminal becomes disconnected. When current stops flowing through the coil, the internal contact returns to its initial state i.e. the normally closed (NC) terminal connects to the common (COM), and the normally open (NO) terminal reopens. This is known as a single pole, double throw switch (SPDT).

In this prototype demonstration we are going to use two channel relay modules. However, there are other modules with one, four and eight channels. This module is designed for switching two high powered devices from your Arduino. It has two relays rated up to 10A per channel at 250VAC or 30VDC. There are two LEDs on the relay module indicating the position of the relay. Whenever a relay is activated, the respective LED will light up. One of the best things about these modules

is that they come with two Optocoupler ICs which provide good isolation between relay and Arduino.

### Two Channel Relay Module Pinout

- **Control Pins:**

V<sub>cc</sub> pin supplies power to the built-in optocoupler and optionally to the electromagnet of the relay (if you keep the jumper in place)

GND is the common Ground connection.

IN<sub>1</sub> & IN<sub>2</sub> pins are used to control the relay. These are active low pins, meaning the relay will be activated when you pull the pin LOW and it will become inactive when you pull the pin HIGH.

- **Power Supply Selection Pins:**

JD-V<sub>cc</sub> supplies power to the electromagnet of the relay. When the jumper is in place, it takes power from the Arduino's 5V line. Without the jumper cap, you have to connect it to an independent power source.

V<sub>cc</sub> with the jumper cap on, this pin is shorted to the JD-VCC pin. If you remove the jumper, keep this pin unconnected.

GND is the common Ground connection.

- **Output Terminals:**

COM pin is connected to the signal you are planning to switch.

NC pin is connected to the COM pin by default, unless you send a signal from the Arduino to the relay module to break the connection.

NO pin is open by default, unless you send a signal from the Arduino to the relay module to make the connection.

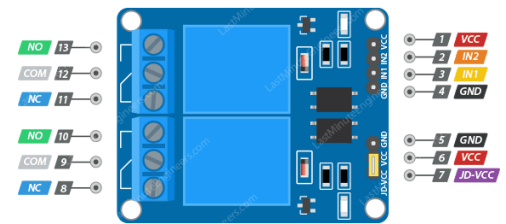

Figure 6.29 Two Channel Relay Module Pinout

### Interfacing with Arduino Uno

For the control of AC device, you need to take the necessary precautions because the AC is dangerous and it can cause damage to you. So, to avoid any danger, follow the below tutorial correctly. For the control of AC device, we will require an external source which will power the AC source. So, connect the VCC, ground and signal to the 5V, ground and pin 8 of Arduino respectively. On the other end, connect one wire of the AC source to the one

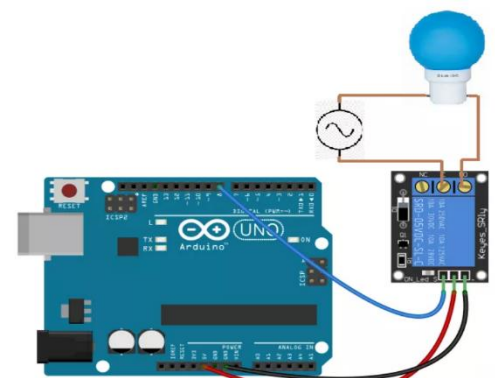

Figure 6.30 Interfacing of Relay Module with Arduino



end of the bulb and the other wire to the common (C) of the relay. Then connect the normally open (NO) to the other end of the bulb.

### Code

```
int relay_pin = 8;
void setup(){
  pinMode(relay_pin,OUTPUT);
}
void loop(){
  digitalWrite(relay_pin,HIGH);
  delay(5000);
  digitalWrite(relay_pin,LOW);
  delay(5000);
}
```

### 6.2.7.2 Piezo Buzzer

The piezo buzzer produces sound based on reverse of the piezoelectric effect. The generation of pressure variation or strain by the application of electric potential across a piezoelectric material is the underlying principle. These buzzers can be used alert a user of an event corresponding to a switching action, counter signal or sensor input. They are also used in alarm circuits. The buzzer produces a same noisy sound irrespective of the voltage variation applied to it. It consists of piezo crystals between two conductors. When a potential is applied across these crystals, they push on one conductor and pull on the other. This, push and pull action, results in a sound wave. Most buzzers produce sound in the range of 2 to 4 kHz. The +ve lead is connected to the Input and the -ve lead is connected to Ground. Piezo buzzers generally use less current, have a higher sound output and wider operating voltage. However, electro-magnetic buzzers are capable of producing sound at low frequencies in small, compact housings.



Figure 6.31 Piezo buzzer

### Interfacing with Arduino Uno

Here `tone(buzzer, 1000)` sends a 1KHz sound signal to pin 9, `delay(1000)` pause the program for one second and `noTone(buzzer)` stops the signal sound. The `loop()` routine will make this run again and again making a short beeping sound. we can also use `tone(pin, frequency, duration)` function.

### Code

```
const int buzzer = 9; //buzzer to arduino pin 9
```

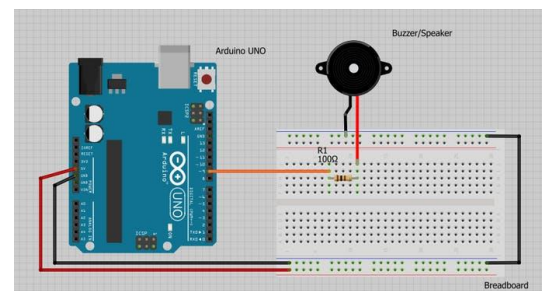

Figure 6.32 Interfacing of Piezo buzzer with Arduino Uno

```

void setup(){
  pinMode(buzzer, OUTPUT); // Set buzzer - pin 9 as an output
}
void loop(){
  tone(buzzer, 1000); // Send 1KHz sound signal...
  delay(1000); // ...for 1 sec
  noTone(buzzer); // Stop sound...
  delay(1000); // ...for 1sec
}

```

## 6.2.8 Display Unit

### 6.2.8.1 16 \*2 Display

An LCD is an electronic display module which uses liquid crystal to produce a visible image. The 16×2 translates o a display 16 characters per line in 2 such lines. In this LCD each character is displayed in a 5×7-pixel matrix.

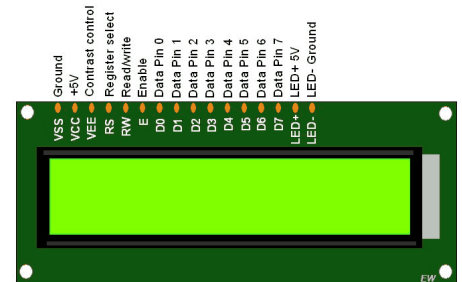

Figure 6.33 16\*2 LCD Module

#### Pin Details of 16\*2 Display

Sl. No.	Pin No.	Pin Name	Pin Type	Pin Description	Pin Connection
1	Pin 1	GND	Source Pin	This is the ground pin of LCD	Connected to the ground of the MCU
2	Pin 2	VCC	Source Pin	This is the supply voltage pin of LCD	Connected to the supply pin
3	Pin 3	V0/VEE	Control Pin	Adjusts the contrast of the LCD	Connected to a variable POT that can source 0-5 V
4	Pin 4	Register Select	Control Pin	Toggles between Command/Register	Connected to a MCU pin and gets either 0 for command mode or 1 for data mode
5	Pin 5	Read/Write	Control Pin	Toggles the LCD between Read/Write Operation	Connected to a MCU pin and gets either 0 for write or 1 for read
6	Pin 6	Enable	Control Pin	Must be high to perform Read/Write Operation	Connected to a MCU pin and always held high
7	Pin 7 - 14	Data Bits (0-7)	Data/Command Pin	This pin used to send command or data to the LCD	In 4 wire mode (0-3) is connected and in 8 wire mode (0-7) is connected to MCU
8	Pin 15	LED Positive	LED Pin	Normal LED like operation to illuminate the LCD	Connected to +5 V
9	Pin 16	LED Negative	LED Pin	Normal LED like operation to illuminate the LCD	Connected to GND

#### Features of LCD16x2

The features of this LCD mainly include the following.

- The operating voltage of this LCD is 4.7V-5.3V
- It includes two rows where each row can produce 16-characters.
- The utilization of current is 1mA with no backlight
- Every character can be built with a 5×8 pixel box
- The alphanumeric LCDs alphabets & numbers

- Is display can work on two modes like 4-bit & 8-bit
- These are obtainable in Blue & Green Backlight
- It displays a few custom generated characters

### Registers of LCD

A 16×2 LCD has two registers like data register and command register. The RS (register select) is mainly used to change from one register to another. When the register set is '0', then it is known as command register. Similarly, when the register set is '1', then it is known as data register.

- **Command Register**

The main function of the command register is to store the instructions of command which are given to the display. So that predefined tasks can be performed such as clearing the display, initializing, set the cursor place, and display control. Here commands processing can occur within the register.

- **Data Register**

The main function of the data register is to store the information which is to be exhibited on the LCD screen. Here, the ASCII value of the character is the information which is to be exhibited on the screen of LCD. Whenever we send the information to LCD, it transmits to the data register, and then the process will be starting there. When register set =1, then the data register will be selected

### Interfacing with Arduino

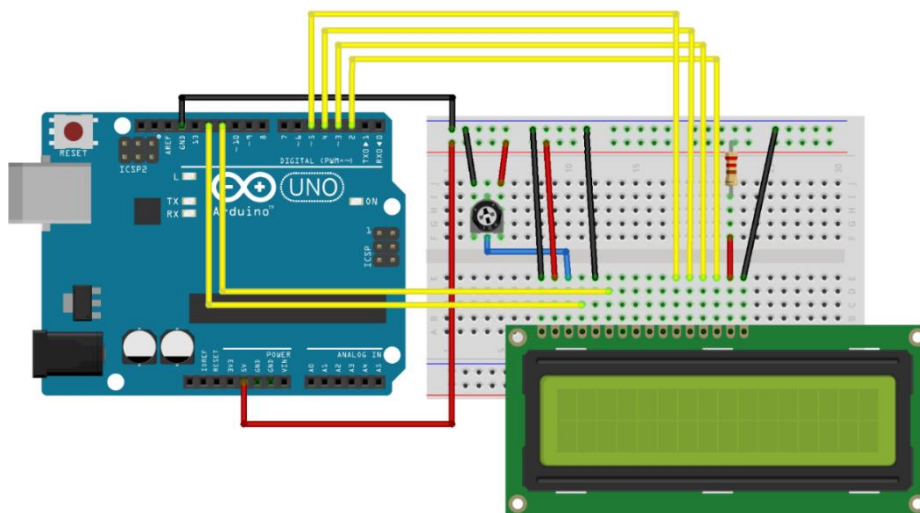

Figure 6.34 Interfacing of 16\*2 LCD Module with Arduino Uno

### code

```
// include the library code:
#include <LiquidCrystal.h>

// initialize the library with the numbers of the interface pins
LiquidCrystal lcd(12, 11, 5, 4, 3, 2);

void setup() {
```

```

// set up the LCD's number of columns and rows:
lcd.begin(16, 2);
// Print a message to the LCD.
lcd.print("hello, world!");
}

void loop() {
// set the cursor to column 0, line 1
// (note: line 1 is the second row, since counting begins with 0):
lcd.setCursor(0, 1);
// print the number of seconds since reset:
lcd.print(millis() / 1000);
}

```

## 6.3 DIAGRAMS

### 6.3.1 Circuit Diagram of the Prototype

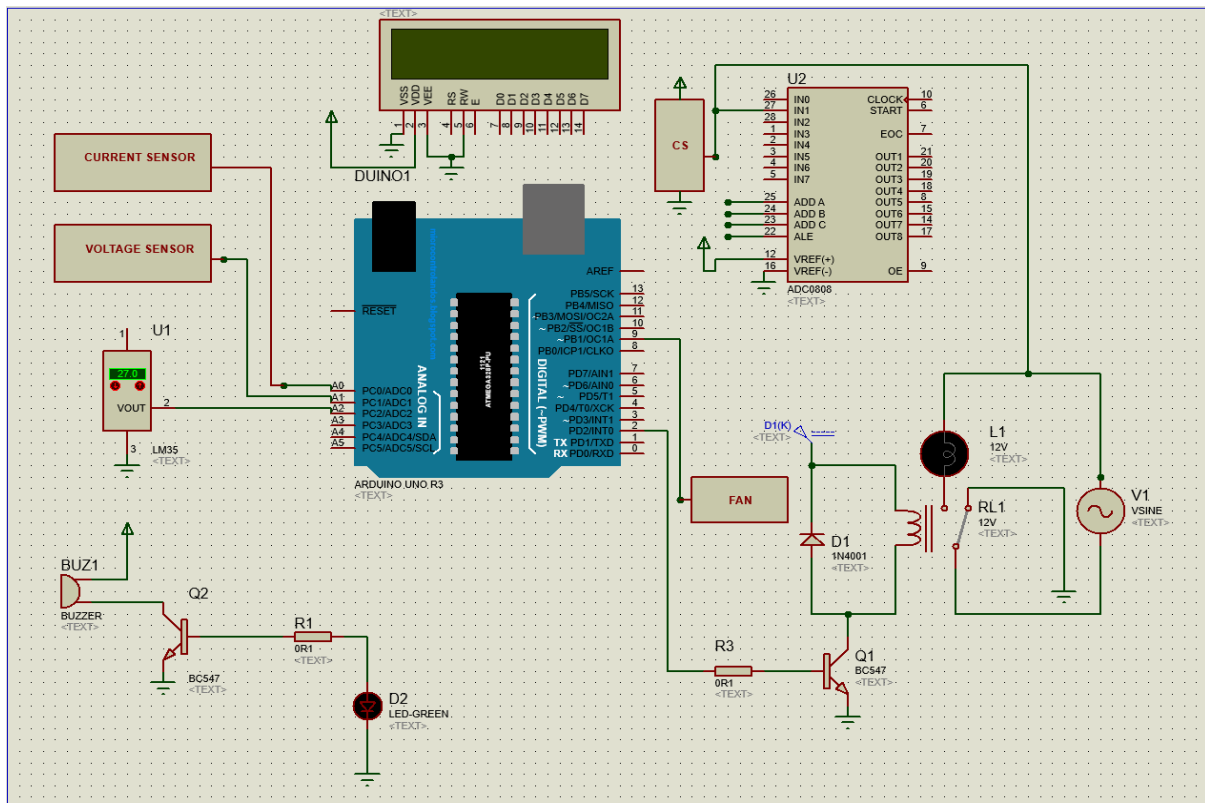

### 6.3.2 Flow Diagram of the Prototype

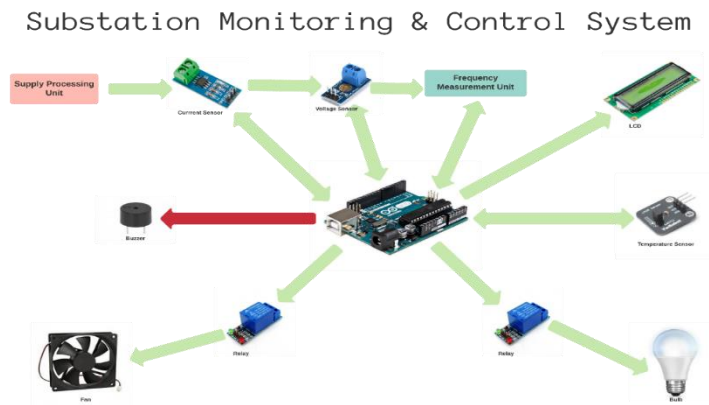

Here in the proposed prototype we have used Arduino Uno as our primary microcontroller. It will work as the heart of the system; all other measurement circuitries will be interfaced through this. Besides the microcontroller we have used ACS712 current sensor, ZMPT101B voltage sensor, LM 35 temperature sensor, frequency measurement unit, a piezo buzzer and a two-channel relay module; and to demonstrate the load we have used a fan and a bulb. Alongside we also have used a supply unit, consisting of a transformer, which converts 230 Volt AC to 12 Volt AC then it is passed through bridge rectifier unit which converts this 12 Volt AC to 12 Volt DC which is pulsating in nature which is then fed to the capacitor which work as a filter, makes the pulsating DC to smooth DC. As a lot of our components like Arduino Uno and some of the sensors as well require 5 Volt regulated DC, that is why this 12 Volt DC is fed to 7805 Voltage regulator which makes it to 5 Volt regulated DC. In case of buzzer and relay need high amount of current for operation, we have to make some arrangements for that. For that amplification arrangement in case of relay we have used a relay driver and for buzzer we have used two BC 547 transistor in Darlington pair configuration. For operation of the green and red LEDs which work as an indicator they also need large amount of current for their amplified current requirement we have used two BC 547 transistors one for each.

When we give supply to our prototype the display shows a welcome message and simultaneously all the sensor start sensing the current, voltage, frequency and temperature and update all the real time values to the server as well as shows on the display. It compares all the real time values with the pre-defined values, if any of the values exceeds pre-defined values it sends a fault alert to the relay and buzzer as well as update it on the display. If the fault exists for the pre-set time then relay isolates the loads from the rest of the system. In the meantime, comparison goes on as before, if the fault gets cleared relays reconnect the loads with the rest of the system.

# CHAPTER 7

(CONCLUSION & FUTURE WORK)

## **7.1 ADVANTAGES OF THE PROJECT**

### **Helpful for Fault Management**

Monitoring means acquiring parameters from the assets of interest. The data obtained is of great importance for fault management and scheduled maintenance. By promoting modern and competitive techniques and equipment for continuous monitoring and diagnosis, it is possible to track natural or accidental degradation over time; if identified in time and remedied, it will not generate serious events which may be sources of extremely costly damage for electricity suppliers and consumers. At the same time, it is possible to extend the life of the equipment, optimize the maintenance program, and reduce the outages and expenses for the planned repairs of the facility.

### **Reduced hazards**

This method minimizes time contact between human and high voltage device. As it is known, most substation devices have high voltage and generate electromagnetic that can harm human health. On the other hand, the exposure to high voltage environment may also be able to cause risk to human health. Therefore, an integrated monitoring system is crucial to be implemented for easy monitoring and controlling the substation while minimizing interaction of human to the substation devices.

### **Real time monitoring**

This is one of the main perspectives why we have chosen this project in the first place. In most of the today's facilities lack in this point, because they don't have proper facility to fetch real time data; they usually rely on the periodically collected data that too manually collected. Thereby it is very tough sometimes to judge the actual health of the machine we are monitoring. What has been overcome through this project. Here we are able to monitor the real time data of the machine irrespective of fault.

### **Remote Access**

This is one of the main advantages of this project. All the real time data collected by WSN are being updated to the server, which enables us to get all the real time data at its ease remotely. Which means we do not need to go the control room to physically check the data.

### **Periodical collection of data**

Now a days in most of the power facilities the work personnel responsible for collection of data go to the control room and physically jot down all the data and then after coming back again updates all those to the data sheets which is a lot more time consuming. But through our project all these could be done in a matter of seconds. All the real time data being collected will be stored in a external memory periodically. Although as of now we have not included any sort of external memory in our prototype, for demonstration purpose we have used the microcontroller memory only.

### **Error free data**

As we already have discussed by now that data in the power facilities are mostly collected manually, which are error prone. And most importantly we do not get all the data at a single sync because manual collection

of data will involve delay to some extent i.e., values of all the machines are not of same time instant, which doesn't matter that much if the facility is smaller, but just imagine the scenario in case of a large power facility where a person need to take hundreds of values there this delay is considerable. Here the data will be error free as we have eliminated any manual involvement in case of data collection.

### **Personalised alert over fault**

By incorporating this project, we can get Personalised alerts over any sort of discrepancies i.e., whenever the electrical parameters exceed the predefined values. We have incorporated relays which acts over and physically isolates the machines where disturbances occur.

### **Cost Effective**

After incorporating this project, we do not need to deploy person at every place for collection data, this reduction of manual force reduces the labour cost to some extent. The sensors and transducers employed also does not need regular maintenance which in turn reduces the maintenance cost. That means overall labour cost is reduced.

## **7.2 ACHIEVEMENTS OF THE PROJECT**

The achievement of the substation monitoring system allows the following:

- To provide operative and relevant data necessary for the proper integration of transformer substations into the local and central network;
- To provide useful information necessary for the maintenance optimization in transformer substation equipment;
- To improve the safe operation of all equipment;
- To extend the lifespan of the dedicated equipment and increase the safety of electric power transmission with consequences for end-users

## **7.3 CONCLUSION**

Monitoring means acquiring significant parameters from the assets of interest. The acquired data is feasible to be used for analyses and diagnose the condition of the assets which is of great use for maintenance scheduling, failure management and controlling system and this method minimizes time contact between human and high voltage device. As it is known, most substation devices have high voltage and generate electromagnetic that can harm human health. This proposed system is specially designed for monitoring the condition of substation transformers which are deployed at dispersed locations There are many parameters to be quantified and monitored periodically It is quite costly and difficult to monitor the parameters by appointing a person at all locations and furthermore the data would also be error prone if the monitoring is manual. The greatest issue is to have all the transformers data at a single sink when the data is collected manually. Through our proposed system all the problems discussed above can be reduced to some great extent.



## **7.4 FUTURE SCOPE**

### **Addition of GSM Module**

By incorporating the GSM module, we will be able to send Personalised SMS to the authorities so that they can remain be updated about the plant while outside. And the microcontroller is programmed in such a way that a particular format of SMS is send which can be used as a input for the microcontroller for required operation.

### **Addition of Wireless Camera**

We can install wireless cameras in the premises of substation switchyard; through we shall be able to visually monitor the substation in a better way. This particular would be really helpful for monitoring of transformers as we know most of the time they are deployed in the dispersed locations.

### **Development of GUI**

The window display is developed using Graphical User Interface (GUI). The devices and their parameters such as frequency, voltage, load impedance, reluctance, oil level, temperature, cooling condition and power can be monitored integratedly in a displayer. This method helps the operator monitoring in real time the condition of each device easily. Furthermore, in the case of any failure, the operator will be acknowledged immediately that a specific device is experiencing some difficulty or failure. The blackout condition can be prevented and continuity power supply will be guaranteed.

### **Coolant Management System**

We can add a coolant management system along with the temperature sensor module; which will be very helpful for the managing cooling flow and temperature management. It can be designed in such a way when the temperature of a module or a particular equipment will exceed a predefined limit the coolant flow will be rapid and continuous, and when temperature is well within range then the coolant flow will be slow and periodic.

# REFERENCES

- [1] J. L. Velásquez, R. Villafáfila-Robles, P. Lloret, L. Molas-Balada, A. Sumper, S. Galceran-Arellano, A. Sudrià-Andreu, Oct. 2007, "Development and implementation of a condition monitoring system in a substation", 9th International Conference on Electrical Power Quality and Utilisation, EPQU 2007
- [2] P. Lloret, J. L. Velásquez, L. Molas-Balada, R. Villafáfila-Robles, A. Sumper, S. Galceran-Arellano, Oct. 2007, "IEC 61850 as a flexible tool for electrical systems monitoring", 9th International Conference on Electrical Power Quality and Utilisation, EPQU 2007
- [3] D. Sacerdoțianu, I. Hurezeanu, A. Marinescu, Gh. Manolea and I.Purcaru, "Modern Equipment for Monitoring and Diagnosis of Transformer Substations, Implemented in Electric Retechnologized Substations in Romania", 3rd International Conference on Modern Power Systems MPS 2010, 18-21May 2010,Cluj-Napoca, Romania
- [4] D. Pal, R. Meyur, S. Menon; M.J.B. Reddy; D.K. Moha, "Real-time condition monitoring of substation equipment using thermal cameras", Published in: IET Generation, Transmission & Distribution, (Volume: 12, Issue: 4, 2 27, 2018)
- [5] D. Hanafi, M.N. Ribuan, I.A. Wibowo, H. Hashim, M.I. Ismail "Simulation of substation integrated monitoring system using LabVIEW", Transaction on Power System Distribution, ISSN: 2229-8711 Online Publication, June 2011.
- [6] J. Singh, Y. R. Sood, R. K. Jarial and P. Verma, "Condition Monitoring of Power Transformers", Bibliography Survey, vol. 24, no. 3, pp. 11-25, 2008.
- [7] Dr.P.B.Pankajavalli, Mr.G.S.Karthick, Mr.M.Sridhar, Mr.A.Muniyappan, "A System for Monitoring the Electricity Sub-Station using Internet of Things", International Journal of Advance Research in Science & Engineering, Volume No. 6, Issue No. 12, December 2017
- [8] Mr. S. S. Ghodhade, Dhiraj D. Patil, Ajay kumar, S. Pujari, Sachin S. Ayarekar, Prakash B. Bandgar, Ashwini S. Waghmare, "Substation Monitoring and Control System", International Journal of Scientific Research and Review, Volume 7, Issue 3, 2018, ISSN NO: 2279-543X
- [9] Amol Ram Kate, Girish Baban Dongare, Krishana Maroti Janwade, Payal Burande, Narendra P. Zinjad, "Substation Monitoring System", International Journal for Research in Applied Science & Engineering Technology (IJRASET), ISSN: 2321-9653; IC Value: 45.98; SJ Impact Factor: 6.887 Volume 6 Issue V, May 2018- Available at [www.ijraset.com](http://www.ijraset.com)
- [10] Amit Sachan, "Microcontroller based substation monitoring and control system with GSM modem" ISSN: 2278-1676 Volume 1, Issue 6 (July-Aug. 2012), PP 13-21
- [11] Dr. Ghous Buksh Narejo, Engr. Shahyan Pervez Bharucha, Engr. Danny Zarir Pohwala, "Remote Microcontroller Based Monitoring of Substation and Control System through GSM Modem", International Journal of Scientific & Engineering Research, Volume 6, Issue 1, January-2015 714 ISSN 2229-5518 IJSER © 2015 <http://www.ijser.org>
- [12] Substation Automation for the Smart Grid, white paper, Cisco.
- [13] Dumitru SACERDOȚIANU, Florica LĂZĂRESCU, Iulian HUREZEANU, Ancuța-Mihaela ACIU, Marcel NICOLA, Ion PURCARU, Anca ALBIȚA, "Contributions to monitoring the condition of substations", 2019 8th International Conference on Modern Power Systems (MPS)
- [14] <https://www.edgefx.in/gsm-based-projects-on-substation-control-system-for-eee-students/>
- [15] [https://en.wikipedia.org/wiki/IEC\\_61850](https://en.wikipedia.org/wiki/IEC_61850)
- [16] [www.arduino.cc](http://www.arduino.cc)
- [17] <http://www.fritzing.org/home>

**APPENDIX A**  
**(SOFTWARE CODE)**

```

#include <ZMPT101B.h>
#include <ACS712.h>
#include <LiquidCrystal.h> // include Arduino LCD library
// ZMPT101B sensor connected to A0 pin of arduino
ZMPT101B voltageSensor(A0);
// 5 amps version sensor (ACS712_05B) connected to A1 pin of arduino
ACS712 currentSensor(ACS712_05B, A1);
// LCD module connections (RS, E, D4, D5, D6, D7)
LiquidCrystal lcd(3, 4, 5, 6, 7, 8);
const int lm35_pin = A2; /* LM35 O/P pin */
int relay_pin = 8;
const int buzzer = 9; //buzzer to arduino pin 9
void setup()
{
  Serial.begin(9600);
  // calibrate() method calibrates zero point of sensor,
  // It is not necessary, but may positively affect the accuracy
  // Ensure that no current flows through the sensor at this moment
  Serial.println("Calibrating... Ensure that no current flows through the sensor at this moment");
  delay(100);
  voltageSensor.calibrate();
  currentSensor.calibrate();
  Serial.println("Welcome to Substation Monitoring & Control System");
  lcd.begin(16, 2); // set up the LCD's number of columns and rows
  lcd.setCursor(0, 0);
  lcd.print("Freq =");
  lcd.setCursor(0, 1);
  lcd.print("Peri =");
  // Timer1 module configuration
  TCCR1A = 0;
  TCCR1B = 2; // enable Timer1 module with 1/8 prescaler ( 2 ticks every 1 us)
  TCNT1 = 0; // Set Timer1 preload value to 0 (reset)
  TIMSK1 = 1; // enable Timer1 overflow interrupt
  EIFR |= 1; // clear INTO0 flag
  attachInterrupt(0, timer1_get, FALLING); // enable external interrupt (INT0)
  pinMode(relay_pin,OUTPUT);
  pinMode(buzzer, OUTPUT); // Set buzzer - pin 9 as an output
}
void loop()
{
  // To measure voltage/current we need to know the frequency of voltage/current
  // By default 50Hz is used, but you can specify desired frequency
  // as first argument to getVoltageAC and getCurrentAC() method, if necessary
  float U = voltageSensor.getVoltageAC();
  float I = currentSensor.getCurrentAC();
  // To calculate the power we need voltage multiplied by current
  float P = U * I;
  Serial.println(String("U = ") + U + " V");
  Serial.println(String("I = ") + I + " A");
  Serial.println(String("P = ") + P + " Watts");
  delay(1000);
  // save current Timer1 value
  uint16_t value = tmr1;
}

```

```

// calculate signal period in milliseconds
// 8.0 is Timer1 prescaler and 16000 = MCU_CLK/1000
period = 8.0 * value/16000;
// calculate signal frequency which is = 1/period ; or = MCU_CLK/(Prescaler * Timer_Value)
if(value == 0)
frequency = 0; // avoid division by zero
else
frequency = 16000000.0/(8UL*value);
lcd.setCursor(7, 0);
lcd.print(frequency);
lcd.print(" Hz ");
// print period
lcd.setCursor(7, 1);
lcd.print(period);
lcd.print(" ms ");
delay(500);
int temp_adc_val;
float temp_val;
temp_adc_val = analogRead(lm35_pin); /* Read Temperature */
temp_val = (temp_adc_val * 4.88); /* Convert adc value to equivalent voltage */
temp_val = (temp_val/10); /* LM35 gives output of 10mv/°C */
Serial.print("Temperature = ");
Serial.print(temp_val);
Serial.print(" Degree Celsius\n");
delay(1000);
digitalWrite(relay_pin,HIGH);
delay(5000);
digitalWrite(relay_pin,LOW);
delay(5000);
tone(buzzer, 1000); // Send 1KHz sound signal...
delay(1000); // ...for 1 sec
noTone(buzzer); // Stop sound...
delay(1000); // ...for 1sec
}

```