

# **PC CONTROLLED SECURE LOAD SWITCHING USING MICROCONTROLLER**

*A Project report submitted in partial fulfillment  
of the requirements for the degree of B. Tech in Electrical Engineering*

by

**ANKITA BANERJEE (11701617073)  
ABHISHEK KUMAR MISHRA (11701617077)  
DIPANKAR BISWAS (11701617063)  
SAIKAT MONDAL (11701617043)**

*Under the supervision of*

**Mr. Budhaditya Biswas  
Assistant Professor  
Department of Electrical Engineering**



Department of Electrical Engineering  
**RCC INSTITUTE OF INFORMATION TECHNOLOGY**  
CANAL SOUTH ROAD, BELIAGHATA, KOLKATA – 700015, WEST BENGAL  
Maulana Abul Kalam Azad University of Technology (MAKAUT)  
© 2021

# PROTECT YOURSELF



WEAR PROTECTIVE  
MASK



WEAR GLOVE



KEEP DISTANCE  
FROM SICK PEOPLE



WASH HANDS  
FREQUENTLY



AVOID CROWD  
PLACES



AVOID  
CONTAMINATED  
OBJECTS



Department of Electrical Engineering  
**RCC INSTITUTE OF INFORMATION TECHNOLOGY**  
CANAL SOUTH ROAD, BELIAGHATA, KOLKATA – 700015, WEST BENGAL  
PHONE: 033-2323-2463-154, FAX: 033-2323-4668  
Email: hodeercciit@gmail.com, Website: <http://www.rcciit.org/academic/ee.aspx>

# CERTIFICATE

## To whom it may concern

This is to certify that the project work entitled **PC Controlled Secure Load Switching Using Microcontroller** is the bonafide work carried out by **ANKITA BANERJEE (11701617073)**, **ABHISHEK KUMAR MISHRA (11701617077)**, **DIPANKAR BISWAS (11701617063)**, **SAIKAT MONDAL (11701617043)**, the students of B.Tech in the Department of Electrical Engineering, RCC Institute of Information Technology (RCCIIT), Canal South Road, Beliaghata, Kolkata-700015, affiliated to Maulana Abul Kalam Azad University of Technology (MAKAUT), West Bengal, India, during the academic year 2020-21, in partial fulfillment of the requirements for the degree of Bachelor of Technology in Electrical Engineering and that this project has not submitted previously for the award of any other degree, diploma and fellowship.

(Budhacharya Biswas)  
Assistant Professor  
Department of Electrical Engineering  
RCC Institute of Information Technology

Countersigned by

HoD, Dept. of EE  
RCC Institute of Information Technology  
Kolkata-700015

(Dr. Debasish Mondal)  
HOD, Electrical Engineering Dept  
RCC Institute of Information Technology

## **ACKNOWLEDGEMENT**

It is our great fortune that we have got opportunity to carry out this project work under the supervision of **Mr. Budhaditya Biswas** in the Department of Electrical Engineering, RCC Institute of Information Technology (RCCIIT), Canal South Road, Beliaghata, Kolkata-700015, affiliated to Maulana Abul Kalam Azad University of Technology (**MAKAUT**), West Bengal, India. We express our sincere thanks and deepest sense of gratitude to our guide for his constant support, unparalleled guidance and limitless encouragement.

We would also like to convey our gratitude to all the faculty members and staffs of the Department of Electrical Engineering, RCCIIT for their whole hearted cooperation to make this work turn into reality.

We are very thankful to our Department and to the authority of RCCIIT for providing all kinds of infrastructural facility towards the research work.

Thanks to the fellow members of our group for working as a team.

**ANKITA BANERJEE (11701617073)**  
**ABHISHEK KUMAR MISHRA (11701617077)**  
**DIPANKAR BISWAS (11701617063)**  
**SAIKAT MONDAL (11701617043)**

To

The Head of the Department  
Department of Electrical Engineering  
RCC Institute of Information Technology  
Canal South Rd. Beliaghata, Kolkata-700015

Respected Sir,

In accordance with the requirements of the degree of Bachelor of Technology in the Department of Electrical Engineering, RCC Institute of Information Technology, we present the following thesis entitled “**PC CONTROLLED SECURE LOAD SWITCHING USING MICROCONTROLLER**”. This work was performed under the valuable guidance of Mr. Budhaditya Biswas, Assistant Professor in the Dept. of Electrical Engineering.

We declare that the thesis submitted is our own, expected as acknowledge in the test and reference and has not been previously submitted for a degree in any other Institution.

Yours Sincerely,

**ANKITA BANERJEE (11701617073)**

*Ankita Banerjee*

**ABHISHEK KUMAR MISHRA (11701617077)**

*Abhishek Mishra*

**DIPANKAR BISWAS (11701617063)**

*Dipankar Biswas.*

**SAIKAT MONDAL (11701617043)**

*Saikat Mondal*

# Contents

<b>Topic</b>	<b>Page No.</b>
List of figures	i
List of tables	ii
Abbreviations and acronyms	iii
Abstract	iv
<b>Chapter 1 (Introduction)</b>	
Introduction	2
1.1 Home Automation	2
1.2 Overview & Benefits	3
1.3 Organization of Thesis	4
<b>Chapter 2 (Literature Review)</b>	6
<b>Chapter 3 (Theory)</b>	
3.1 Basic of serial communication	9
3.1.1 Baud Rate	9
3.1.2 Framing the data	9
3.1.3 Data chunk	9
3.1.4 Synchronization bits	10
3.1.5 Parity Bits	10
3.1.6 9600 baud rate communication using AT89c51	10
3.2 Serial Communication using RS-232	11
3.2.1 What is RS-232	11
3.2.2 How RS-232 Works	11
3.2.3 Asynchronous Serial communication using RS-232	12

3.3	Overview of the projects	13
3.4	Circuit Diagram	14
<b>Chapter 4 (Hardware modeling)</b>		
4.1	Main Features of the Prototype	16
4.2	Photographs of the prototype	16
4.3	Step by step operation of the prototype	17
4.4	Components Required	18
4.5	Hardware Interfacing	19
4.5.1	16×2 LCD Module interfacing	19
4.5.2	LCD AT Commands	20
4.5.3	LCD Reset Subroutine in AT89c51	20
4.5.4	LCD Initialization Subroutine in AT89c51	21
4.5.5	LCD Command Subroutine in AT89c51	21
4.5.6	LCD Display Subroutine in AT89c51	22
4.5.7	Relay Driver Interfacing with $\mu$ C	22
<b>Chapter 5 (Logic &amp; Operation)</b>		
5.1	Introduction	24
5.2	Flow chart	24
5.3	Principle & operations	25
5.4	Advantages of the BT Load switching	25
5.5	Disadvantages	26
5.6	Cost estimation of the project	26
5.7	Photographs of the prototype	27
<b>Chapter 6 (Conclusion &amp; Future scope)</b>		
6.1	Conclusion	30
6.2	Results	30

6.3	Future works	30
<b>Chapter 7 (Reference)</b>		32
<b>Appendix A (Hardware Description)</b>		34 – 43
<b>Appendix B (Software Coding)</b>		45 – 47
<b>Appendix C (Datasheets)</b>		48



# List of Figures

<b>Sl. No.</b>	<b>Figure</b>	<b>Page No.</b>
1	Concept of home automation	2
2	A serial frame	9
3	9600 baud rate bit pattern	10
4	RS-232 Cable	11
5	RS-232 Protocol	12
6	Overview of the complete project	13
7	Complete circuit diagram of the project	14
8	Main controller and relay board	16
9	4 bit mode LCD interfacing	19
10	8 bit mode LCD interfacing	19
11	ULN2003A interfacing with microcontroller	22
12	Main controller board	27
13	The Relay board	27
14	Different messages on the LCD	28
15	Complete setup of the project	28
16	Transformer less SMPS 5 V power supply	34
17	AT89c51 pin diagram	35
18	16 x 2 LCD Module	37
19	LCD Pin diagram	37
20	ULN 2003a internal block diagram	38
21	Resistor	38
22	Colour code for resistance	39
23	6 Volt cube relay	40
24	Types of capacitors	41
25	Crystal oscillator	42
26	Pizzo Buzzer	42
27	A blank glass epoxy PCB board	43

# List of Tables

<b>Sl. No.</b>	<b>Table</b>	<b>Page No.</b>
1	Pinout of RS232	11
2	Component Listing	18
3	LCD AT Command	20
4	Cost estimation of the project	26
5	Pin description of AT89c51 $\mu$ C	36

# ABBREVIATIONS AND ACRONYMS

***HVAC*** – Heating Ventilation and Air *Conditioning*

***IC*** - Integrated Circuit

***PCB*** – Printed Circuit Board

***μC*** – Micro Controller

***BJT*** - Bi-polar Junction Transistor

***SPDT*** - Single Pole Double Throw

***NO*** - Normally Open

***NC*** - Normally Closed

***COM*** – Common

***LCD*** – Liquid Crystal Display

***LED*** - Light Emitting Diode

***POT*** – Potentiometer

***AT*** – Attention Command

***SMPS*** – Switch Mode Power Supply

***RF*** – *Radio Frequency*

***ISM*** – Industrial, scientific and medical

***USB*** – Universal serial bus

***SPI*** – Serial Peripheral Interface

***I<sup>2</sup>C*** – Inter-Integrated Circuit

***TXD*** – Transmitter

***RXD*** – Receiver

***RTS*** – Request to send

***CTS*** – Clear to send

***GND*** – Ground

# **ABSTRACT**

Traditionally electrical appliances in a home are controlled via switches that regulate the electricity to these devices. As the world gets more and more technologically advanced, new technology coming in deeper and deeper into our personal lives even at home. Home automation is becoming more and more popular around the world and is becoming a common practice. The process of home automation works by making everything in the house automatically controlled using technology to control and do the jobs that we would normally do manually. Home automation takes care of a lot of different activities in the house.

The remote load switching is done based on the RS232 serial communication and using the help of AT89c51 microcontroller. When a command is sent through the serial port of the PC to the microcontroller a particular load is switched ON. If the same command is sent again the same load will be switched OFF. The whole thing is protected by password to improve the security of the system. Basically, when a key is pressed from the keyboard of the PC an ASCII code is generated and the same ASCII code will transfer to the controller through the serial port of the PC. If the controller receives a particular ASCII code, then it actuates the relay driver. The relay driver drives the relay to switch on/off the domestic electrical loads. The controller also provides some audio feedback to assure the user that the load switching has been done properly.

The load status is shown in a 16x2 LCD module which is mounted to the controller board. The status is also shown in the computer screen through a serial communication window.

# **CHAPTER 1**

## **(Introduction)**

# INTRODUCTION

The aim of the proposed system is to develop a cost-effective solution that will provide controlling of home appliances remotely and enable home security against intrusion in the absence of homeowner. The system provides availability due to development of a low-cost system. The home appliances control system with an affordable cost was thought to be built that should be RS232 providing remote access to the appliances and allowing home security. Though devices connected as home and office appliances consume electrical power. These devices should be controlled as well as turn on/off if required. Most of the times it was done manually. Now it is a necessity to control devices more effectively and efficiently at anytime from anywhere.

In this system, we are going to develop a PC controlled based home/office appliance. This system is designed for controlling arbitrary devices, it includes a PC (end user has to connect his/her PC to the system) which is connected to the system via RS-232 cable. the RS 232 cable is used for serial communication which acts as a bridge between the microcontroller and the load. Now, when a command is given to the microcontroller AT89c51 it immediately changes the state of the load. The commands that are being passed through the microcontroller are in the form of ASCII code. When a specific ASCII code is passed, the status of the load is changed and a feedback is given to the microcontroller regarding the status of the load that is being displayed on the LCD. Also, the whole system is password protected for security reasons. If the controller receives the correct password, then it actuates the relay driver. The relay driver drives the relay to switch on/off the domestic electrical loads. The device switching is achieved by Relays. Security preserved because these dedicated passwords owned and known by selected persons only. For instance, our system contains an alarm unit giving the user a remote on/off mechanism.

## 1.1 HOME AUTOMATION

**Home automation** is the residential extension of building automation. It is automation of the home, housework or household activity. Home automation may include centralized

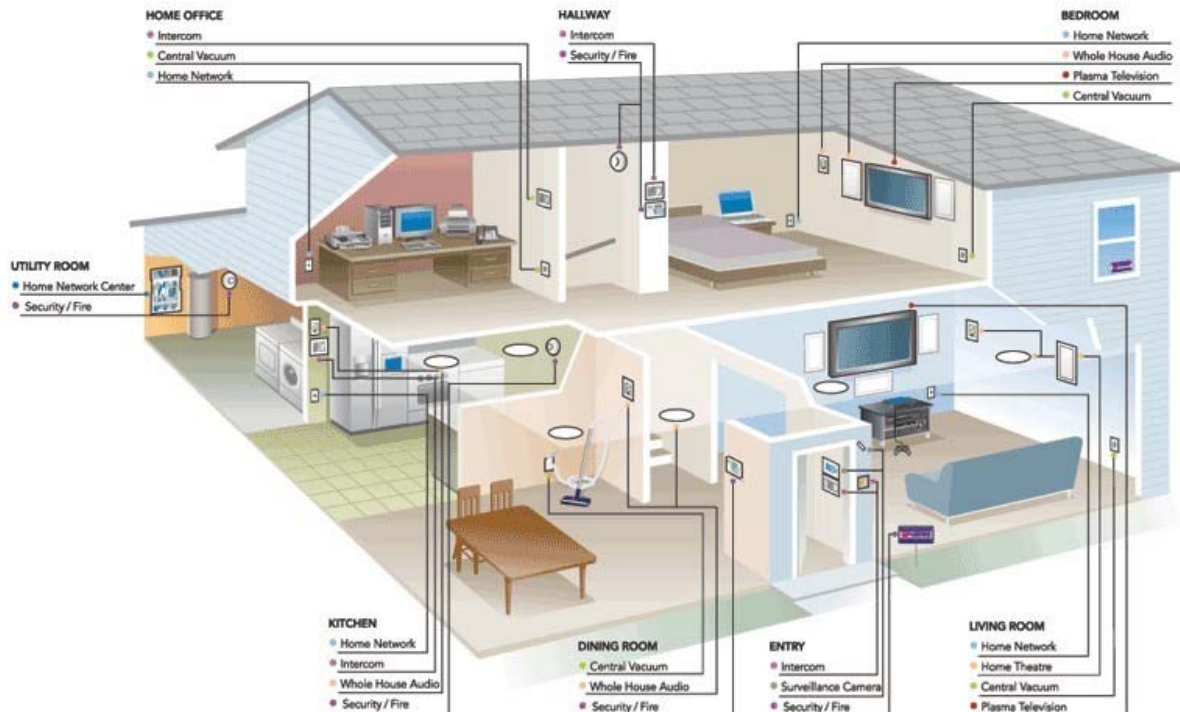

Figure 1: Concept of Home Automation

control of lighting, HVAC (heating, ventilation and air conditioning), appliances, security locks of gates and doors and other systems, to provide improved convenience, comfort, energy efficiency and security. Home automation for the elderly and disabled can provide increased quality of life for persons who might otherwise require caregivers or institutional care.

The popularity of home automation has been increasing greatly in recent years due to much higher affordability and simplicity through Smartphone and tablet connectivity. The concept of the "Internet of Things" has tied in closely with the popularization of home automation.

A home automation system integrates electrical devices in a house with each other. The techniques employed in home automation include those in building automation as well as the control of domestic activities, such as home entertainment systems, houseplant and yard watering, pet feeding, changing the ambiance "scenes" for different events (such as dinners or parties), lighting control system, and the use of domestic robots. Devices may be connected through a home network to allow control by a personal computer, and may allow remote access from the internet. Through the integration of information technologies with the home environment, systems and appliances can communicate in an integrated manner which results in convenience, energy efficiency, and safety benefits.

Automated "homes of the future" have been staple exhibits for World's Fairs and popular backgrounds in science fiction. However, problems with complexity, competition between vendors, multiple incompatible standards and the resulting expense have limited the penetration of home automation to homes of the wealthy, or ambitious hobbyists. Possibly the first "home computer" was an experimental home automation system in 1966.

## **1.2 Overview and benefits**

Home automation refers to the use of computer and information technology to control home appliances and features (such as windows or lighting). Systems can range from simple remote control of lighting through to complex computer/microcontroller-based networks with varying degrees of intelligence and automation. Home automation is adopted for reasons of ease, security and energy efficiency.

In modern construction in industrialized nations, most homes have been wired for electrical power, telephones, TV outlets (cable or antenna), and a doorbell. Many household tasks were automated by the development of specialized automated appliances. For instance, automatic washing machines were developed to reduce the manual labor of cleaning clothes, and water heaters reduced the labor necessary for bathing.

The use of gaseous or liquid fuels, and later the use of electricity enabled increased automation in heating, reducing the labor necessary to manually refuel heaters and stoves. Development of thermostats allowed more automated control of heating, and later cooling.

As the number of controllable devices in the home rises, interconnection and communication becomes a useful and desirable feature. For example, a furnace can send an alert message when it needs cleaning or a refrigerator when it needs service. If no one is supposed to be home and the alarm system is set, the home automation system could call the owner, or the neighbors, or an emergency number if an intruder is detected.

In simple installations, automation may be as straightforward as turning on the lights when a person enters the room. In advanced installations, rooms can sense not only the presence of a person inside but know who that person is and perhaps set appropriate lighting, temperature,

music levels or television channels, taking into account the day of the week, the time of day, and other factors.

Other automated tasks may include reduced setting of the heating or air conditioning when the house is unoccupied, and restoring the normal setting when an occupant is about to return. More sophisticated systems can maintain an inventory of products, recording their usage through bar codes, or an RFID tag, and prepare a shopping list or even automatically order replacements.

Home automation can also provide a remote interface to home appliances or the automation system itself, to provide control and monitoring on a Smartphone or web browser.

An example of remote monitoring in home automation could be triggered when a smoke detector detects a fire or smoke condition, causing all lights in the house to blink to alert any occupants of the house to the possible emergency. If the house is equipped with a home theater, a home automation system can shut down all audio and video components to avoid distractions, or make an audible announcement. The system could also call the home owner on their mobile phone to alert them, or call the fire department or alarm monitoring company.

### **1.3 Organisation of thesis**

The thesis is organised into five chapters including the chapter of introduction. Each chapter is different from the other and is described along with the necessary theory required to comprehend it.

**Chapter 2** deals with the literature reviews. From this chapter we can see before our project who else works on this topic and how our project is different and advance from those projects.

**Chapter 3** deals with the theory required to do the project. The basic of serial communication with microcontroller at 9600 baud rate and the communication with HC 05 are described here. The overview of the project and software simulation of the project is also listed in this chapter.

**Chapter 4** deals with the hardware modelling of the projects. The main features, photographs, step by step operation of the prototype, component listing and the hardware interfacing of the required components are described here.

**Chapter 5** describes the basic operation of the circuit. A flow chart is presented on the actions that would take in the controller beginning from the pairing of the android device with the Bluetooth module HC 05 to the switching on and off of loads. Advantages and disadvantages and cost estimation are listed in this chapter.

**Chapter 6** concludes the work performed so far. The possible limitations in proceeding research towards this work are discussed. The future work that can be done in improving the current scenario is mentioned. The future potential along the lines of this work is also discussed.

**Chapter 7** References are listed in this chapter

**Appendix A, B & C** Hardware description, software coding and datasheets are listed here.



# **CHAPTER 2**

**(Literature Review)**

The system proposed in [1] uses the methodology of serial communication with embedded system. A personal computer (PC) is used to send signal, with the microcontroller as the controlling circuit and relay as the switching circuit to control devices connected to it.

The aim of the system [2] was to control the electrical appliances through a personal computer (PC). For example, theatre lighting can be centrally controlled from the pc for better stage management.

The system proposed in [3] describes an architectural framework and a middleware supporting a component-based system and an integrated view on events-based communication comprising the real-world events and the events generated in the system.

In this paper [4], it presents an advanced universal remote controller (URC) with the total solution for home automation and security. All kinds of home appliances can be controlled with the URC, which can be also connected to a PC dealing with Internet as well.

The system proposed in [5] , is based on the dual tone multifrequency (DTMF) signals that could be sent through a loop of wire to switch on/off various appliances via a personal computer (PC).

In system [6] a microcontroller-based controller is designed to control a number of electrical equipment. To control and monitor connected equipment through the PC.

The personal computer is [7] used to control the electrical appliances which includes turning high power alternating current (AC) loads such as lights, fans, heaters etc ON or OFF. To successfully integrate the interface box with the machine (laptop), an interface device is used within the PC that can perform the necessary tasks. The interface box can be controlled by the computer by connecting to the USB port and developed a program in C-sharp (C#) programming language. The program will demonstrate the basic idea of how to control devices and monitor events.

The aim of this project [8] is to control the electrical appliances through a personal computer (PC). With this system, one can control the electrical appliances ON/OFF by just being seated at one place using a PC. This system is integrated with the electrical loads and also connected to the PC where centralized control takes place. It uses an RS-232 protocol from the microcontroller to communicate with the PC. This project can be further enhanced by implementing a GUI based control panel on the PC with appropriate embedded software. The intensity control can also be incorporated using power electronics devices.

This paper shows [9] how ATMEGA168 microcontroller can be used to remotely control security lighting via Short Message Service (SMS) from a Global System for Mobile Communication (GSM) phone anywhere outside the home. A Mobile phone is configured to transmit SMS signal to a home-based GSM modem. The GSM Modem then sends the received SMS to a ATMEGA168 microcontroller.

The main aim [10] of the automation system is to on/off the device at the specified time by using desktop, which can be placed even in other room. The on/off system can be programmed well in advance and there is no need to perform the operation at that particular time.

In this paper [11] we present a Home Automation system(HAS) using Intel Galileo that employs the integration of cloud networking, wireless communication, to provide the user with remote control of various lights, fans, and appliances within their home and storing the data in the cloud. The system will automatically change on the basis of sensors' data. This system is designed to be low cost and expandable allowing a variety of devices to be controlled

In this paper [12], we present the design and implementation of home automation system. The design has been described using VHDL and implemented in hardware using FPGA (Field Programmable Gate Array). This system uses GSM (Global System for Mobile) network to establish the communication between mobile and controller. The system is SMS (Short Messaging Service) based and uses wireless technology to improve the standards of living.

# **CHAPTER 3**

**(Theory)**

## 3.1 Basic of Serial Communication

The asynchronous serial protocol has a number of built-in rules - mechanisms that help ensure robust and error-free data transfers. These mechanisms, which we get for eschewing the external clock signal, are:

- Data bits,
- Synchronization bits,
- Parity bits,
- and Baud rate.

Through the variety of these signaling mechanisms, you'll find that there's no one way to send data serially. The protocol is highly configurable. The critical part is making sure that **both devices on a serial bus are configured to use the exact same protocols.**

### 3.1.1 Baud Rate

The baud rate specifies **how fast** data is sent over a serial line. It's usually expressed in units of bits-per-second (bps). If you invert the baud rate, you can find out just how long it takes to transmit a single bit. This value determines how long the transmitter holds a serial line high/low or at what period the receiving device samples its line.

Baud rates can be just about any value within reason. The only requirement is that both devices operate at the same rate. One of the more common baud rates, especially for simple stuff where speed isn't critical, is **9600 bps**. Other "standard" baud are 1200, 2400, 4800, 19200, 38400, 57600, and 115200.

The higher a baud rate goes, the faster data is sent/received, but there are limits to how fast data can be transferred. You usually won't see speeds exceeding 115200 - that's fast for most microcontrollers. Get too high, and you'll begin to see errors on the receiving end, as clocks and sampling periods just can't keep up.

### 3.1.2 Framing the data

Each block (usually a byte) of data transmitted is actually sent in a *packet* or *frame* of bits. Frames are created by appending synchronization and parity bits to our data.



Figure 2: A serial frame.

Some symbols in the frame have configurable bit sizes. Let's get into the details of each of these frame pieces.

### 3.1.3 Data chunk

The real meat of every serial packet is the data it carries. We ambiguously call this block of data a *chunk*, because its size isn't specifically stated. The amount of data in each packet can be set to anything from 5 to 9 bits. Certainly, the standard data size is your basic 8-bit byte, but other sizes have their uses. A 7-bit data chunk can be more efficient than 8, especially if you're just transferring 7-bit ASCII characters.

After agreeing on a character-length, both serial devices also have to agree on the **endianness** of their data. Is data sent most-significant bit (msb) to least, or vice-versa? If it's not otherwise stated, you can usually assume that data is transferred **least-significant bit (lsb) first**.

### 3.1.4 Synchronization bits

The synchronization bits are two or three special bits transferred with each chunk of data. They are the **start bit** and the **stop bit(s)**. True to their name, these bits mark the beginning and end of a packet. There's always only one start bit, but the number of stop bits is configurable to either one or two (though it's commonly left at one).

The start bit is always indicated by an idle data line going from 1 to 0, while the stop bit(s) will transition back to the idle state by holding the line at 1.

### 3.1.5 Parity bits

Parity is a form of very simple, low-level error checking. It comes in two flavors: odd or even. To produce the parity bit, all 5-9 bits of the data byte are added up, and the evenness of the sum decides whether the bit is set or not. For example, assuming parity is set to even and was being added to a data byte like `0b01011101`, which has an odd number of 1's (5), the parity bit would be set to 1. Conversely, if the parity mode was set to odd, the parity bit would be 0.

Parity is *optional*, and not very widely used. It can be helpful for transmitting across noisy mediums, but it'll also slow down your data transfer a bit and requires both sender and receiver to implement error-handling (usually, received data that fails must be re-sent).

### 3.1.6 9600 baud rate communication using AT89c51

9600 8N1 - 9600 baud, 8 data bits, no parity, and 1 stop bit - is one of the more commonly used serial protocols. So, what would a packet or two of 9600 8N1 data look like? Let's have an example

A device transmitting the ASCII characters 'O' and 'K' would have to create two packets of data. The ASCII value of *O* (that's uppercase) is 79, which breaks down into an 8-bit binary value of `01001111`, while *K*'s binary value is `01001011`. All that's left is appending sync bits.

It isn't specifically stated, but it's assumed that data is transferred least-significant bit first. Notice how each of the two bytes is sent as it reads from right-to-left.



Figure 3: 9600 baud rate bit pattern

Since we're transferring at 9600 bps, the time spent holding each of those bits high or low is  $1/(9600 \text{ bps})$  or  $104 \mu\text{s}$  per bit.

For every byte of data transmitted, there are actually 10 bits being sent: a start bit, 8 data bits, and a stop bit. So, at 9600 bps, we're actually sending 9600 bits per second or 960 (9600/10) bytes per second.

Now that you know how to construct serial packets, we can move on to the hardware section. There we'll see how those 1's and 0's and the baud rate are implemented at a signal level.

## 3.2 Serial Communication using RS-232

RS232 is one of the standard protocols in telecommunication which is used for serial communication of data. It is the process of connecting signals between data terminal equipment (DTE) for example, file server, routers and application servers, such as a modem.



Figure 4: RS-232 Cable

The standard interprets electrical features and important timings of signal and the physical size and points of the connectors. The RS232 standard has been mostly utilized in computer ports. It involves two types of communication, serial and parallel.

### 3.2.1 What is RS-232

RS232C “Recommended Standard 232C” is the recent version of Standard 25 pin whereas, *RS232D* which is of 22 pins. In new PC’s male D-type which is of 9 pins.

### 3.2.2 How RS-232 Works

RS232 works on the two-way communication that exchanges data to one another. There are two devices connected to each other, **(DTE) Data Transmission Equipment** & **(DCE) Data Communication Equipment** which has the pins like **TXD, RXD, and RTS & CTS**. Now, from **DTE** source, the **RTS** generates the *request to send* the data. Then from the other side **DCE**, the **CTS**, clears the path for receiving the data. After clearing a path, it will give a signal to **RTS** of the **DTE** source to send the signal. Then the bits are transmitted from **DTE** to **DCE**. Now again from **DCE** source, the request can be generated by **RTS** and **CTS** of **DTE** sources clears the path for receiving the data and gives a signal to send the data. This is the whole process through which data transmission takes place.

Table 1: Pinout of RS232

X\H\$	XVERWQ MXIV\$
V\H\$	VIGIMZIV\$
VXW\$	VIUYIWX\$S \$WIRH\$
GXW\$	GPIEV\$S \$WIRH\$
KRH\$	KVSYRH\$

### 3.2.3 Asynchronous Serial communication using RS-232

RS232 strictly follows asynchronous communication protocol i.e., there is no clock signal to synchronize the sender and receiver. Hence, it needs start and stop bits to inform the receiver when to check for data. There is a delay of certain time between the transmissions of each bit. This delay is an inactive state means the signal is set to -12 volts or logic “1” as mentioned earlier that logic 1 is -12 volts and logic 0 is 12 volts in RS232.

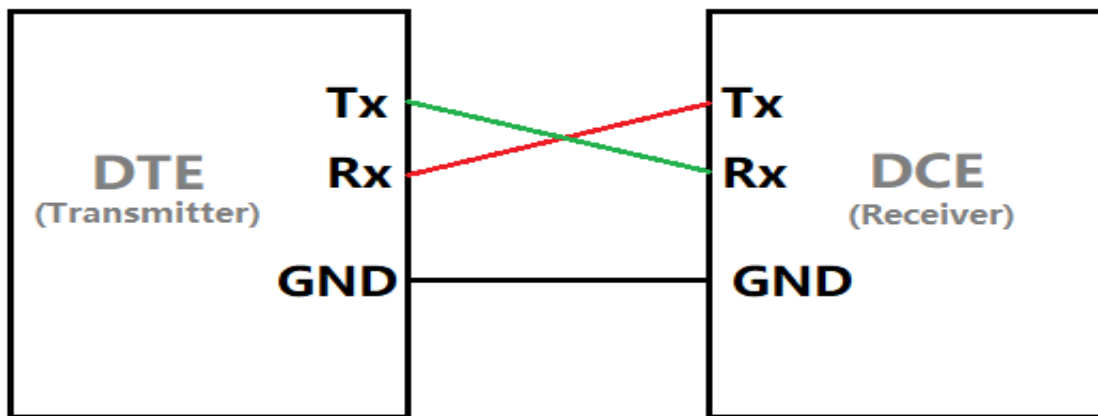

Figure 5: RS-232 Protocol

First, the transmitter i.e., the DTE sends a Start bit to the receiver i.e., the DCE to inform it that data transmission starts from next bit. We always keep Start bit as logic 0 or +12 volts and the next 5 to 9 characters are the data bits.

If parity bit is used, the maximum bits of 8 can be transmitted and if parity bit is not used then 9 data bits can be transmitted. After successfully sending the data the transmitter sends the stop bits which can be 1 bit, 2 bits or 5 bits long.

Going by the fact that RS232 is a complete standard, many manufacturers does not follow the standards. Some of them abide by the complete identifications while some only partly follow the specifications

This is because this variation in implementation of the RS232 standard is that not all devices and applications require the full specifications and functionality of the RS232 Protocol. For instance, a serial model which is using a RS2323 may require more control lines than a serial mouse using the serial port.

The process of transmitting and receiving which uses different identifications altogether is backed up by another process called the Handshaking. Handshaking is a process that actively places the parameters of a communication between the transmitter and receiver before communication beginning. The requirement of handshaking is dependent on the speed of the transmitter at which it sends the data to the receiver and the speed at which the receiver receives it. In case of asynchronous data transmission system, there can also be no requirement of handshaking.



### 3.3 Overview of the project

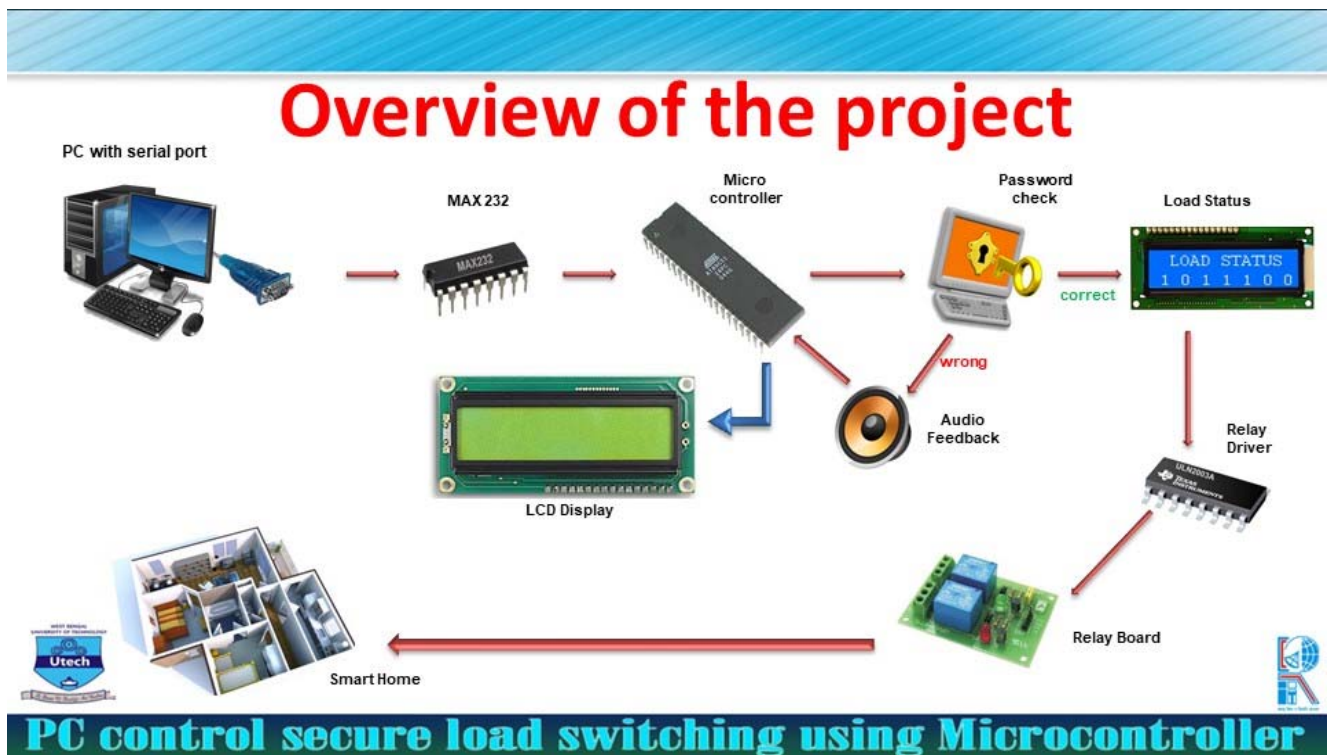

Figure 6: Overview of the complete project

In our project we interface RS-232 cable to the microcontroller AT89c51. The interfacing is done through the serial communication using 9600 baud-rate. RS232 voltage levels are not compatible with TTL logic. Therefore, while connecting an RS232 to microcontroller system, a voltage converter is required. This converter converts the microcontroller output level to the RS232 voltage levels, and vice versa. IC MAX232, also known as line driver, is very commonly used for this purpose. Now, when a command is given to the microcontroller AT89c51 it immediately changes the state of the load. The commands that are being passed through the microcontroller are in the form of ASCII code. When a specific ASCII code is passed, the status of the load is changed and a feedback is given to the microcontroller regarding the status of the load that is being displayed on the LCD. The whole setup is password protected. Without receiving the correct password, PC is not able to control the relays. The complete layout of the project is shown in the figure 6. Here we implemented audio feedback section. The password checking, relay switching are taking the attention of the user using the particular audio feedback. The relay board has a relay driver (ULN 2003A). The relays are controlled by the microcontroller and they are able to handle 230 V ac with 7 A load current. A  $16 \times 2$  LCD is displaying the status of the circuit and the load status all the time.

### 3.4 Circuit Diagram

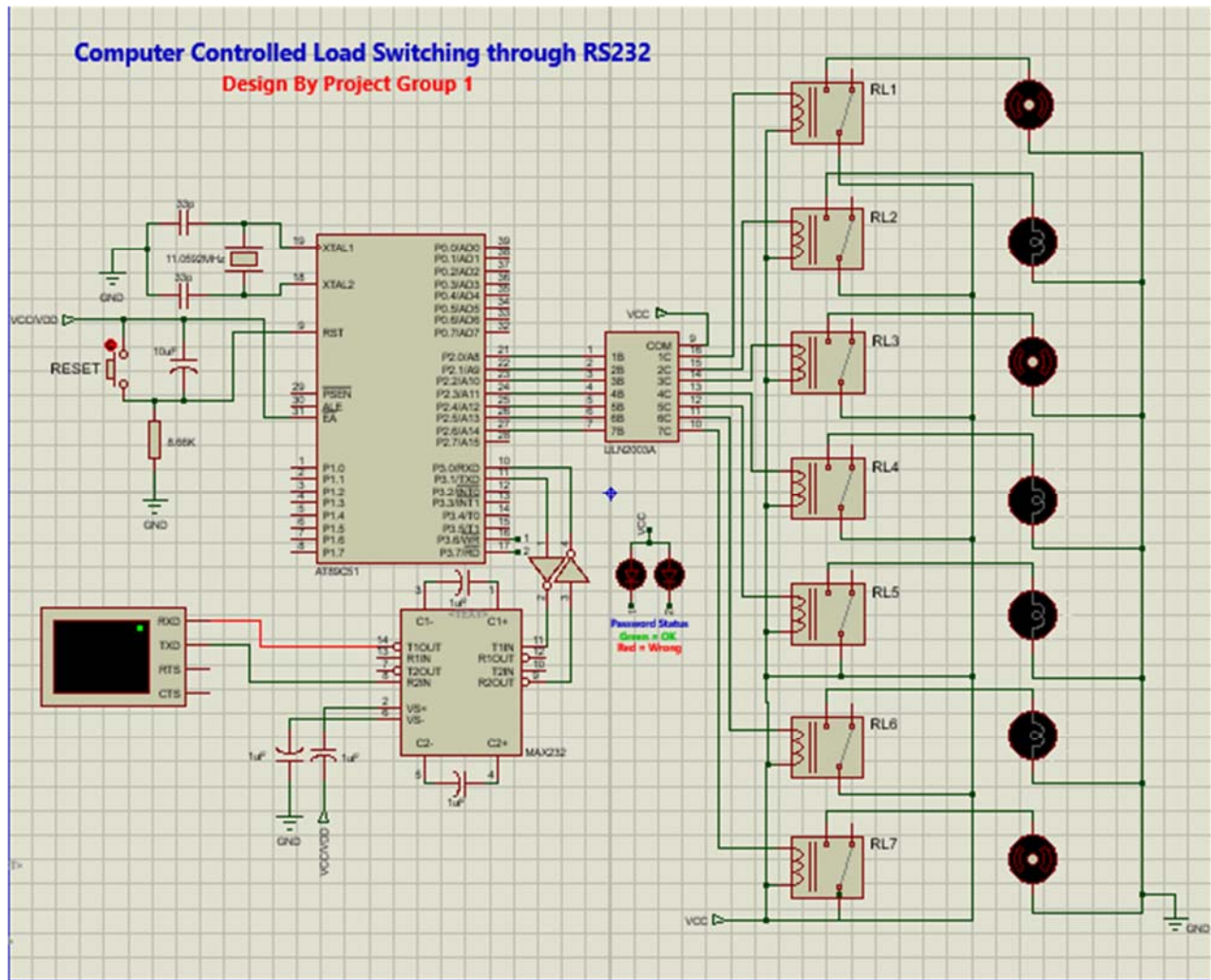

Figure 7: Complete circuit Diagram of the Project

The complete circuit is first simulated in the PROTEUS software, the screenshot of the PROTEUS window is shown in figure 7. The circuit is running well in this software. The software simulation includes microcontroller (AT89c51), serial monitor, level converter (TTL to RS232 level shifter and vice versa), relay driver section (low power to high power converter) and the relay section. Here we incorporate 7 loads which can be controlled individually or simultaneously as per user choice. The indicator section consists of two LEDs (for indicating the password status of the circuit). If the password is ok then the LED will be green and if the password is wrong then LED will be red.

The microcontroller uses 11.0592 MHz crystal for generating exactly 9600 baud rate which is the main criterion for RS-232 serial communication.

# **CHAPTER 4**

## **(Hardware Modeling)**

## 4.1 Main features of the prototype

The features of the developed prototype are:

- Secure (password protected)
- LCD display (showing the condition of the load status and the status of the circuit)
- 7 independent load controls (250 volt, 7 amp max, ON/OFF control)
- Inbuilt relay driver
- Texted mode of control. Here the load status will be displayed in the remote device
- Buzzer indication during load switching
- On board password status LEDs
- 5 Volt operation (both control board and relay board)
- Centralized control

## 4.2 Photographs of the prototype

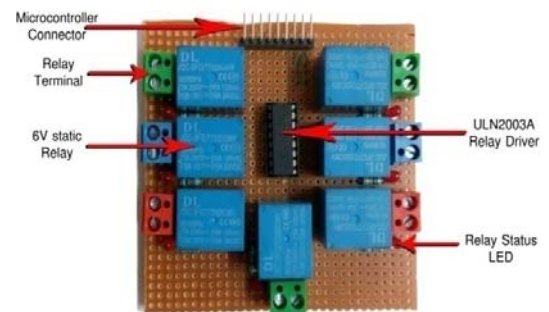
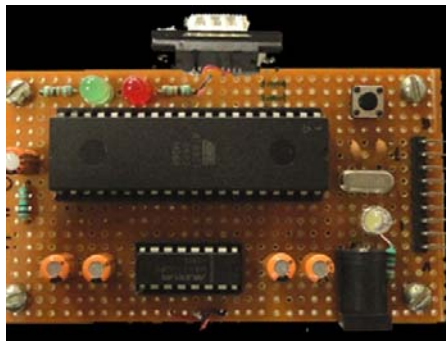
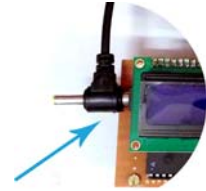

Figure 8: Main Controller and Relay board

### 4.3 Step by step operation of the prototype

1. Connect the DC adapter (5V, 1A) to the DC jack.



2. Power On the circuit
3. Open the software for establishing serial communication in the PC
4. select the proper COM port in the PC where the circuit is connected
5. After establishing the connection, a welcome message will be displayed in the screen.
6. It will ask for the password in “tera term”

7. Give the correct password (9537)



8. If the password is correct the blue LED will glow ON.
9. Load status will be displayed on the LCD as well as in the PC screen
10. 1-7 for controlling the 7 independent loads, they are toggles if you press 1 to 7. 0 for all off simultaneously. 9 for all on simultaneously. 8 for returning the password mode.



## 4.4 Components required

Table 2: Component listing

Sl. No.	Components	Quantity
1	AT89c51 Microcontroller	1
2	MAX 232	1
3	RS-232 Cable	1
4	33 pf Capacitor	2
5	0.1 $\mu$ F Capacitor	2
6	10 $\mu$ F Capacitor	2
7	1 $\mu$ F, 16V Capacitor	4
8	330 $\Omega$ resistance	9
9	10 K POT	1
10	16x2 LCD Display	1
11	ULN 2003A IC (Relay Driver)	1
12	5 volt static Relay	7
13	Male pin header	2
14	Female pin header	1
15	3 mm LED (Red/Green)	9
16	General blank PCB	1
17	11.0592 MHz Crystal	1
18	Jumper wire	9
19	Piezo Buzzer	1
20	16 pin IC base	1
21	40 pin IC base	1
22	Single stand wire	3m
23	Wire nipper	1
24	Wire striper	1
25	Soldering Iron	1
26	Soldering material	1
27	De-soldering pump	1

## 4.5 Hardware interfacing

### 4.5.1 16 × 2 LCD Module interfacing

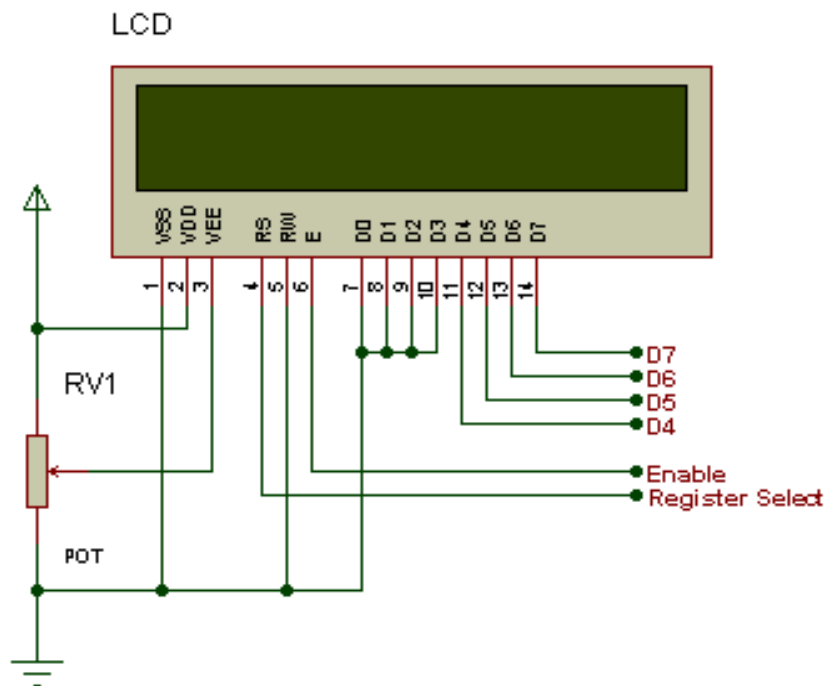

### 4 bit mode

Figure 9: 4 bit mode LCD Interfacing

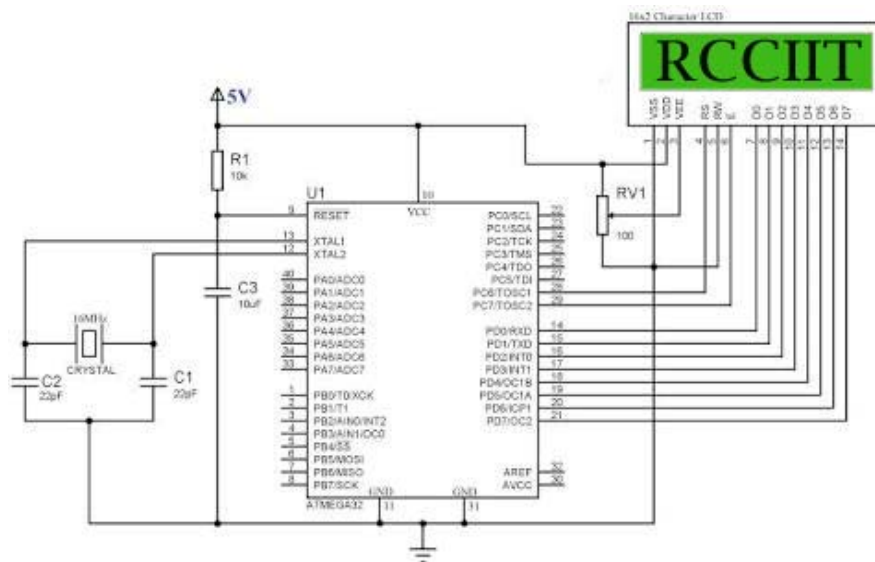

### 8 bit mode

Figure 10: 8 bit mode LCD Interfacing

## 4.5.2 LCD AT Commands

### LCD Command Codes

Code (Hex)	Command to LCD Instruction Register
1	Clear display screen
2	Return home
4	Decrement cursor (shift cursor to left)
6	Increment cursor (shift cursor to right)
5	Shift display right
7	Shift display left
8	Display off, cursor off
A	Display off, cursor on
C	Display on, cursor off
E	Display on, cursor blinking
F	Display on, cursor blinking
10	Shift cursor position to left
14	Shift cursor position to right
18	Shift the entire display to the left
1C	Shift the entire display to the right
80	Force cursor to beginning to 1st line
C0	Force cursor to beginning to 2nd line
38	2 lines and 5x7 matrix

Table 3: LCD Attention (AT) Command

## 4.5.3 LCD Reset subroutine in AT89c51

```
lcd_reset:                ;LCD reset sequence
    mov lcd_port, #0FFH
    mov delay, #20        ;20mS delay
    acall delaysms
    mov lcd_port, #83H    ;Data = 30H, EN = 1, First Init
    mov lcd_port, #03H    ;Data = 30H, EN = 0
    mov delay, #10       ;Delay 10mS
    acall delaysms
    mov lcd_port, #83H    ;Second Init, Data = 30H, EN = 1
    mov lcd_port, #03H    ;Data = 30H, EN = 0
    mov delay, #1        ;Delay 5mS
    acall delaysms
    mov lcd_port, #83H    ;Third Init
    mov lcd_port, #03H
    mov delay, #1        ;Delay 5mS
```



```

    acall delayms
    mov lcd_port, #82H    ;Select Data width (20H for 4bit)
    mov lcd_port, #02H    ;Data = 20H, EN = 0
    mov delay,#1         ;Delay 5mS
    acall delayms
ret

```

#### 4.5.4 LCD Initialization subroutine in AT89c51 (4 bit mode)

```

lcd_init:
    mov a,#28H           ;4-bit, 2 line, 5x7 dots
    acall CMND
    mov a,#0CH           ;LCD_DATAalay ON cursor OFF
    acall CMND
    mov a,#06H           ;Set entry mode (Auto increment)
    acall CMND
    mov a,#80H           ;Bring cursor to line 1
    acall CMND
ret

```

#### 4.5.5 LCD Command subroutine in AT89c51 (4 bit mode)

```

CMND:           ;LCD command Routine
    mov temp,a        ;Save a copy of command to temp
    swap a            ;Swap to use higher nibble
    anl a,#0FH        ;Mask the first four bits
    add a,#80H        ;Enable = 1, RS = 0, RW = 0
    mov lcd_port,a    ;Move it to lcd port
    mov delay,#3      ;5mS delay
    acall delayms
    CLR EN

    mov a,temp        ;Reload the command from temp
    anl a,#0FH        ;Mask first four bits
    add a,#80H        ;Enable = 1
    mov lcd_port,a    ;Move to port
    mov delay,#3      ;5mS delay
    acall delayms
    CLR EN
ret

```

#### 4.5.6 LCD Display subroutine in AT89c51 (4 bit mode)

```

DISP:                                ;LCD data Routine
    mov temp,a                        ;Keep copy of data in temp
    swap a                            ;We need higher nibble
    anl a,#0FH                        ;Mask first four bits
    add a,#0A0H                       ;Enable = 1, RS = 1, RW = 0
    mov lcd_port,a                    ;Move to lcd port
    mov delay,#3                      ;5mS delay
    acall delayms
    clr en                             ;Enable = 0

    mov a,temp                        ;Reload the data from temp
    anl a,#0FH                        ;we need lower nibble now
    add a,#0A0H                       ;Enable = 1, RS = 1, RW = 0
    mov lcd_port,a                    ;Move to lcd port
    mov delay,#3                      ;5mS delay
    acall delayms
    clr en                             ;Enable = 0

ret

```

#### 4.5.7 Relay Driver interfacing with microcontroller

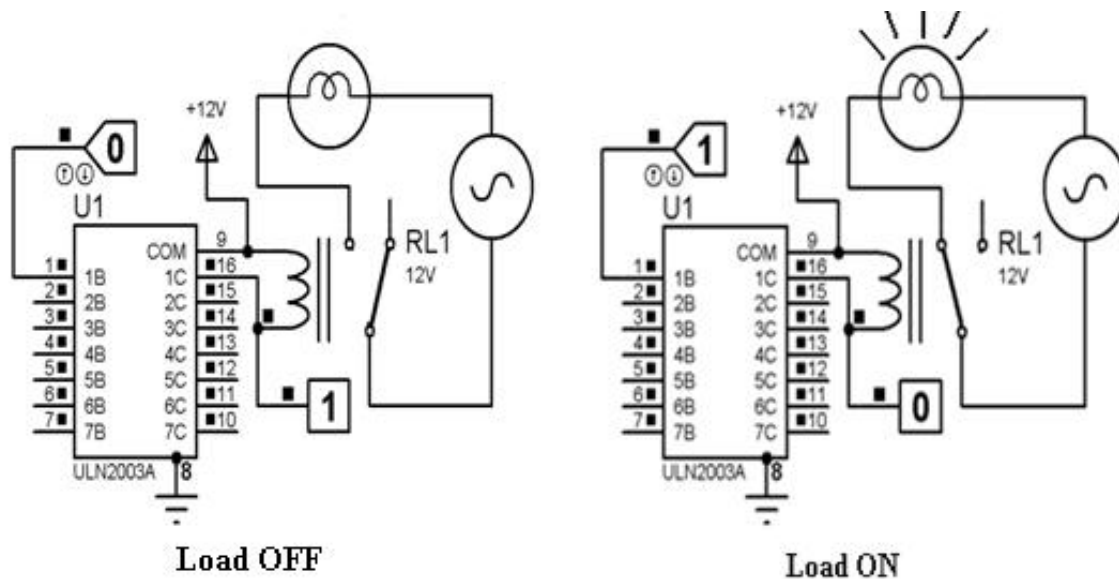

Figure 11: ULN2003A interfacing with microcontroller

The ULN2003A is an active high relay driver. 7 relays are controlled by this relay driver. Pins 1-7 are for controlling the relay which are connected to pins 10-16. For a '0' from the microcontroller, the corresponding relay is turned off, and for a '1' from the microcontroller, the relay is turned on.

# **CHAPTER 5**

## **(Logic & Operation)**

## 5.1 INTRODUCTION

After assembling the system, what remains is to observe its operation and efficiency of the system. The total system is divided in several sub systems, like

- RS 232 section
- Microcontroller section
- LCD section
- Audio feedback section
- Relay section

The operation of the whole circuit is depending on every sections performance.

## 5.2 Flow Chart

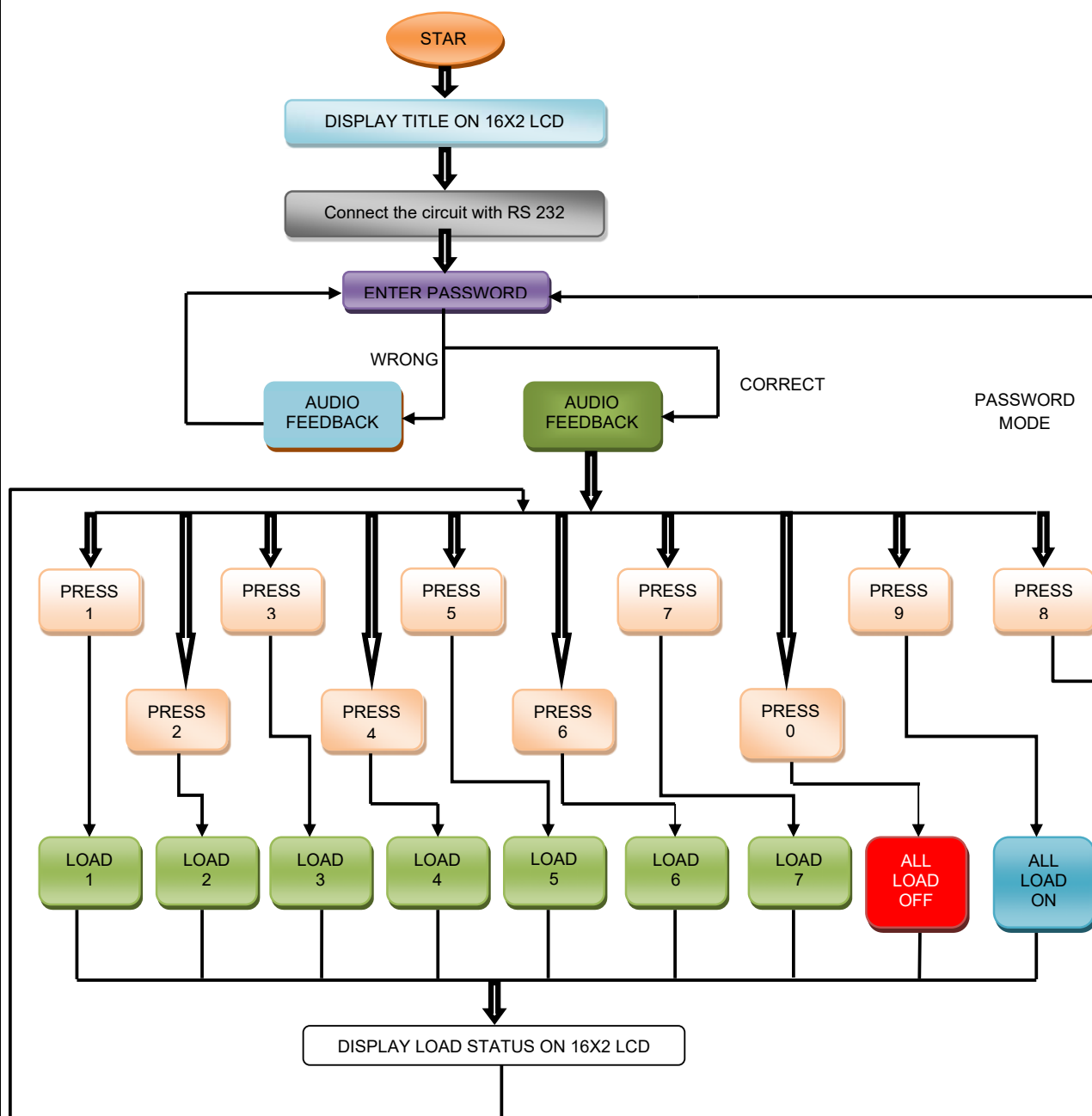

### 5.3 Principle & Operations

The RS232 standard uses the **serial communication** technique, which involves splitting the frequency band of 2.402-2.480 GHz into 79 channels (called *hops*) each 1MHz wide, then transmitting the signal using a sequence of channels known to both the sending and receiving stations. Thus, by switching channels as often as 1600 times a second, the Bluetooth standard can avoid interference with other radio signals.

First we connect the circuit device with the PC through RS 232 serial port. This signal is transmitted to the microcontroller through serial communication at 9600 baud rate. The microcontroller reads 5V but the HC 05 module sends signal in 3.3 volt. Here the MAX 232 level converter comes into play. It converts the 3.3 V to 5V, so that the signal is readable by the microcontroller. Microcontroller process the data. If the controller receives the correct password then it actuates the relay driver. If we input a wrong password, an audio feedback will be received. If we input the correct password, the load status would be showed in the LCD screen. Initially since all loads are off, the load status would be "0000". Here "0" stands for load OFF and "1" stands for load ON. The loads can be controlled by the Bluetooth device. The relay driver drives the relay to switch on/off the domestic electrical loads. The microcontroller output is 15mA. Relay reads 50mA. So the relay driver converts this 15mA to 50mA. This relay driver, as the name implies, actually drives the relay. The controller also provides some feedback to ensure that the load switching has been done properly. The loads are connected to the relays. Thus the loads can be controlled.

This was the password mode. In the open mode, there would be slight changes. There is a switch available in the relay board. By pressing the switch, we can convert the system from password mode to the non password or open mode and vice versa. In non password mode, only change is that we will not have to provide any passwords. The Bluetooth device will be directly connected. Other things remain same.

### 5.4 Advantages of the PC load switching

**A. Maintenance:** It is an economical system that requires very less maintenance as compared to conventional system as it has no complicated circuits and delicate mechanisms. This saves the additional maintenance cost.

**B. Cost :** The main advantage of this project is it has very low cost than the conventional one available in markets. For example, some commercial controllers use microcontrollers which alone costs around Rs.900. Some controllers even have a price range of Rs.2000-Rs. 4000. But for our system, the components used are less in number and easily available. Hence losses will be less leading to a better efficiency.

**C. Construction:** The construction of a BT based load switching system is very simple as it requires only a few components. The circuit involved is also relatively simpler. The space and power requirement to operate this system is very less.

**D. Skill Required:** Since the system we implement is simpler than the ones conventionally available, it can be easily made at home. The controller can also be easily operated by anyone.

## 5.5 Disadvantages

- The actual status of the load is unknown.
- No backup action will take for any false switching by controller itself.

## 5.6 Cost estimation of the project

Table 4: Costing of the projects

Sl. No.	Components	Quantity	Cost(Rs)
1	MAX 232	1	20
2	AT89c51 Microcontroller	1	45
3	33 pf Capacitor	2	2
4	0.1 $\mu$ F Capacitor	2	2
5	10 $\mu$ F Capacitor	2	4
6	1 $\mu$ F, 16V Capacitor	4	8
7	330 $\Omega$ resistance	9	9
8	10 K POT	1	10
9	16x2 LCD Display	1	130
10	ULN 2003A IC (Relay Driver)	1	20
11	5 volt static Relay	7	140
12	Male pin header	2	20
13	Female pin header	1	20
14	3 mm LED (Red/Green)	9	10
15	General blank PCB	1	30
16	Wire nipper	1	-
17	11.0592 MHz Crystal	1	10
18	Jumper wire	9	30
19	Piezo Buzzer	1	10
20	16 pin IC base	1	5
21	40 pin IC base	1	5
22	Single strand wire	3m	30
23	Wire striper	1	-
24	Soldering Iron	1	-
25	Soldering material	1	-
26	De-soldering pump	1	-
27	RS 232 cable and DB9 connector	1	130
	Total		890

5.7 Photographs of the prototype

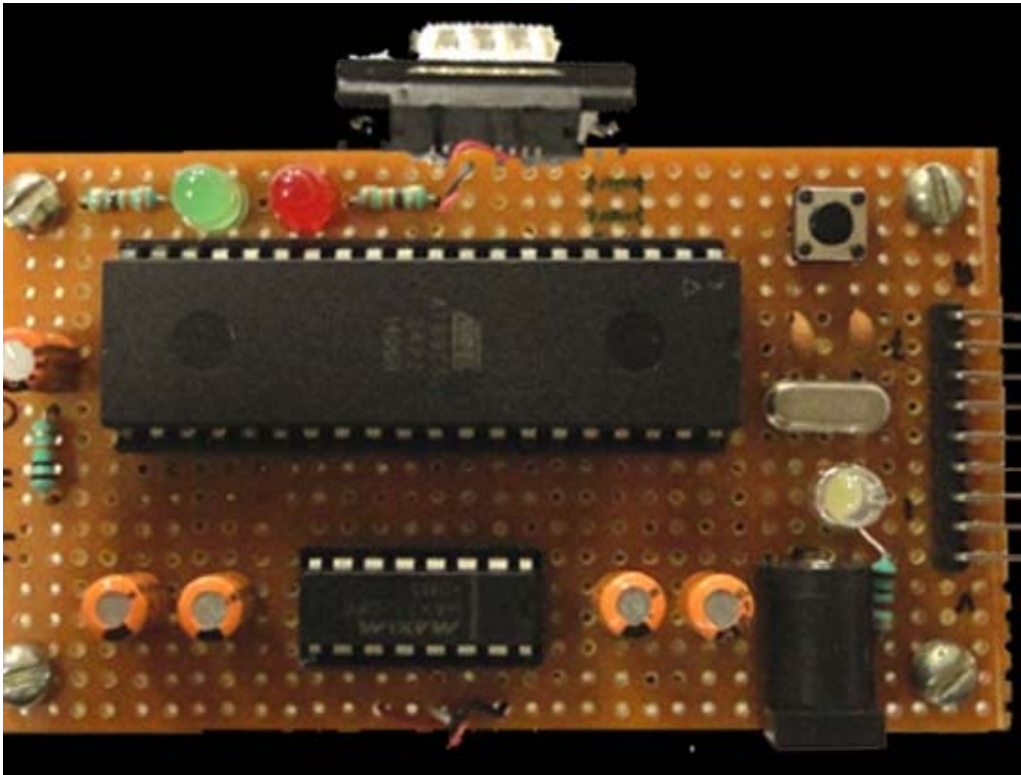

Figure 12: Main Controller Board

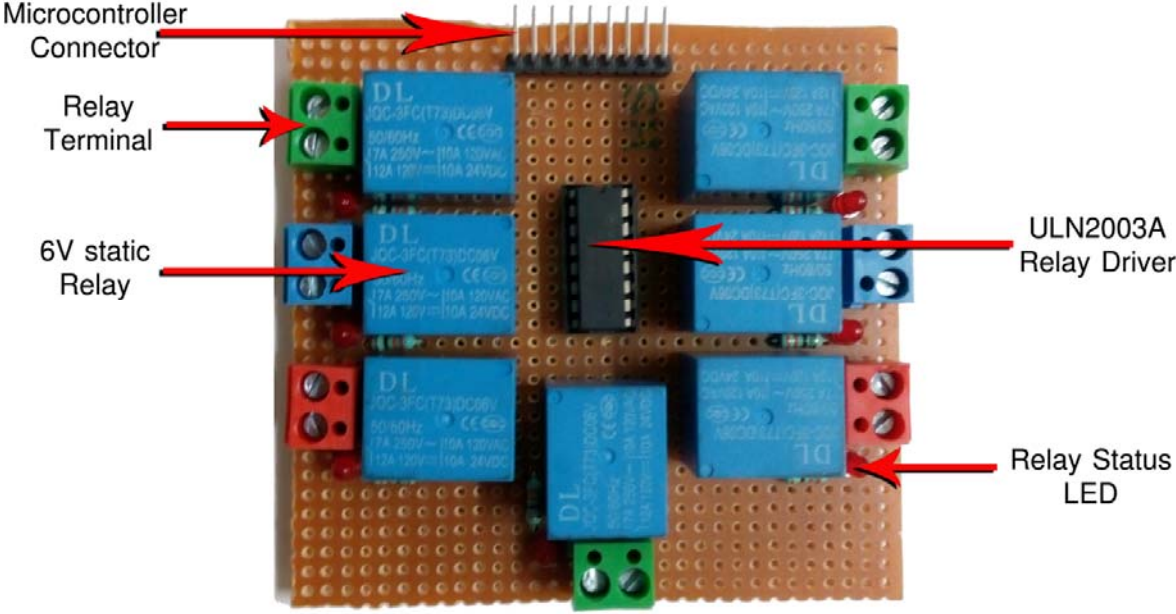

Figure 13: The Relay Board



Figure 14: Different messages on the LCD

```

BlueTerm 2                                     connected: COM1
Load Switching using RS 232 Bluetooth Module
Design by Project Group 1
|----|----|----|----|----|----|----|----|----|----|
Enter password to continue =* * * *
WRONG PASSWORD
Enter password to continue = * * * *
Load Status (0-OFF, 1-ON) = 0 0 0 0 0 0 0
Load Status (0-OFF, 1-ON) = 1 0 0 0 0 0 0
Load Status (0-OFF, 1-ON) = 1 0 1 0 0 0 0
Load Status (0-OFF, 1-ON) = 1 0 1 0 1 0 0
Load Status (0-OFF, 1-ON) = 1 0 1 0 1 0 1
Load Status (0-OFF, 1-ON) = 0 0 0 0 0 0 0
Load Status (0-OFF, 1-ON) = 1 1 1 1 1 1 1
Enter password to continue =*
WRONG PASSWORD
Enter password to continue = * * * *
Load Status (0-OFF, 1-ON) = 1 1 1 1 1 1 1
Load Status (0-OFF, 1-ON) = 0 1 1 1 1 1 1
Load Status (0-OFF, 1-ON) = 0 1 1 1 0 1 1
Load Status (0-OFF, 1-ON) = 0 1 1 1 0 1 0
Enter password to continue = * * * *
WRONG PASSWORD
Enter password to continue =

```

Figure 15: Complete setup of the Project



# **Chapter 6**

## **(Conclusion & Future Scope)**

## **6.1 CONCLUSION**

Here we are developed a 'RS-232 based secure home automation system' circuit which could be used for domestic load switching, it also limit the exceeding electricity bill. The circuit mainly consists of four parts such as RS-232 section, password check, audio and visual feedback, switching on and off the loads. When a command is given to the microcontroller AT89c51 it immediately changes the state of the load. The commands that are being passed through the microcontroller are in the form of ASCII code. When a specific ASCII code is passed, the status of the load is changed and a feedback is given to the microcontroller regarding the status of the load that is being displayed on the LCD. The whole system is password protected. If the controller receives the correct password, then it actuates the relay driver. The relay driver drives the relay to switch on/off the domestic electrical loads.

## **6.2 RESULTS**

The experimental model was made according to the circuit diagram and the results were as expected. The loads are switched on when the password are correct and the respective buttons for each of the loads are pressed. The loads are switched off only when the respective buttons of the on loads are pressed again.

## **6.3 FUTURE WORK**

Presently we are using a serial port hyper terminal for giving the required ASCII command but in future plan we will develop a user interface using visual basic to control the loads through PC. The user interface will also show the present status of the connecting loads. Moreover, we want to implement continuous control. For this we have to generate Pulse Width Modulation (PWM).

# **Chapter 7**

## **(References)**

1. 1. Bamigboye, O & Ehiagwina, Frederick & Kehinde, Olufemi & Kifli, Adebayo,"Development of a PC Based Home Automation System For Appliances Control",2016.
2. Anamul, H. M., & Kamruzzaman, S. M. ," Microprocessor and interfacing and hardware", 2nd ed., 2013.
3. Casimiro, A., Kaiser, J., & Verissimo, P., "An architecture framework and middleware for control architecture for home automation system in the internet era. Proceeding of ICRA Cooperating Smart Components", (pp. 28-39), Italy, 2011.
4. Kim, T., Lee, H., & Chung, Y, "Advanced universal remote controller for home automation and security", IEEE Transaction on Consumer Electronics, 56(4), 2537-2542, 2010
5. Koyuncu, B., "PC remote control of appliances by using telephone lines", IEEE Transaction on Consumer Electronics, 41(1), 201-209, 2005
6. Laxmi Soni et al Int. Journal of Engineering Research and Applications ISSN : 2248- 9622, Vol. 4, Issue 5( Version 1), pp.51-53, May 2014.
7. Dinesh Suresh Bhadane, Monali D. Wani, Sanjeev. A. Shukla, Aniket R. Yeole, "A review on home control automation using GSM and Bluetooth", International Journal of Advanced Research in Computer Science and Software Engineering, Volume 5, Issue 2, February 2015
8. Sharon Panth, Mahesh Jivani, "Home Automation System (HAS) using Android for Mobile Phone", International Journal of Electronics and Computer Science Engineering, ISSN: 2277-1956

# **Appendix A**

## **(Hardware description)**

## Transformer less AC to DC power supply circuit using dropping capacitor

Production of low voltage DC power supply from AC power is the most important problem faced by many electronics developers and hobbyists. The straight forward technique is the use of a step down transformer to reduce the 230 V or 110V AC to a preferred level of low voltage AC. But *SMPS* power supply comes with the most appropriate method to create a low cost power supply by avoiding the use of bulky transformer. This circuit is so simple and it uses a voltage dropping capacitor in series with the phase line. Transformer less power supply is also called as capacitor power supply. It can generate 5V, 6V, 12V 150mA from 230V or 110V AC by using appropriate zener diodes.

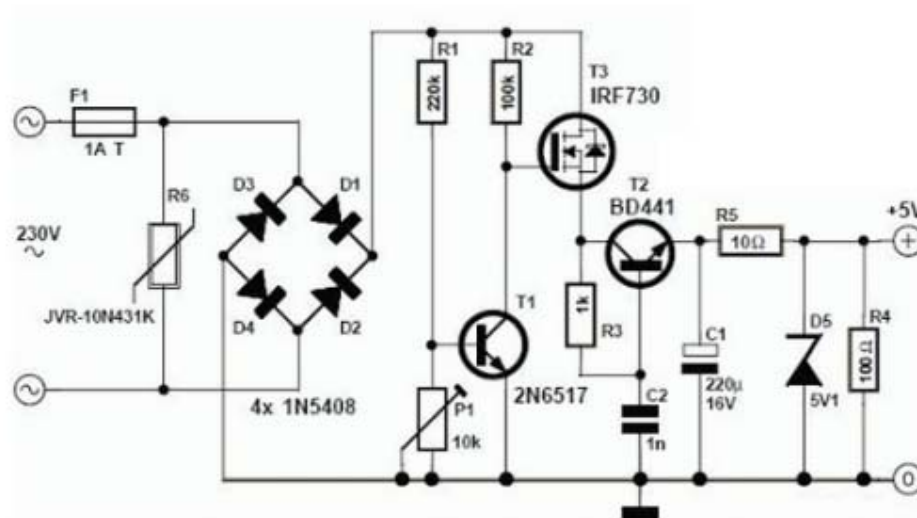

Figure 16: Transformer less SMPS 5 volt power supply

### Working of Transformer less capacitor power supply

- This transformer less power supply circuit is also named as capacitor power supply since it uses a special type of AC capacitor in series with the main power line.
- A common capacitor will not do the work because the mains spikes will generate holes in the dielectric and the capacitor will be cracked by passing of current from the mains through the capacitor.
- X rated capacitor suitable for the use in AC mains is vital for reducing AC voltage.
- A X rated dropping capacitor is intended for 250V, 400V, 600V AC. Higher voltage versions are also obtainable. The dropping capacitor is non polarized so that it can be connected any way in the circuit.
- The 470kΩ resistor is a bleeder resistor that removes the stored current from the capacitor when the circuit is unplugged. It avoids the possibility of electric shock.
- Reduced AC voltage is rectified by bridge rectifier circuit. We have already discussed about bridge rectifiers. Then the ripples are removed by the 1000µF capacitor.

- This circuit provides 24 volts at 160 mA current at the output. This 24 volt DC can be regulated to necessary output voltage using an appropriate 1 watt or above zener diode.
- Here we are using 6.2V zener. You can use any type of zener diode in order to get the required output voltage.

## AT 89c51 Microcontroller

AT89C51 is an 8-bit microcontroller and belongs to Atmel's 8051 family. **ATMEL 89C51** has 4KB of Flash programmable and erasable read only memory (PEROM) and 128 bytes of RAM. It can be erased and program to a maximum of 1000 times.

In 40 pin AT89C51, there are four ports designated as P<sub>1</sub>, P<sub>2</sub>, P<sub>3</sub> and P<sub>0</sub>. All these ports are 8-bit bi-directional ports, *i.e.*, they can be used as both input and output ports. Except P<sub>0</sub> which needs external pull-ups, rest of the ports have internal pull-ups. When 1s are written to these port pins, they are pulled high by the internal pull-ups and can be used as inputs. These ports are also bit addressable and so their bits can also be accessed individually.

Port P<sub>0</sub> and P<sub>2</sub> are also used to provide low byte and high byte addresses, respectively, when connected to an external memory. Port 3 has multiplexed pins for special functions like serial communication, hardware interrupts, timer inputs and read/write operation from external memory. AT89C51 has an inbuilt UART for serial communication. It can be programmed to operate at different baud rates. Including two timers & hardware interrupts, it has a total of six interrupts.

### PIN Diagram:

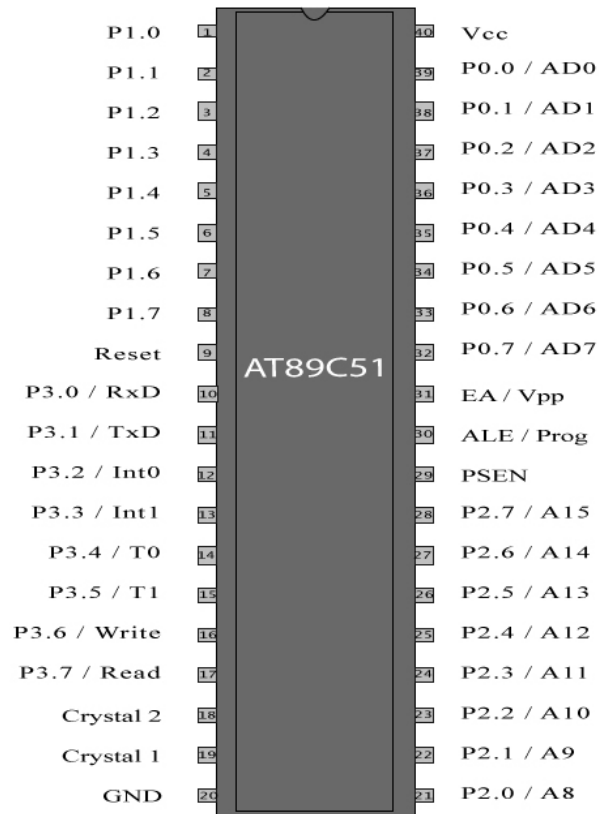

Figure 17: 89c51 Microcontroller Pin Diagram

**PIN Description:**

Pin No	Function		Name
1	8 bit input/output port (P <sub>1</sub> ) pins		P <sub>1.0</sub>
2			P <sub>1.1</sub>
3			P <sub>1.2</sub>
4			P <sub>1.3</sub>
5			P <sub>1.4</sub>
6			P <sub>1.5</sub>
7			P <sub>1.6</sub>
8			P <sub>1.7</sub>
9	Reset pin; Active high		Reset
10	Input (receiver) for serial communication	RxD	8 bit input/output port (P <sub>3</sub> ) pins
11	Output (transmitter) for serial communication	TxD	
12	External interrupt 1	Int0	
13	External interrupt 2	Int1	
14	Timer1 external input	T <sub>0</sub>	
15	Timer2 external input	T <sub>1</sub>	
16	Write to external data memory	Write	
17	Read from external data memory	Read	
18	Quartz crystal oscillator (up to 24 MHz)		Crystal 2
19			Crystal 1
20	Ground (0V)		Ground
21	8 bit input/output port (P <sub>2</sub> ) pins / High-order address bits when interfacing with external memory		P <sub>2.0</sub> / A <sub>8</sub>
22			P <sub>2.1</sub> / A <sub>9</sub>
23			P <sub>2.2</sub> / A <sub>10</sub>
24			P <sub>2.3</sub> / A <sub>11</sub>
25			P <sub>2.4</sub> / A <sub>12</sub>
26			P <sub>2.5</sub> / A <sub>13</sub>
27			P <sub>2.6</sub> / A <sub>14</sub>
28			P <sub>2.7</sub> / A <sub>15</sub>
29	Program store enable; Read from external program memory		PSEN
30	Address Latch Enable		ALE
	Program pulse input during Flash programming		Prog
31	External Access Enable; V <sub>cc</sub> for internal program executions		EA
	Programming enable voltage; 12V (during Flash programming)		V <sub>pp</sub>
32	8 bit input/output port (P <sub>0</sub> ) pins / Low-order address bits when interfacing with external memory		P <sub>0.7</sub> / AD <sub>7</sub>
33			P <sub>0.6</sub> / AD <sub>6</sub>
34			P <sub>0.5</sub> / AD <sub>5</sub>
35			P <sub>0.4</sub> / AD <sub>4</sub>
36			P <sub>0.3</sub> / AD <sub>3</sub>
37			P <sub>0.2</sub> / AD <sub>2</sub>
38			P <sub>0.1</sub> / AD <sub>1</sub>
39			P <sub>0.0</sub> / AD <sub>0</sub>
40	Supply voltage; 5V (up to 6.6V)		V <sub>cc</sub>

Table 5: Pin Description of 89c51 microcontroller



## 16x2 LCD Module:

- 16 character 2 lines display
- 4 bit and 8 bit data transfer mode
- display alpha numeric display
- backlight compatible
- contrast adjustment
- backlight intensity adjustment
- 5 volt operation
- compatible to almost every microcontroller

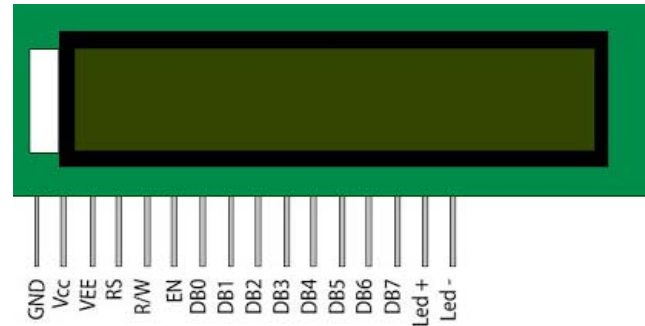

Figure 18: 16X2 LCD Module

## LCD Pin outs

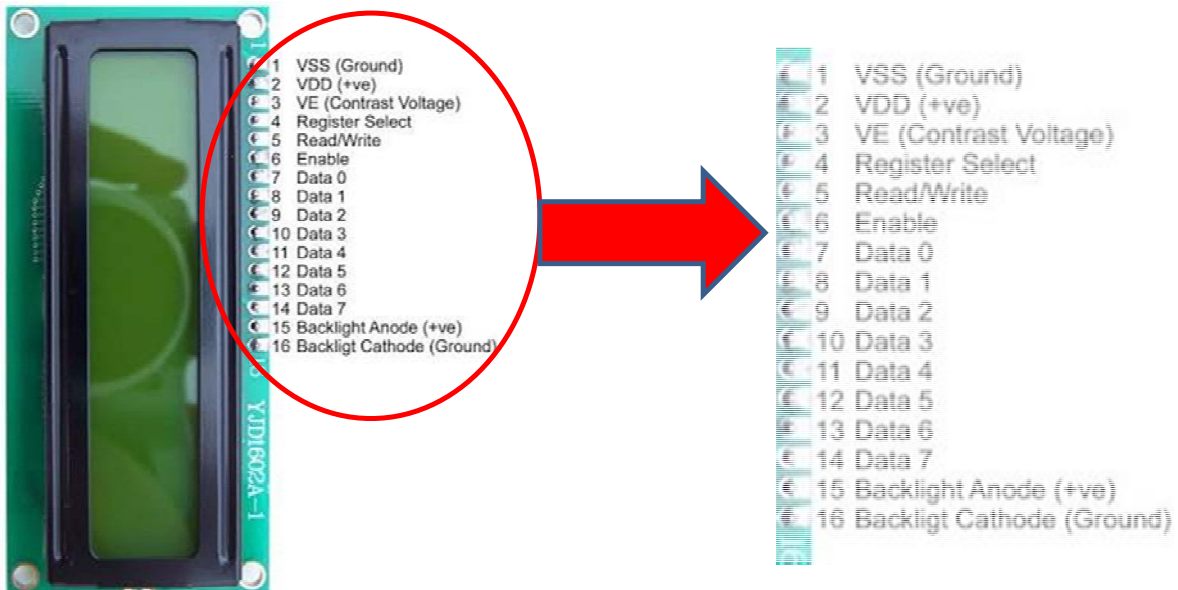

Figure 19: LCD Pin Diagram

## Relay Driver

- The ULN2003 is a monolithic high voltage and high current Darlington transistor arrays.
- It consists of seven NPN Darlington pairs that features high-voltage outputs with common-cathode clamp diode for switching inductive loads.
- The collector-current rating of a single Darlington pair is 500mA.
- The ULN functions as an inverter.
- If the logic at input 1B is high then the output at its corresponding pin 1C will be low.

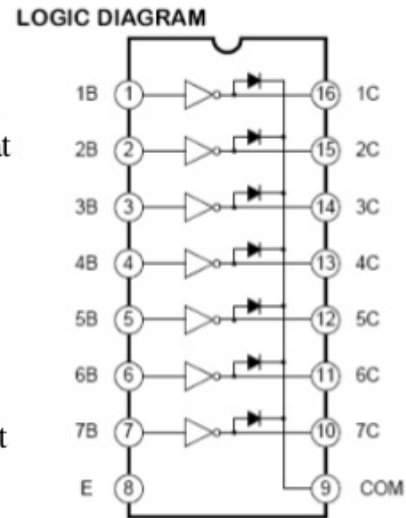

Figure 20: ULN2003A Internal Block Diagram

## Resistor



Figure 21: Resistor

Resistance is the opposition of a material to the current. It is measured in Ohms  $\Omega$ . All conductors represent a certain amount of resistance, since no conductor is 100% efficient. To control the electron flow (current) in a predictable manner, we use resistors. Electronic circuits use calibrated lumped resistance to control the flow of current. Broadly speaking, resistor can be divided into two groups viz. fixed & adjustable (variable) resistors. In fixed resistors, the value is fixed & cannot be varied. In variable resistors, the resistance value can be varied by an adjuster knob. It can be divided into (a) Carbon composition (b) Wire wound (c) Special type. The most common type of resistors used in our projects is carbon type. The resistance value is normally indicated by color bands. Each resistance has four colors, one of the band on either side will be gold or silver, this is called fourth band and indicates the tolerance, others three band will give the value of resistance (see table). For example if a resistor has the following marking on it say red, violet, gold. Comparing these colored rings with the color code, its value is 27000 ohms or 27 kilo ohms and its tolerance is  $\pm 5\%$ . Resistor comes in various sizes (Power rating). The bigger the size, the more power rating of 1/4 watts. The four color rings on its body tells us the value of resistor value.

## Color Code of the resistor

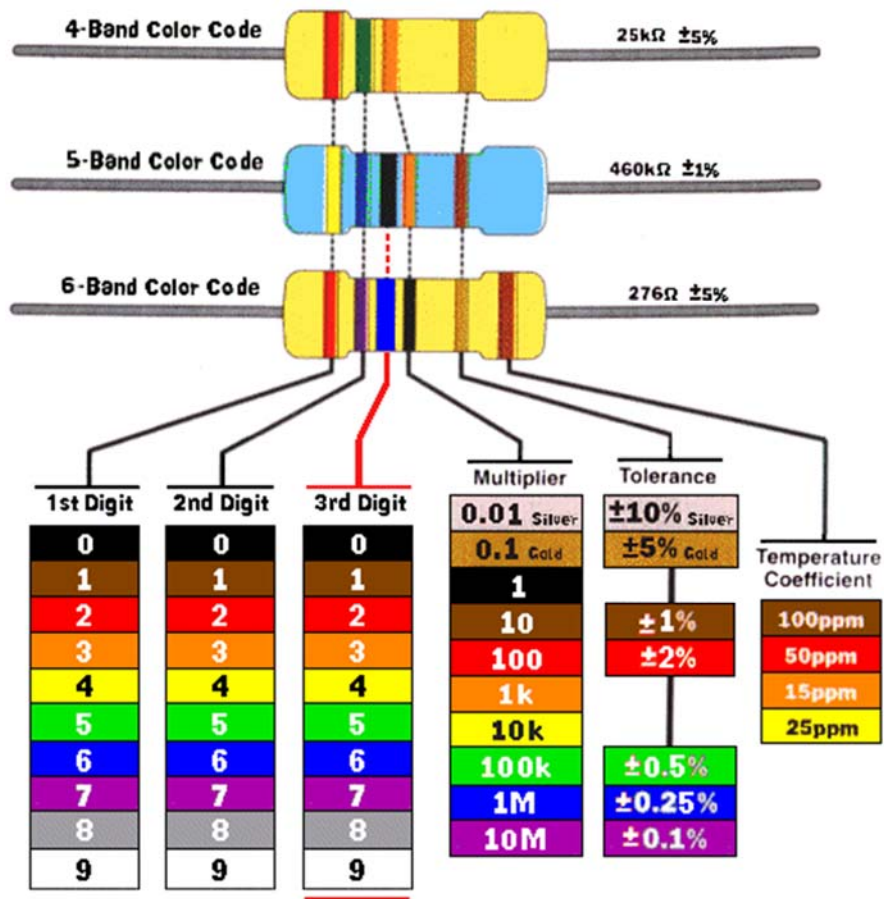

Figure 22: Color Code for resistance

# RELAY

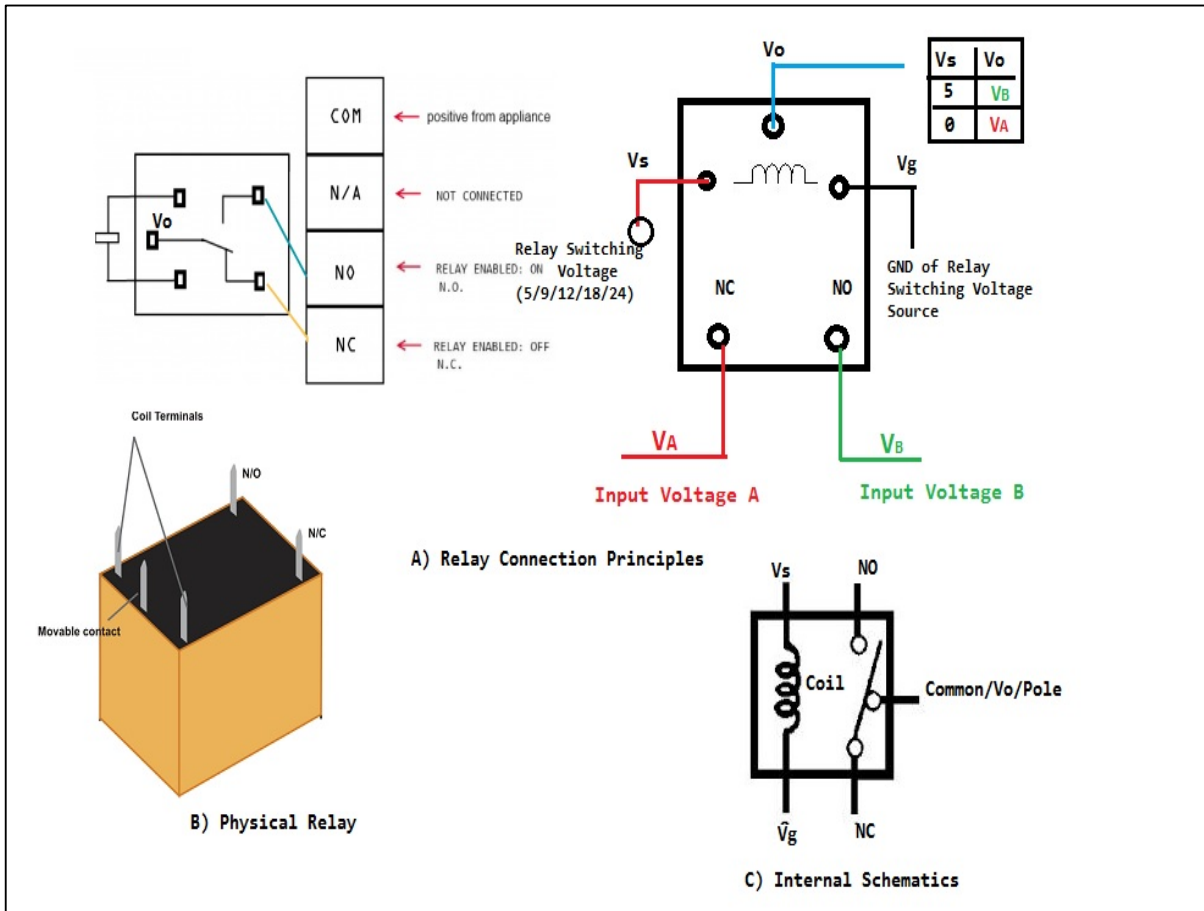

Figure 23: 6 volt Cube Relay

A relay is an electrically operated switch. Current flowing through the coil of the relay creates a magnetic field which attracts a lever and changes the switch contacts. The coil current can be on or off so relays have two switch positions and they are double throw (changeover) switches.

The relay's switch connections are usually labeled COM (POLE), NC and NO:

COM/POLE= Common, NC and NO always connect to this, it is the moving part of the switch.

NC = Normally Closed, COM/POLE is connected to this when the relay coil is not magnetized.

NO = Normally Open, COM/POLE is connected to this when the relay coil is MAGNETIZED and vice versa.

## Capacitors

It is an electronic component whose function is to accumulate charges and then release it.

To understand the concept of capacitance, consider a pair of metal plates which all are placed near to each other without touching. If a battery is connected to these plates the positive pole to one and the negative pole to the other, electrons from the



Figure 24: Types of capacitors

battery will be attracted from the plate connected to the positive terminal of the battery. If the battery is then disconnected, one plate will be left with an excess of electrons, the other with a shortage, and a potential or voltage difference will exist between them. These plates will be acting as capacitors. Capacitors are of two types: - (1) **fixed type** like ceramic, polyester, electrolytic capacitors - these names refer to the material they are made of aluminum foil. (2) **Variable type** like gang condenser in radio or trimmer. In fixed type capacitors, it has two leads and its value is written over its body and variable type has three leads. Unit of measurement of a capacitor is farad denoted by the symbol F. It is a very big unit of capacitance. Small unit capacitor are pico-farad denoted by pf ( $1\text{pf}=1/1000,000,000,000\text{ f}$ ) Above all, in case of electrolytic capacitors, its two terminals are marked as (-) and (+).

## Crystal Oscillator

A crystal oscillator is an electronic oscillator circuit that uses the mechanical resonance of a vibrating crystal of piezoelectric material to create an electrical signal with a precise frequency. This frequency is commonly used to keep track of time, as in quartz wristwatches, to provide a stable clock signal for digital integrated circuits, and to stabilize frequencies for radio transmitters and receivers. The most common type of piezoelectric resonator used is the quartz crystal, so oscillator circuits incorporating them became known as crystal oscillators, but other piezoelectric materials including polycrystalline ceramics are used in similar circuits.



Figure 25: Crystal Oscillator

Quartz crystals are manufactured for frequencies from a few tens of kilohertz to hundreds of megahertz. More than two billion crystals are manufactured annually. Most are used for consumer devices such as wristwatches, clocks, radios, computers, and cell phones. Quartz crystals are also found inside test and measurement equipment, such as counters, signal generators, and oscilloscopes.

### **Piezo buzzer**

A buzzer or beeper is an audio signaling device, which may be mechanical, electromechanical, or piezoelectric. Typical uses of buzzers and beepers include alarm devices, timers and confirmation of user input such as a mouse click or keystroke. A piezoelectric element may be driven by an oscillating electronic circuit or other audio signal source, driven with a piezoelectric audio amplifier. Sounds commonly used to indicate that a button has been pressed are a click, a ring or a beep.



Figure 26: Piezo Buzzer

### **Blank PCB**

A **printed circuit board (PCB)** mechanically supports and electrically connects electronic components using conductive tracks, pads and other features etched from copper sheets laminated onto a non-conductive substrate. PCBs can be *single sided* (one copper layer), *double sided* (two copper layers) or *multi-layer* (outer and inner layers). Multi-layer PCBs allow for much higher component density. Conductors on different layers are connected with plated-through holes called vias. Advanced PCBs may contain components - capacitors, resistors or active devices - embedded in the substrate.

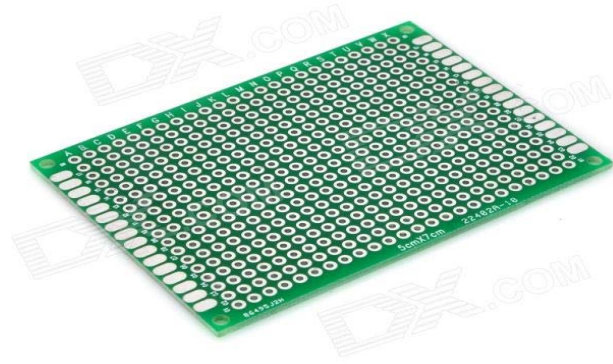

Figure 27: Blank glass epoxy PCB Board

FR-4 glass epoxy is the primary insulating substrate upon which the vast majority of rigid PCBs are produced. A thin layer of copper foil is laminated to one or both sides of an FR-4 panel. Circuitry interconnections are etched into copper layers to produce printed circuit boards. Complex circuits are produced in multiple layers.

Printed circuit boards are used in all but the simplest electronic products. Alternatives to PCBs include wire wrap and point-to-point construction. PCBs require the additional design effort to lay out the circuit, but manufacturing and assembly can be automated. Manufacturing circuits with PCBs is cheaper and faster than with other wiring methods as components are mounted and wired with one single part. Furthermore, operator wiring errors are eliminated.

# **Appendix B**

## **(Software coding)**



# PROGRAM CODE:

```

; Home Automation using RS232 (serial
communication)
;-----
ORG 00H
MOV P2, #00H
SETB P3.6 ;Green LED off
CLR P3.7 ;Red LED ON
START:
MOV A, #0DH
ACALL TRANS
mov TMOD,#20h ;Timer 2 (8 bit auto reload
mode)
mov TH1,#0FDH ;9600 Baud rate in
11.0592 MHz Crystal
mov SCON,#50h
setb TR1
MOV DPTR, #MYDATA ; Load Switching
through PC Project Display
H_1: CLR A
MOVC A, @A+DPTR
JZ B_1
ACALL TRANS
INC DPTR
SJMP H_1
B_1:
MOV A, #0DH ; for 'ENTER'
ACALL TRANS
MOV DPTR, #MYDATA1 ; Based on Serial
Communication with RS232 Display
H_2: CLR A
MOVC A, @A+DPTR
JZ B_2
ACALL TRANS
INC DPTR
SJMP H_2
B_2:
MOV A, #0DH ; for 'ENTER'
ACALL TRANS
MOV DPTR, #MYDATA2 ; Design by
Budhaditya Biswas Display
H_3: CLR A
MOVC A, @A+DPTR
JZ B_3
ACALL TRANS
INC DPTR
SJMP H_3
B_3:
SETB P3.6 ;Green LED off
CLR P3.7 ;Red LED ON
MOV A, #0DH ; for 'ENTER'
ACALL TRANS
MOV DPTR, #MYDATA3 ; Enter password
to continue = Display
H_4: CLR A
MOVC A, @A+DPTR
JZ ENTER
ACALL TRANS
INC DPTR
SJMP H_4
;-----
; password enter section
;-----
ENTER: MOV R5, #29H ;Initially wrong value
loaded
ENTER1:
ACALL RECEIVE
CJNE A, #0DH, ADD1
SJMP CHECK
ADD1: SUBB A, #30H
MOV R5, A
ACALL STAR
ACALL RECEIVE
CJNE A, #0DH, ADD2
SJMP CHECK
ADD2: SUBB A, #30H
SWAP A
ADD A, R5
MOV R5, A
ACALL STAR
ACALL RECEIVE
CJNE A, #0DH, ADD3
SJMP CHECK
ADD3: SUBB A, #30H
MOV R6, A
ACALL STAR
ACALL RECEIVE
CJNE A, #0DH, ADD4
SJMP CHECK
ADD4: SUBB A, #30H
SWAP A
ADD A, R6
MOV R6, A
ACALL STAR
SJMP ENTER1
;-----
; password checking section (default password
9537)
;-----
CHECK:
MOV A, R5
CJNE A, #59H, Wrong
MOV A, R6
CJNE A, #73H, Wrong
CLR P3.6 ;Green LED ON
SETB P3.7 ;Red LED OFF
LJMP LOAD_1

```

```

WRONG:  MOV DPTR, #MYDATA4      ;
WRONG PASSWORD Display
H_5:    CLR A
        MOVC A, @A+DPTR
        CJNE A, #00H, ADD5
        LJMP B_3
ADD5:   ACALL TRANS
        INC DPTR
        SJMP H_5
;-----
;
;                               Load Switching Section
;-----
LOAD_1:
ACALL LOAD

SWITCH: ACALL RECEIVE
        CJNE A, #31H, ADD6
        CPL P2.0
        ACALL LOAD
        SJMP SWITCH

ADD6:   CJNE A, #32H, ADD7
        CPL P2.1
        ACALL LOAD
        SJMP SWITCH

ADD7:   CJNE A, #33H, ADD8
        CPL P2.2
        ACALL LOAD
        SJMP SWITCH

ADD8:   CJNE A, #34H, ADD9
        CPL P2.3
        ACALL LOAD
        SJMP SWITCH

ADD9:   CJNE A, #35H, ADD11
        CPL P2.4
        ACALL LOAD
        SJMP SWITCH

ADD11:  CJNE A, #36H, ADD12
        CPL P2.5
        ACALL LOAD
        SJMP SWITCH

ADD12:  CJNE A, #37H, ADD13
        CPL P2.6
        ACALL LOAD
        SJMP SWITCH

ADD13:  CJNE A, #38H, ADD10
        MOV P2, #00H
        ACALL LOAD
        SJMP SWITCH

ADD10:  CJNE A, #39H, SWITCH
        LJMP B_3
;-----
;
;                               Password appears as star
;-----
STAR:
        mov TMOD,#20h          ;Timer 2 (8 bit auto reload
                               mode)
        mov TH1,#0FDH          ;9600 Baud rate in
                               11.0592 MHz Crystal
        mov SCON,#50h
        setb TR1
        MOV A, #2AH            ;HEX for '*'
        ACALL TRANS
        MOV A, #20H            ;HEX for 'space'
        ACALL TRANS
RET
;-----
;                               Transmission & Receive subroutine
;-----
TRANS:
        MOV SBUF, A
        JNB TI, $
        CLR TI
RET

RECEIVE:
        JNB RI, $
        clr RI
        mov A, SBUF
RET
;-----
;                               Load status display
;-----
LOAD:
        MOV DPTR, #MYDATA5     ; Load Status (0-
                               OFF, 1-ON) = Display
H_6:    CLR A
        MOVC A, @A+DPTR
        JZ LOADDISP
        ACALL TRANS
        INC DPTR
        SJMP H_6

LoadDisp:
        MOV A, P2
        ANL A, #01H
        CJNE A, #01H, L_1
        MOV A, #31H
        ACALL TRANS
        MOV A, #02H
        ACALL TRANS
        SJMP L_2
L_1:    MOV A, #30H
        ACALL TRANS
        MOV A, #02H
        ACALL TRANS
L_2:    MOV A, P2
        ANL A, #02H
        CJNE A, #02H, L_3
        MOV A, #31H
        ACALL TRANS
        MOV A, #02H

```

```

ACALL TRANS
SJMP L_4
L_3:    MOV A, #30H
        ACALL TRANS
        MOV A, #02H
        ACALL TRANS

L_4:    MOV A, P2
        ANL A, #04H
        CJNE A, #04H, L_5
        MOV A, #31H
        ACALL TRANS
        MOV A, #02H
        ACALL TRANS
        SJMP L_6

L_5:    MOV A, #30H
        ACALL TRANS
        MOV A, #02H
        ACALL TRANS

L_6:    MOV A, P2
        ANL A, #08H
        CJNE A, #08H, L_7
        MOV A, #31H
        ACALL TRANS
        MOV A, #02H
        ACALL TRANS
        SJMP L_8

L_7:    MOV A, #30H
        ACALL TRANS
        MOV A, #02H
        ACALL TRANS

L_8:    MOV A, P2
        ANL A, #10H
        CJNE A, #10H, L_9
        MOV A, #31H
        ACALL TRANS
        MOV A, #02H
        ACALL TRANS
        SJMP L_10

L_9:    MOV A, #30H
        ACALL TRANS
        MOV A, #02H

```

```

ACALL TRANS

L_10:   MOV A, P2
        ANL A, #20H
        CJNE A, #20H, L_11
        MOV A, #31H
        ACALL TRANS
        MOV A, #02H
        ACALL TRANS
        SJMP L_12

L_11:   MOV A, #30H
        ACALL TRANS
        MOV A, #02H
        ACALL TRANS

L_12:   MOV A, P2
        ANL A, #40H
        CJNE A, #40H, L_13
        MOV A, #31H
        ACALL TRANS
        MOV A, #02H
        ACALL TRANS
        SJMP L_14

L_13:   MOV A, #30H
        ACALL TRANS
        MOV A, #02H
        ACALL TRANS

L_14:
RET
;-----
MYDATA:    DB '      Load Switching through
PC Project', 0
MYDATA1:  DB '      Based on Serial Communication with
RS232', 0
MYDATA2:  DB '      Design by Project Group 1', 0DH,
' |---|---|---|---|---|---|---|---|', 0
MYDATA3:  DB 0DH, 'Enter password to continue = ', 0
MYDATA4:  DB 0DH, '      WRONG PASSWORD', 0
MYDATA5:  DB 0DH, 0DH, 'Load Status (0-OFF, 1-ON) =
', 0
;-----
END

```

# **Appendix C**

## **(Data sheets)**

## Features

- Compatible with MCS-51™ Products
- 2K Bytes of Reprogrammable Flash Memory
  - Endurance: 1,000 Write/Erase Cycles
- 2.7V to 6V Operating Range
- Fully Static Operation: 0 Hz to 24 MHz
- Two-level Program Memory Lock
- 128 x 8-bit Internal RAM
- 15 Programmable I/O Lines
- Two 16-bit Timer/Counters
- Six Interrupt Sources
- Programmable Serial UART Channel
- Direct LED Drive Outputs
- On-chip Analog Comparator
- Low-power Idle and Power-down Modes

## Description

The AT89C2051 is a low-voltage, high-performance CMOS 8-bit microcomputer with 2K bytes of Flash programmable and erasable read only memory (PEROM). The device is manufactured using Atmel's high-density nonvolatile memory technology and is compatible with the industry-standard MCS-51 instruction set. By combining a versatile 8-bit CPU with Flash on a monolithic chip, the Atmel AT89C2051 is a powerful microcomputer which provides a highly-flexible and cost-effective solution to many embedded control applications.

The AT89C2051 provides the following standard features: 2K bytes of Flash, 128 bytes of RAM, 15 I/O lines, two 16-bit timer/counters, a five vector two-level interrupt architecture, a full duplex serial port, a precision analog comparator, on-chip oscillator and clock circuitry. In addition, the AT89C2051 is designed with static logic for operation down to zero frequency and supports two software selectable power saving modes. The Idle Mode stops the CPU while allowing the RAM, timer/counters, serial port and interrupt system to continue functioning. The power-down mode saves the RAM contents but freezes the oscillator disabling all other chip functions until the next hardware reset.

## Pin Configuration

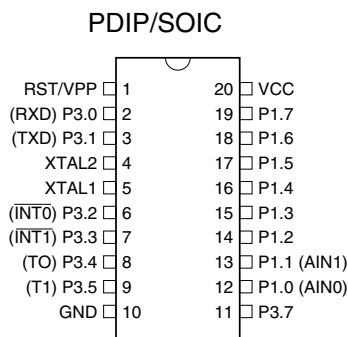

## 8-bit Microcontroller with 2K Bytes Flash

## AT89C2051



# Block Diagram

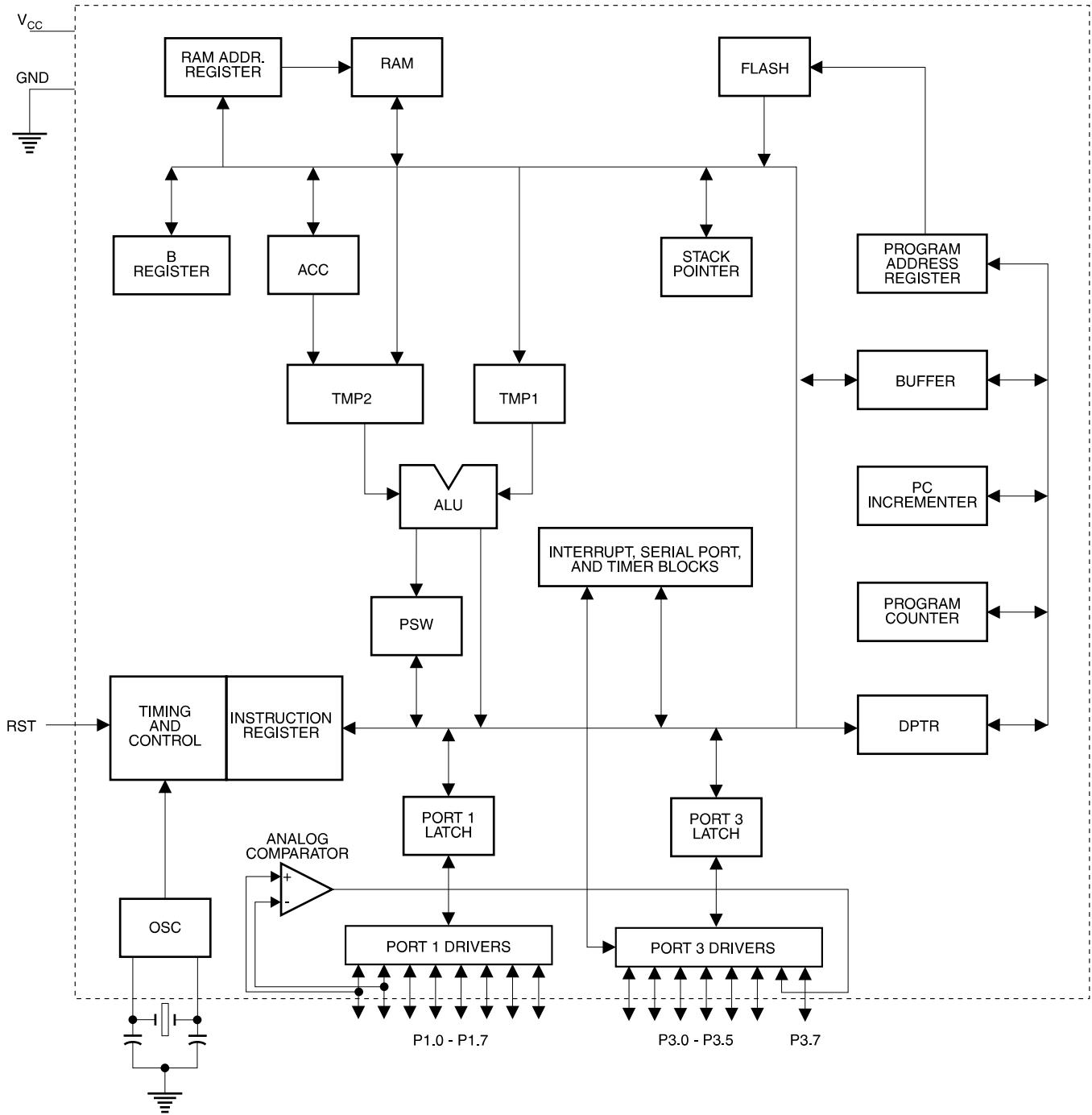

## Pin Description

### VCC

Supply voltage.

### GND

Ground.

### Port 1

Port 1 is an 8-bit bi-directional I/O port. Port pins P1.2 to P1.7 provide internal pullups. P1.0 and P1.1 require external pullups. P1.0 and P1.1 also serve as the positive input (AIN0) and the negative input (AIN1), respectively, of the on-chip precision analog comparator. The Port 1 output buffers can sink 20 mA and can drive LED displays directly. When 1s are written to Port 1 pins, they can be used as inputs. When pins P1.2 to P1.7 are used as inputs and are externally pulled low, they will source current ( $I_{IL}$ ) because of the internal pullups.

Port 1 also receives code data during Flash programming and verification.

### Port 3

Port 3 pins P3.0 to P3.5, P3.7 are seven bi-directional I/O pins with internal pullups. P3.6 is hard-wired as an input to the output of the on-chip comparator and is not accessible as a general purpose I/O pin. The Port 3 output buffers can sink 20 mA. When 1s are written to Port 3 pins they are pulled high by the internal pullups and can be used as inputs. As inputs, Port 3 pins that are externally being pulled low will source current ( $I_{IL}$ ) because of the pullups.

Port 3 also serves the functions of various special features of the AT89C2051 as listed below:

Port Pin	Alternate Functions
P3.0	RXD (serial input port)
P3.1	TXD (serial output port)
P3.2	$\overline{INT0}$ (external interrupt 0)
P3.3	$\overline{INT1}$ (external interrupt 1)
P3.4	T0 (timer 0 external input)
P3.5	T1 (timer 1 external input)

Port 3 also receives some control signals for Flash programming and verification.

### RST

Reset input. All I/O pins are reset to 1s as soon as RST goes high. Holding the RST pin high for two machine cycles while the oscillator is running resets the device.

Each machine cycle takes 12 oscillator or clock cycles.

### XTAL1

Input to the inverting oscillator amplifier and input to the internal clock operating circuit.

### XTAL2

Output from the inverting oscillator amplifier.

## Oscillator Characteristics

XTAL1 and XTAL2 are the input and output, respectively, of an inverting amplifier which can be configured for use as an on-chip oscillator, as shown in Figure 1. Either a quartz crystal or ceramic resonator may be used. To drive the device from an external clock source, XTAL2 should be left unconnected while XTAL1 is driven as shown in Figure 2. There are no requirements on the duty cycle of the external clock signal, since the input to the internal clocking circuitry is through a divide-by-two flip-flop, but minimum and maximum voltage high and low time specifications must be observed.

**Figure 1.** Oscillator Connections

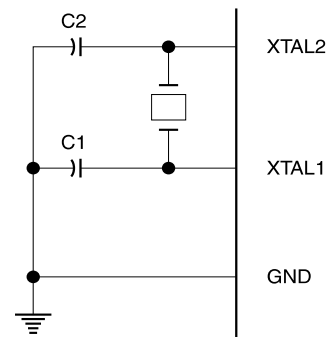

Note: C1, C2 = 30 pF ± 10 pF for Crystals  
= 40 pF ± 10 pF for Ceramic Resonators

**Figure 2.** External Clock Drive Configuration

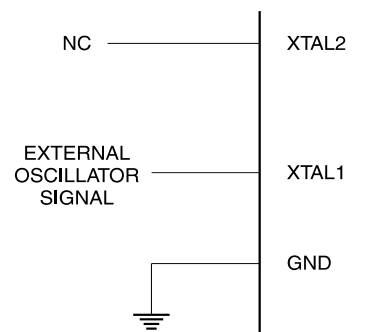



## Special Function Registers

A map of the on-chip memory area called the Special Function Register (SFR) space is shown in the table below.

Note that not all of the addresses are occupied, and unoccupied addresses may not be implemented on the chip. Read accesses to these addresses will in general return

random data, and write accesses will have an indeterminate effect.

User software should not write 1s to these unlisted locations, since they may be used in future products to invoke new features. In that case, the reset or inactive values of the new bits will always be 0.

**Table 1.** AT89C2051 SFR Map and Reset Values

0F8H								0FFH
0F0H	B 00000000							0F7H
0E8H								0EFH
0E0H	ACC 00000000							0E7H
0D8H								0DFH
0D0H	PSW 00000000							0D7H
0C8H								0CFH
0C0H								0C7H
0B8H	IP XXX00000							0BFH
0B0H	P3 11111111							0B7H
0A8H	IE 0XX00000							0AFH
0A0H								0A7H
98H	SCON 00000000	SBUF XXXXXXXX						9FH
90H	P1 11111111							97H
88H	TCON 00000000	TMOD 00000000	TL0 00000000	TL1 00000000	TH0 00000000	TH1 00000000		8FH
80H		SP 00000111	DPL 00000000	DPH 00000000			PCON 0XXX0000	87H



## Restrictions on Certain Instructions

The AT89C2051 and is an economical and cost-effective member of Atmel's growing family of microcontrollers. It contains 2K bytes of flash program memory. It is fully compatible with the MCS-51 architecture, and can be programmed using the MCS-51 instruction set. However, there are a few considerations one must keep in mind when utilizing certain instructions to program this device.

All the instructions related to jumping or branching should be restricted such that the destination address falls within the physical program memory space of the device, which is 2K for the AT89C2051. This should be the responsibility of the software programmer. For example, LJMP 7E0H would be a valid instruction for the AT89C2051 (with 2K of memory), whereas LJMP 900H would not.

### 1. Branching instructions:

LCALL, LJMP, ACALL, AJMP, SJMP, JMP @A+DPTR

These unconditional branching instructions will execute correctly as long as the programmer keeps in mind that the destination branching address must fall within the physical boundaries of the program memory size (locations 00H to 7FFH for the 89C2051). Violating the physical space limits may cause unknown program behavior.

CJNE [...], DJNZ [...], JB, JNB, JC, JNC, JBC, JZ, JNZ With these conditional branching instructions the same rule above applies. Again, violating the memory boundaries may cause erratic execution.

For applications involving interrupts the normal interrupt service routine address locations of the 80C51 family architecture have been preserved.

### 2. MOVX-related instructions, Data Memory:

The AT89C2051 contains 128 bytes of internal data memory. Thus, in the AT89C2051 the stack depth is limited to 128 bytes, the amount of available RAM. External DATA memory access is not supported in this device, nor is external PROGRAM memory execution. Therefore, no MOVX [...] instructions should be included in the program.

A typical 80C51 assembler will still assemble instructions, even if they are written in violation of the restrictions mentioned above. It is the responsibility of the controller user to know the physical features and limitations of the device being used and adjust the instructions used correspondingly.

## Program Memory Lock Bits

On the chip are two lock bits which can be left unprogrammed (U) or can be programmed (P) to obtain the additional features listed in the table below:

### Lock Bit Protection Modes<sup>(1)</sup>

Program Lock Bits			Protection Type
	LB1	LB2	
1	U	U	No program lock features.
2	P	U	Further programming of the Flash is disabled.
3	P	P	Same as mode 2, also verify is disabled.

Note: 1. The Lock Bits can only be erased with the Chip Erase operation.

## Idle Mode

In idle mode, the CPU puts itself to sleep while all the on-chip peripherals remain active. The mode is invoked by software. The content of the on-chip RAM and all the special functions registers remain unchanged during this mode. The idle mode can be terminated by any enabled interrupt or by a hardware reset.

P1.0 and P1.1 should be set to "0" if no external pullups are used, or set to "1" if external pullups are used.

It should be noted that when idle is terminated by a hardware reset, the device normally resumes program execution, from where it left off, up to two machine cycles before the internal reset algorithm takes control. On-chip hardware inhibits access to internal RAM in this event, but access to the port pins is not inhibited. To eliminate the possibility of an unexpected write to a port pin when Idle is terminated by reset, the instruction following the one that invokes Idle should not be one that writes to a port pin or to external memory.

## Power-down Mode

In the power down mode the oscillator is stopped, and the instruction that invokes power down is the last instruction executed. The on-chip RAM and Special Function Registers retain their values until the power down mode is terminated. The only exit from power down is a hardware reset. Reset redefines the SFRs but does not change the on-chip RAM. The reset should not be activated before  $V_{CC}$  is restored to its normal operating level and must be held active long enough to allow the oscillator to restart and stabilize.

P1.0 and P1.1 should be set to "0" if no external pullups are used, or set to "1" if external pullups are used.

## Programming The Flash

The AT89C2051 is shipped with the 2K bytes of on-chip PEROM code memory array in the erased state (i.e., contents = FFH) and ready to be programmed. The code memory array is programmed one byte at a time. *Once the array is programmed, to re-program any non-blank byte, the entire memory array needs to be erased electrically.*

**Internal Address Counter:** The AT89C2051 contains an internal PEROM address counter which is always reset to 000H on the rising edge of RST and is advanced by applying a positive going pulse to pin XTAL1.

**Programming Algorithm:** To program the AT89C2051, the following sequence is recommended.

1. Power-up sequence:  
Apply power between  $V_{CC}$  and GND pins  
Set RST and XTAL1 to GND
2. Set pin RST to "H"  
Set pin P3.2 to "H"
3. Apply the appropriate combination of "H" or "L" logic levels to pins P3.3, P3.4, P3.5, P3.7 to select one of the programming operations shown in the PEROM Programming Modes table.

To Program and Verify the Array:

4. Apply data for Code byte at location 000H to P1.0 to P1.7.
5. Raise RST to 12V to enable programming.
6. Pulse P3.2 once to program a byte in the PEROM array or the lock bits. The byte-write cycle is self-timed and typically takes 1.2 ms.
7. To verify the programmed data, lower RST from 12V to logic "H" level and set pins P3.3 to P3.7 to the appropriate levels. Output data can be read at the port P1 pins.
8. To program a byte at the next address location, pulse XTAL1 pin once to advance the internal address counter. Apply new data to the port P1 pins.
9. Repeat steps 5 through 8, changing data and advancing the address counter for the entire 2K bytes array or until the end of the object file is reached.
10. Power-off sequence:  
set XTAL1 to "L"  
set RST to "L"  
Turn  $V_{CC}$  power off

**Data Polling:** The AT89C2051 features  $\overline{\text{Data}}$  Polling to indicate the end of a write cycle. During a write cycle, an attempted read of the last byte written will result in the complement of the written data on P1.7. Once the write cycle has been completed, true data is valid on all outputs, and

the next cycle may begin.  $\overline{\text{Data}}$  Polling may begin any time after a write cycle has been initiated.

**Ready/Busy:** The Progress of byte programming can also be monitored by the RDY/BSY output signal. Pin P3.1 is pulled low after P3.2 goes High during programming to indicate BUSY. P3.1 is pulled High again when programming is done to indicate READY.

**Program Verify:** If lock bits LB1 and LB2 have not been programmed code data can be read back via the data lines for verification:

1. Reset the internal address counter to 000H by bringing RST from "L" to "H".
2. Apply the appropriate control signals for Read Code data and read the output data at the port P1 pins.
3. Pulse pin XTAL1 once to advance the internal address counter.
4. Read the next code data byte at the port P1 pins.
5. Repeat steps 3 and 4 until the entire array is read.

The lock bits cannot be verified directly. Verification of the lock bits is achieved by observing that their features are enabled.

**Chip Erase:** The entire PEROM array (2K bytes) and the two Lock Bits are erased electrically by using the proper combination of control signals and by holding P3.2 low for 10 ms. The code array is written with all "1"s in the Chip Erase operation and must be executed before any non-blank memory byte can be re-programmed.

**Reading the Signature Bytes:** The signature bytes are read by the same procedure as a normal verification of locations 000H, 001H, and 002H, except that P3.5 and P3.7 must be pulled to a logic low. The values returned are as follows.

(000H) = 1EH indicates manufactured by Atmel

(001H) = 21H indicates 89C2051

## Programming Interface

Every code byte in the Flash array can be written and the entire array can be erased by using the appropriate combination of control signals. The write operation cycle is self-timed and once initiated, will automatically time itself to completion.

All major programming vendors offer worldwide support for the Atmel microcontroller series. Please contact your local programming vendor for the appropriate software revision.

# MAX232, MAX232I DUAL EIA-232 DRIVERS/RECEIVERS

SLLS047L – FEBRUARY 1989 – REVISED MARCH 2004

- Meets or Exceeds TIA/EIA-232-F and ITU Recommendation V.28
- Operates From a Single 5-V Power Supply With 1.0- $\mu$ F Charge-Pump Capacitors
- Operates Up To 120 kbit/s
- Two Drivers and Two Receivers
- $\pm 30$ -V Input Levels
- Low Supply Current . . . 8 mA Typical
- ESD Protection Exceeds JESD 22
  - 2000-V Human-Body Model (A114-A)
- Upgrade With Improved ESD (15-kV HBM) and 0.1- $\mu$ F Charge-Pump Capacitors is Available With the MAX202
- Applications
  - TIA/EIA-232-F, Battery-Powered Systems, Terminals, Modems, and Computers

MAX232 . . . D, DW, N, OR NS PACKAGE  
MAX232I . . . D, DW, OR N PACKAGE  
(TOP VIEW)

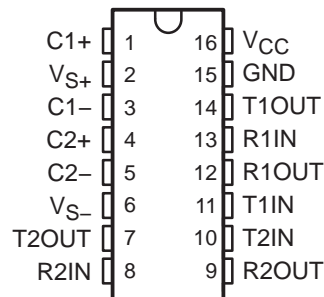

## description/ordering information

The MAX232 is a dual driver/receiver that includes a capacitive voltage generator to supply TIA/EIA-232-F voltage levels from a single 5-V supply. Each receiver converts TIA/EIA-232-F inputs to 5-V TTL/CMOS levels. These receivers have a typical threshold of 1.3 V, a typical hysteresis of 0.5 V, and can accept  $\pm 30$ -V inputs. Each driver converts TTL/CMOS input levels into TIA/EIA-232-F levels. The driver, receiver, and voltage-generator functions are available as cells in the Texas Instruments LinASIC™ library.

## ORDERING INFORMATION

TA	PACKAGE†		ORDERABLE PART NUMBER	TOP-SIDE MARKING
0°C to 70°C	PDIP (N)	Tube of 25	MAX232N	MAX232N
	SOIC (D)	Tube of 40	MAX232D	MAX232
		Reel of 2500	MAX232DR	
	SOIC (DW)	Tube of 40	MAX232DW	MAX232
		Reel of 2000	MAX232DWR	
SOP (NS)	Reel of 2000	MAX232NSR	MAX232	
-40°C to 85°C	PDIP (N)	Tube of 25	MAX232IN	MAX232IN
	SOIC (D)	Tube of 40	MAX232ID	MAX232I
		Reel of 2500	MAX232IDR	
	SOIC (DW)	Tube of 40	MAX232IDW	MAX232I
		Reel of 2000	MAX232IDWR	

† Package drawings, standard packing quantities, thermal data, symbolization, and PCB design guidelines are available at [www.ti.com/sc/package](http://www.ti.com/sc/package).



Please be aware that an important notice concerning availability, standard warranty, and use in critical applications of Texas Instruments semiconductor products and disclaimers thereto appears at the end of this data sheet.

LinASIC is a trademark of Texas Instruments.

PRODUCTION DATA information is current as of publication date. Products conform to specifications per the terms of Texas Instruments standard warranty. Production processing does not necessarily include testing of all parameters.



POST OFFICE BOX 655303 • DALLAS, TEXAS 75265

Copyright © 2004, Texas Instruments Incorporated

# MAX232, MAX232I DUAL EIA-232 DRIVERS/RECEIVERS

SLLS047L – FEBRUARY 1989 – REVISED MARCH 2004

## Function Tables

### EACH DRIVER

INPUT TIN	OUTPUT TOUT
L	H
H	L

H = high level, L = low level

### EACH RECEIVER

INPUT RIN	OUTPUT ROUT
L	H
H	L

H = high level, L = low level

## logic diagram (positive logic)

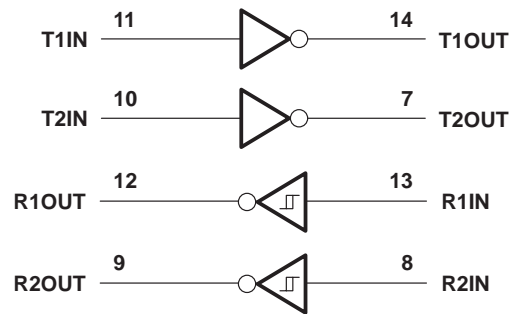

# MAX232, MAX232I DUAL EIA-232 DRIVERS/RECEIVERS

SLLS047L – FEBRUARY 1989 – REVISED MARCH 2004

## absolute maximum ratings over operating free-air temperature range (unless otherwise noted)†

Input supply voltage range, $V_{CC}$ (see Note 1)	–0.3 V to 6 V
Positive output supply voltage range, $V_{S+}$	$V_{CC} - 0.3$ V to 15 V
Negative output supply voltage range, $V_{S-}$	–0.3 V to –15 V
Input voltage range, $V_I$ : Driver	–0.3 V to $V_{CC} + 0.3$ V
Receiver	±30 V
Output voltage range, $V_O$ : T1OUT, T2OUT	$V_{S-} - 0.3$ V to $V_{S+} + 0.3$ V
R1OUT, R2OUT	–0.3 V to $V_{CC} + 0.3$ V
Short-circuit duration: T1OUT, T2OUT	Unlimited
Package thermal impedance, $\theta_{JA}$ (see Notes 2 and 3): D package	73°C/W
DW package	57°C/W
N package	67°C/W
NS package	64°C/W
Operating virtual junction temperature, $T_J$	150°C
Storage temperature range, $T_{stg}$	–65°C to 150°C

† Stresses beyond those listed under “absolute maximum ratings” may cause permanent damage to the device. These are stress ratings only, and functional operation of the device at these or any other conditions beyond those indicated under “recommended operating conditions” is not implied. Exposure to absolute-maximum-rated conditions for extended periods may affect device reliability.

- NOTES: 1. All voltages are with respect to network GND.  
 2. Maximum power dissipation is a function of  $T_{J(max)}$ ,  $\theta_{JA}$ , and  $T_A$ . The maximum allowable power dissipation at any allowable ambient temperature is  $P_D = (T_{J(max)} - T_A)/\theta_{JA}$ . Operating at the absolute maximum  $T_J$  of 150°C can affect reliability.  
 3. The package thermal impedance is calculated in accordance with JESD 51-7.

## recommended operating conditions

		MIN	NOM	MAX	UNIT
$V_{CC}$	Supply voltage	4.5	5	5.5	V
$V_{IH}$	High-level input voltage (T1IN, T2IN)	2			V
$V_{IL}$	Low-level input voltage (T1IN, T2IN)			0.8	V
R1IN, R2IN	Receiver input voltage			±30	V
$T_A$	Operating free-air temperature	MAX232		70	°C
		MAX232I	–40	85	

## electrical characteristics over recommended ranges of supply voltage and operating free-air temperature (unless otherwise noted) (see Note 4 and Figure 4)

PARAMETER	TEST CONDITIONS	MIN	TYP‡	MAX	UNIT
$I_{CC}$ Supply current	$V_{CC} = 5.5$ V, All outputs open, $T_A = 25^\circ\text{C}$		8	10	mA

‡ All typical values are at  $V_{CC} = 5$  V and  $T_A = 25^\circ\text{C}$ .

NOTE 4: Test conditions are C1–C4 = 1  $\mu\text{F}$  at  $V_{CC} = 5$  V  $\pm$  0.5 V.



# MAX232, MAX232I

## DUAL EIA-232 DRIVERS/RECEIVERS

SLLS047L – FEBRUARY 1989 – REVISED MARCH 2004

### DRIVER SECTION

electrical characteristics over recommended ranges of supply voltage and operating free-air temperature range (see Note 4)

PARAMETER		TEST CONDITIONS		MIN	TYP†	MAX	UNIT
V <sub>OH</sub>	High-level output voltage	T1OUT, T2OUT	R <sub>L</sub> = 3 kΩ to GND	5	7		V
V <sub>OL</sub>	Low-level output voltage‡	T1OUT, T2OUT	R <sub>L</sub> = 3 kΩ to GND		-7	-5	V
r <sub>o</sub>	Output resistance	T1OUT, T2OUT	V <sub>S+</sub> = V <sub>S-</sub> = 0, V <sub>O</sub> = ±2 V	300			Ω
I <sub>OS</sub> §	Short-circuit output current	T1OUT, T2OUT	V <sub>CC</sub> = 5.5 V, V <sub>O</sub> = 0		±10		mA
I <sub>IS</sub>	Short-circuit input current	T1IN, T2IN	V <sub>I</sub> = 0			200	μA

† All typical values are at V<sub>CC</sub> = 5 V, T<sub>A</sub> = 25°C.

‡ The algebraic convention, in which the least-positive (most negative) value is designated minimum, is used in this data sheet for logic voltage levels only.

§ Not more than one output should be shorted at a time.

NOTE 4: Test conditions are C1–C4 = 1 μF at V<sub>CC</sub> = 5 V ± 0.5 V.

switching characteristics, V<sub>CC</sub> = 5 V, T<sub>A</sub> = 25°C (see Note 4)

PARAMETER		TEST CONDITIONS	MIN	TYP	MAX	UNIT
SR	Driver slew rate	R <sub>L</sub> = 3 kΩ to 7 kΩ, See Figure 2			30	V/μs
SR(t)	Driver transition region slew rate	See Figure 3		3		V/μs
	Data rate	One TOUT switching		120		kbit/s

NOTE 4: Test conditions are C1–C4 = 1 μF at V<sub>CC</sub> = 5 V ± 0.5 V.

### RECEIVER SECTION

electrical characteristics over recommended ranges of supply voltage and operating free-air temperature range (see Note 4)

PARAMETER		TEST CONDITIONS		MIN	TYP†	MAX	UNIT
V <sub>OH</sub>	High-level output voltage	R1OUT, R2OUT	I <sub>OH</sub> = -1 mA	3.5			V
V <sub>OL</sub>	Low-level output voltage‡	R1OUT, R2OUT	I <sub>OL</sub> = 3.2 mA			0.4	V
V <sub>IT+</sub>	Receiver positive-going input threshold voltage	R1IN, R2IN	V <sub>CC</sub> = 5 V, T <sub>A</sub> = 25°C		1.7	2.4	V
V <sub>IT-</sub>	Receiver negative-going input threshold voltage	R1IN, R2IN	V <sub>CC</sub> = 5 V, T <sub>A</sub> = 25°C	0.8	1.2		V
V <sub>hys</sub>	Input hysteresis voltage	R1IN, R2IN	V <sub>CC</sub> = 5 V	0.2	0.5	1	V
r <sub>i</sub>	Receiver input resistance	R1IN, R2IN	V <sub>CC</sub> = 5, T <sub>A</sub> = 25°C	3	5	7	kΩ

† All typical values are at V<sub>CC</sub> = 5 V, T<sub>A</sub> = 25°C.

‡ The algebraic convention, in which the least-positive (most negative) value is designated minimum, is used in this data sheet for logic voltage levels only.

NOTE 4: Test conditions are C1–C4 = 1 μF at V<sub>CC</sub> = 5 V ± 0.5 V.

switching characteristics, V<sub>CC</sub> = 5 V, T<sub>A</sub> = 25°C (see Note 4 and Figure 1)

PARAMETER		TYP	UNIT
t <sub>PLH(R)</sub>	Receiver propagation delay time, low- to high-level output	500	ns
t <sub>PHL(R)</sub>	Receiver propagation delay time, high- to low-level output	500	ns

NOTE 4: Test conditions are C1–C4 = 1 μF at V<sub>CC</sub> = 5 V ± 0.5 V.



PARAMETER MEASUREMENT INFORMATION

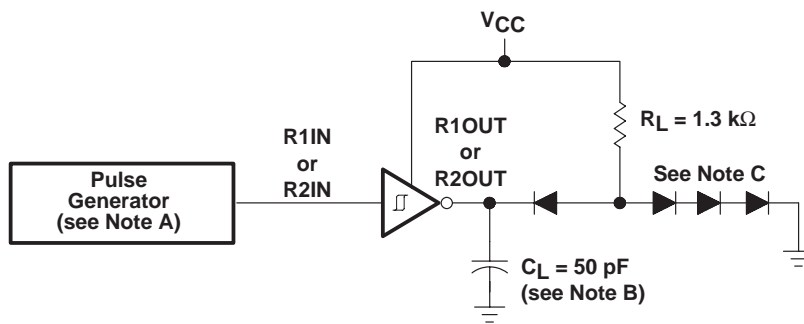

TEST CIRCUIT

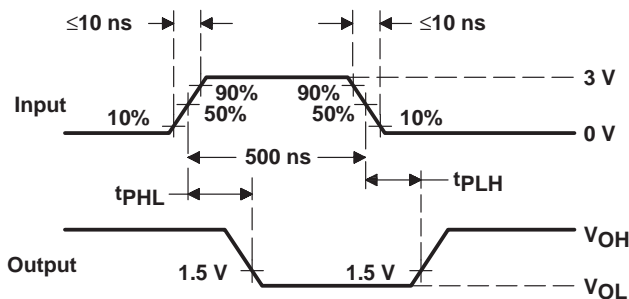

WAVEFORMS

- NOTES: A. The pulse generator has the following characteristics:  $Z_O = 50 \Omega$ , duty cycle  $\leq 50\%$ .  
 B.  $C_L$  includes probe and jig capacitance.  
 C. All diodes are 1N3064 or equivalent.

Figure 1. Receiver Test Circuit and Waveforms for  $t_{PHL}$  and  $t_{PLH}$  Measurements

# MAX232, MAX232I DUAL EIA-232 DRIVERS/RECEIVERS

SLLS047L – FEBRUARY 1989 – REVISED MARCH 2004

## PARAMETER MEASUREMENT INFORMATION

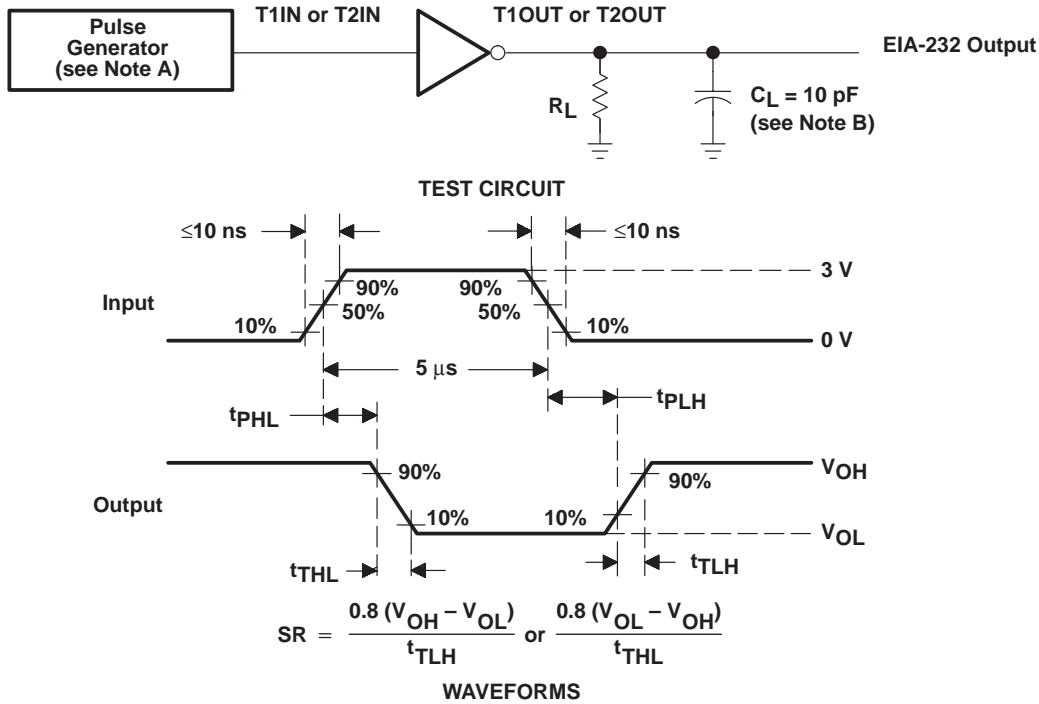

- NOTES: A. The pulse generator has the following characteristics:  $Z_O = 50 \Omega$ , duty cycle  $\leq 50\%$ .  
 B.  $C_L$  includes probe and jig capacitance.

Figure 2. Driver Test Circuit and Waveforms for  $t_{PHL}$  and  $t_{PLH}$  Measurements (5- $\mu$ s Input)

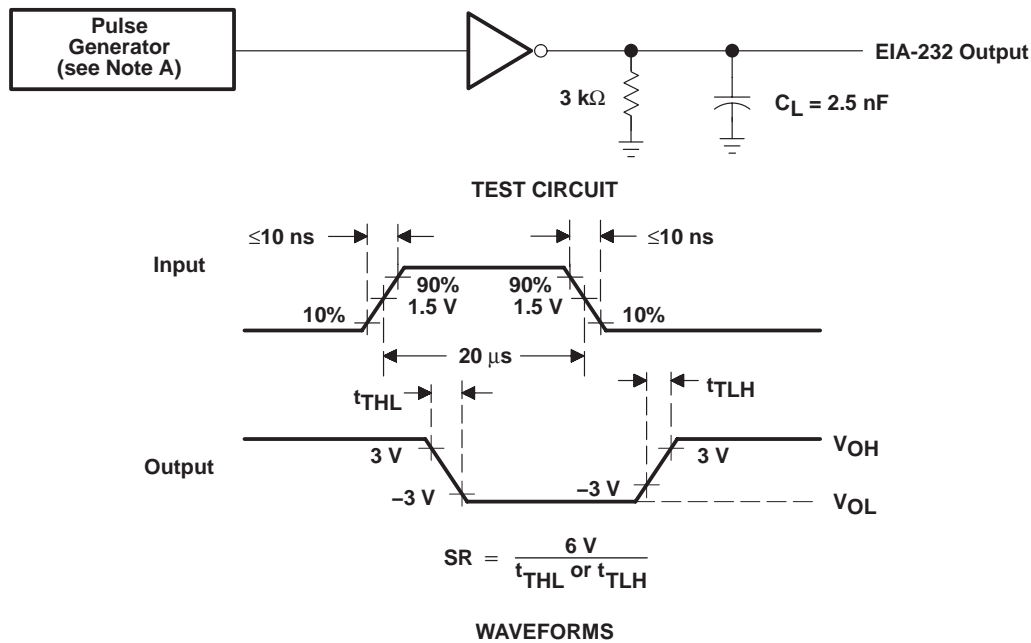

- NOTE A: The pulse generator has the following characteristics:  $Z_O = 50 \Omega$ , duty cycle  $\leq 50\%$ .

Figure 3. Test Circuit and Waveforms for  $t_{THL}$  and  $t_{TLH}$  Measurements (20- $\mu$ s Input)



APPLICATION INFORMATION

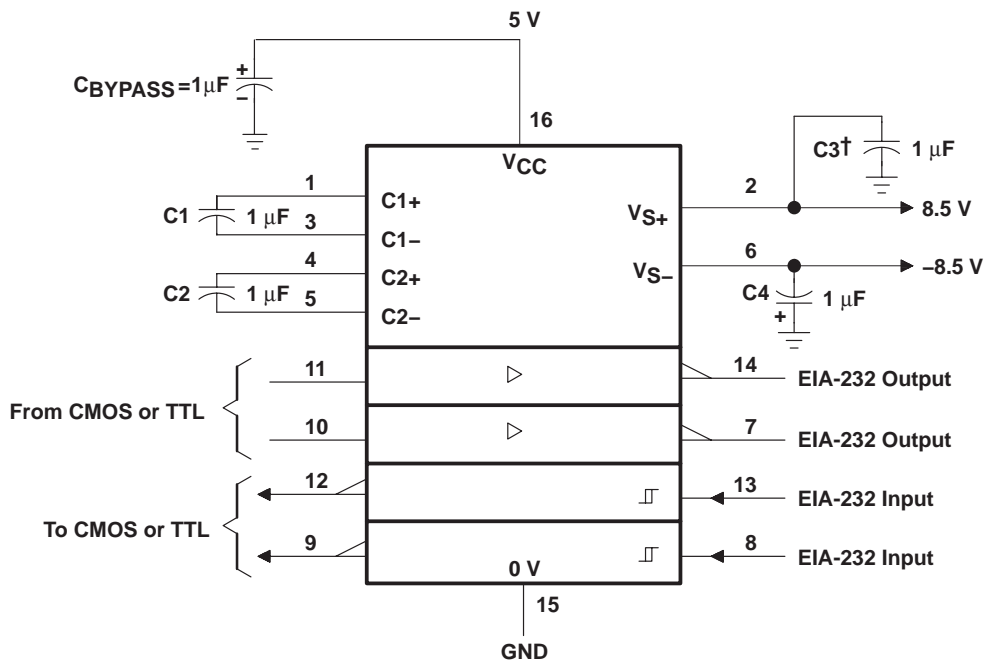

† C3 can be connected to V<sub>CC</sub> or GND.

NOTES: A. Resistor values shown are nominal.

B. Nonpolarized ceramic capacitors are acceptable. If polarized tantalum or electrolytic capacitors are used, they should be connected as shown. In addition to the 1-µF capacitors shown, the MAX202 can operate with 0.1-µF capacitors.

Figure 4. Typical Operating Circuit

**PACKAGING INFORMATION**

Orderable Device	Status <sup>(1)</sup>	Package Type	Package Drawing	Pins	Package Qty	Eco Plan <sup>(2)</sup>	Lead/Ball Finish	MSL Peak Temp <sup>(3)</sup>
MAX232D	ACTIVE	SOIC	D	16	40	Green (RoHS & no Sb/Br)	CU NIPDAU	Level-1-260C-UNLIM
MAX232DE4	ACTIVE	SOIC	D	16	40	Green (RoHS & no Sb/Br)	CU NIPDAU	Level-1-260C-UNLIM
MAX232DR	ACTIVE	SOIC	D	16	2500	Green (RoHS & no Sb/Br)	CU NIPDAU	Level-1-260C-UNLIM
MAX232DRE4	ACTIVE	SOIC	D	16	2500	Green (RoHS & no Sb/Br)	CU NIPDAU	Level-1-260C-UNLIM
MAX232DW	ACTIVE	SOIC	DW	16	40	Green (RoHS & no Sb/Br)	CU NIPDAU	Level-1-260C-UNLIM
MAX232DWE4	ACTIVE	SOIC	DW	16	40	Green (RoHS & no Sb/Br)	CU NIPDAU	Level-1-260C-UNLIM
MAX232DWR	ACTIVE	SOIC	DW	16	2000	Green (RoHS & no Sb/Br)	CU NIPDAU	Level-1-260C-UNLIM
MAX232DWRE4	ACTIVE	SOIC	DW	16	2000	Green (RoHS & no Sb/Br)	CU NIPDAU	Level-1-260C-UNLIM
MAX232ID	ACTIVE	SOIC	D	16	40	Green (RoHS & no Sb/Br)	CU NIPDAU	Level-1-260C-UNLIM
MAX232IDE4	ACTIVE	SOIC	D	16	40	Green (RoHS & no Sb/Br)	CU NIPDAU	Level-1-260C-UNLIM
MAX232IDR	ACTIVE	SOIC	D	16	2500	Green (RoHS & no Sb/Br)	CU NIPDAU	Level-1-260C-UNLIM
MAX232IDRE4	ACTIVE	SOIC	D	16	2500	Green (RoHS & no Sb/Br)	CU NIPDAU	Level-1-260C-UNLIM
MAX232IDW	ACTIVE	SOIC	DW	16	40	Green (RoHS & no Sb/Br)	CU NIPDAU	Level-1-260C-UNLIM
MAX232IDWE4	ACTIVE	SOIC	DW	16	40	Green (RoHS & no Sb/Br)	CU NIPDAU	Level-1-260C-UNLIM
MAX232IDWG4	ACTIVE	SOIC	DW	16	40	Green (RoHS & no Sb/Br)	CU NIPDAU	Level-1-260C-UNLIM
MAX232IDWR	ACTIVE	SOIC	DW	16	2000	Green (RoHS & no Sb/Br)	CU NIPDAU	Level-1-260C-UNLIM
MAX232IDWRE4	ACTIVE	SOIC	DW	16	2000	Green (RoHS & no Sb/Br)	CU NIPDAU	Level-1-260C-UNLIM
MAX232IDWRG4	ACTIVE	SOIC	DW	16	2000	Green (RoHS & no Sb/Br)	CU NIPDAU	Level-1-260C-UNLIM
MAX232IN	ACTIVE	PDIP	N	16	25	Pb-Free (RoHS)	CU NIPDAU	N / A for Pkg Type
MAX232INE4	ACTIVE	PDIP	N	16	25	Pb-Free (RoHS)	CU NIPDAU	N / A for Pkg Type
MAX232N	ACTIVE	PDIP	N	16	25	Pb-Free (RoHS)	CU NIPDAU	N / A for Pkg Type
MAX232NE4	ACTIVE	PDIP	N	16	25	Pb-Free (RoHS)	CU NIPDAU	N / A for Pkg Type
MAX232NSR	ACTIVE	SO	NS	16	2000	Green (RoHS & no Sb/Br)	CU NIPDAU	Level-1-260C-UNLIM
MAX232NSRE4	ACTIVE	SO	NS	16	2000	Green (RoHS & no Sb/Br)	CU NIPDAU	Level-1-260C-UNLIM

<sup>(1)</sup> The marketing status values are defined as follows:

---

**ACTIVE:** Product device recommended for new designs.

**LIFEBUY:** TI has announced that the device will be discontinued, and a lifetime-buy period is in effect.

**NRND:** Not recommended for new designs. Device is in production to support existing customers, but TI does not recommend using this part in a new design.

**PREVIEW:** Device has been announced but is not in production. Samples may or may not be available.

**OBSOLETE:** TI has discontinued the production of the device.

<sup>(2)</sup> Eco Plan - The planned eco-friendly classification: Pb-Free (RoHS), Pb-Free (RoHS Exempt), or Green (RoHS & no Sb/Br) - please check <http://www.ti.com/productcontent> for the latest availability information and additional product content details.

**TBD:** The Pb-Free/Green conversion plan has not been defined.

**Pb-Free (RoHS):** TI's terms "Lead-Free" or "Pb-Free" mean semiconductor products that are compatible with the current RoHS requirements for all 6 substances, including the requirement that lead not exceed 0.1% by weight in homogeneous materials. Where designed to be soldered at high temperatures, TI Pb-Free products are suitable for use in specified lead-free processes.

**Pb-Free (RoHS Exempt):** This component has a RoHS exemption for either 1) lead-based flip-chip solder bumps used between the die and package, or 2) lead-based die adhesive used between the die and leadframe. The component is otherwise considered Pb-Free (RoHS compatible) as defined above.

**Green (RoHS & no Sb/Br):** TI defines "Green" to mean Pb-Free (RoHS compatible), and free of Bromine (Br) and Antimony (Sb) based flame retardants (Br or Sb do not exceed 0.1% by weight in homogeneous material)

<sup>(3)</sup> MSL, Peak Temp. -- The Moisture Sensitivity Level rating according to the JEDEC industry standard classifications, and peak solder temperature.

**Important Information and Disclaimer:**The information provided on this page represents TI's knowledge and belief as of the date that it is provided. TI bases its knowledge and belief on information provided by third parties, and makes no representation or warranty as to the accuracy of such information. Efforts are underway to better integrate information from third parties. TI has taken and continues to take reasonable steps to provide representative and accurate information but may not have conducted destructive testing or chemical analysis on incoming materials and chemicals. TI and TI suppliers consider certain information to be proprietary, and thus CAS numbers and other limited information may not be available for release.

In no event shall TI's liability arising out of such information exceed the total purchase price of the TI part(s) at issue in this document sold by TI to Customer on an annual basis.

N (R-PDIP-T\*\*)

PLASTIC DUAL-IN-LINE PACKAGE

16 PINS SHOWN

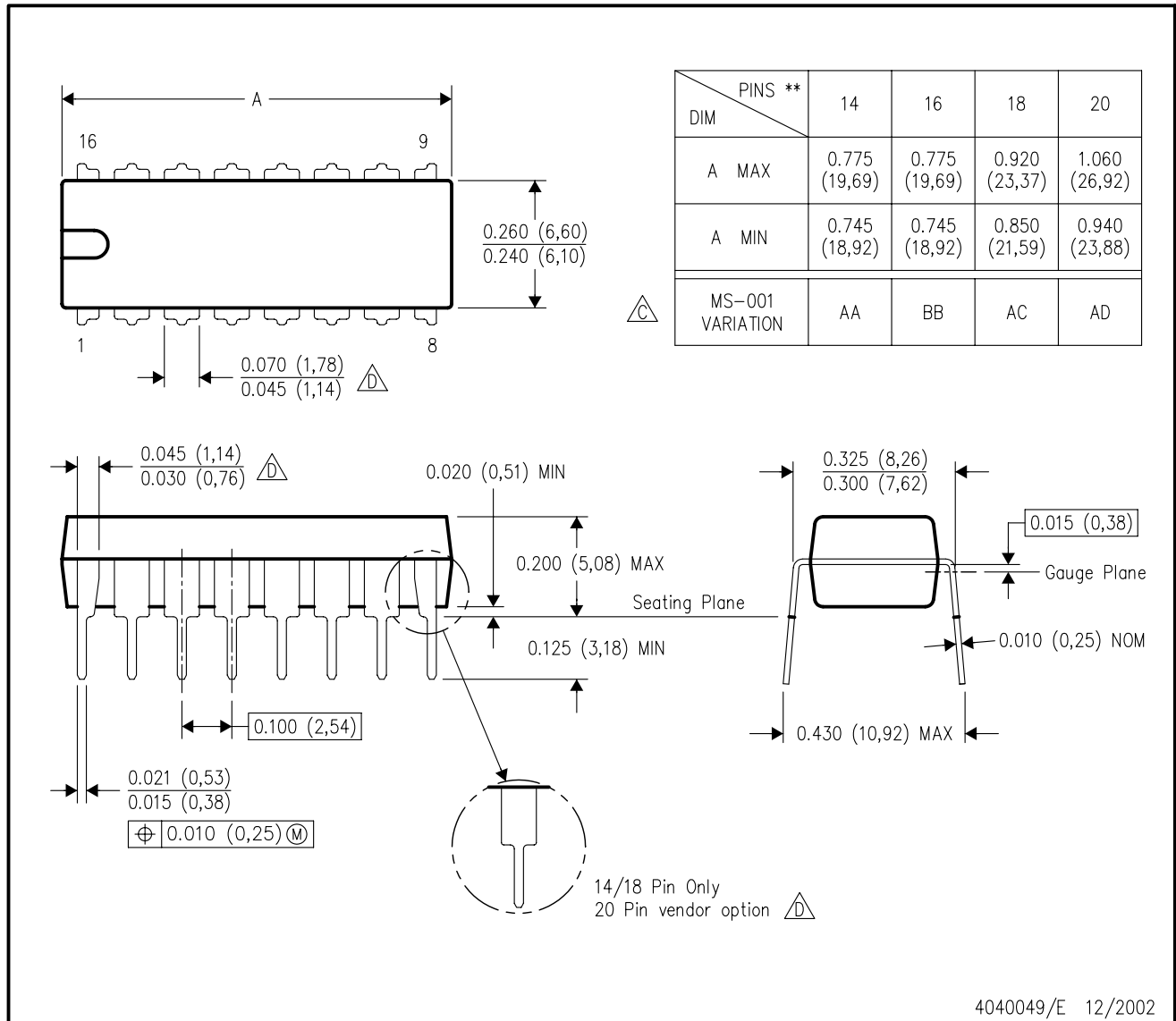

4040049/E 12/2002

- NOTES:
- A. All linear dimensions are in inches (millimeters).
  - B. This drawing is subject to change without notice.
  - $\triangle C$  Falls within JEDEC MS-001, except 18 and 20 pin minimum body length (Dim A).
  - $\triangle D$  The 20 pin end lead shoulder width is a vendor option, either half or full width.

D (R-PDSO-G16)

PLASTIC SMALL-OUTLINE PACKAGE

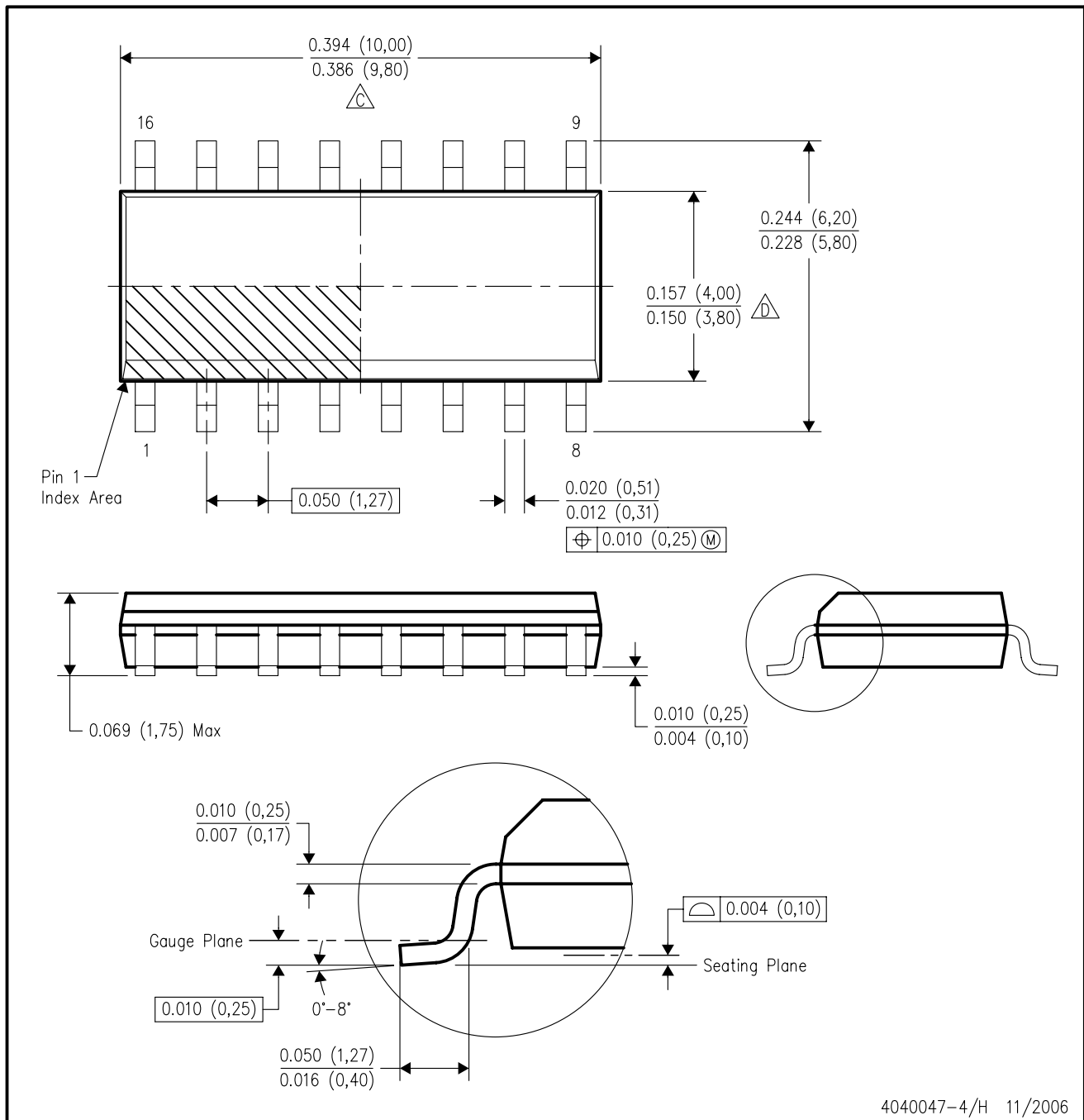

- NOTES:
- A. All linear dimensions are in inches (millimeters).
  - B. This drawing is subject to change without notice.
  - C. Body length does not include mold flash, protrusions, or gate burrs. Mold flash, protrusions, or gate burrs shall not exceed .006 (0,15) per end.
  - D. Body width does not include interlead flash. Interlead flash shall not exceed .017 (0,43) per side.
  - E. Reference JEDEC MS-012 variation AC.

DW (R-PDSO-G16)

PLASTIC SMALL-OUTLINE PACKAGE

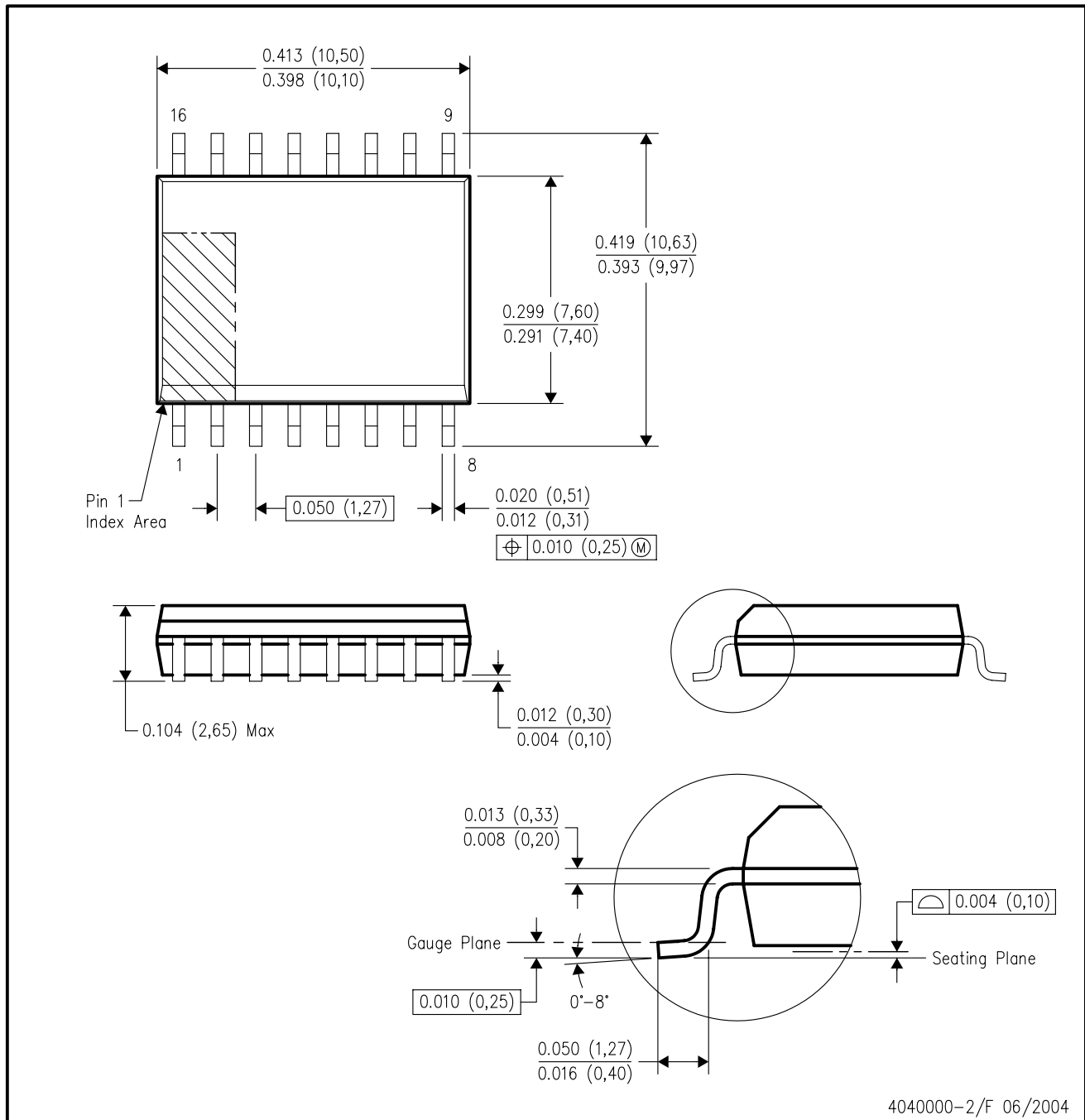

4040000-2/F 06/2004

- NOTES:
- A. All linear dimensions are in inches (millimeters).
  - B. This drawing is subject to change without notice.
  - C. Body dimensions do not include mold flash or protrusion not to exceed 0.006 (0,15).
  - D. Falls within JEDEC MS-013 variation AA.

# MECHANICAL DATA

NS (R-PDSO-G\*\*)

PLASTIC SMALL-OUTLINE PACKAGE

14-PINS SHOWN

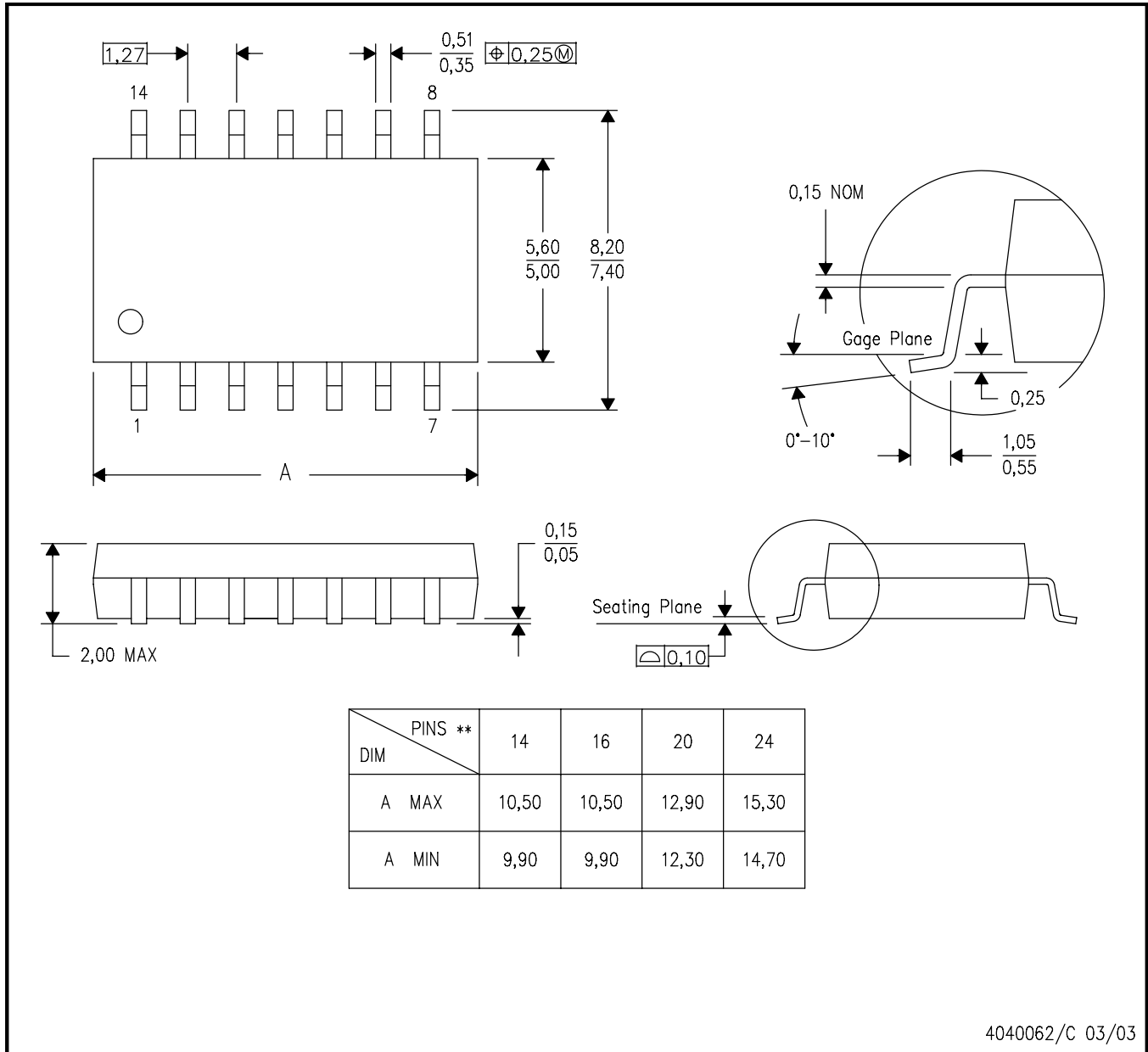

- NOTES:
- A. All linear dimensions are in millimeters.
  - B. This drawing is subject to change without notice.
  - C. Body dimensions do not include mold flash or protrusion, not to exceed 0,15.

## IMPORTANT NOTICE

Texas Instruments Incorporated and its subsidiaries (TI) reserve the right to make corrections, modifications, enhancements, improvements, and other changes to its products and services at any time and to discontinue any product or service without notice. Customers should obtain the latest relevant information before placing orders and should verify that such information is current and complete. All products are sold subject to TI's terms and conditions of sale supplied at the time of order acknowledgment.

TI warrants performance of its hardware products to the specifications applicable at the time of sale in accordance with TI's standard warranty. Testing and other quality control techniques are used to the extent TI deems necessary to support this warranty. Except where mandated by government requirements, testing of all parameters of each product is not necessarily performed.

TI assumes no liability for applications assistance or customer product design. Customers are responsible for their products and applications using TI components. To minimize the risks associated with customer products and applications, customers should provide adequate design and operating safeguards.

TI does not warrant or represent that any license, either express or implied, is granted under any TI patent right, copyright, mask work right, or other TI intellectual property right relating to any combination, machine, or process in which TI products or services are used. Information published by TI regarding third-party products or services does not constitute a license from TI to use such products or services or a warranty or endorsement thereof. Use of such information may require a license from a third party under the patents or other intellectual property of the third party, or a license from TI under the patents or other intellectual property of TI.

Reproduction of information in TI data books or data sheets is permissible only if reproduction is without alteration and is accompanied by all associated warranties, conditions, limitations, and notices. Reproduction of this information with alteration is an unfair and deceptive business practice. TI is not responsible or liable for such altered documentation.

Resale of TI products or services with statements different from or beyond the parameters stated by TI for that product or service voids all express and any implied warranties for the associated TI product or service and is an unfair and deceptive business practice. TI is not responsible or liable for any such statements.

Following are URLs where you can obtain information on other Texas Instruments products and application solutions:

<b>Products</b>		<b>Applications</b>	
Amplifiers	<a href="http://amplifier.ti.com">amplifier.ti.com</a>	Audio	<a href="http://www.ti.com/audio">www.ti.com/audio</a>
Data Converters	<a href="http://dataconverter.ti.com">dataconverter.ti.com</a>	Automotive	<a href="http://www.ti.com/automotive">www.ti.com/automotive</a>
DSP	<a href="http://dsp.ti.com">dsp.ti.com</a>	Broadband	<a href="http://www.ti.com/broadband">www.ti.com/broadband</a>
Interface	<a href="http://interface.ti.com">interface.ti.com</a>	Digital Control	<a href="http://www.ti.com/digitalcontrol">www.ti.com/digitalcontrol</a>
Logic	<a href="http://logic.ti.com">logic.ti.com</a>	Military	<a href="http://www.ti.com/military">www.ti.com/military</a>
Power Mgmt	<a href="http://power.ti.com">power.ti.com</a>	Optical Networking	<a href="http://www.ti.com/opticalnetwork">www.ti.com/opticalnetwork</a>
Microcontrollers	<a href="http://microcontroller.ti.com">microcontroller.ti.com</a>	Security	<a href="http://www.ti.com/security">www.ti.com/security</a>
Low Power Wireless	<a href="http://www.ti.com/lpw">www.ti.com/lpw</a>	Telephony	<a href="http://www.ti.com/telephony">www.ti.com/telephony</a>
		Video & Imaging	<a href="http://www.ti.com/video">www.ti.com/video</a>
		Wireless	<a href="http://www.ti.com/wireless">www.ti.com/wireless</a>

Mailing Address: Texas Instruments  
Post Office Box 655303 Dallas, Texas 75265



## ULN200x, ULQ200x High-Voltage, High-Current Darlington Transistor Arrays

### 1 Features

- 500-mA-Rated Collector Current (Single Output)
- High-Voltage Outputs: 50 V
- Output Clamp Diodes
- Inputs Compatible With Various Types of Logic
- Relay-Driver Applications

### 2 Applications

- Relay Drivers
- Stepper and DC Brushed Motor Drivers
- Lamp Drivers
- Display Drivers (LED and Gas Discharge)
- Line Drivers
- Logic Buffers

### 3 Description

The ULx200xA devices are high-voltage, high-current Darlington transistor arrays. Each consists of seven NPN Darlington pairs that feature high-voltage outputs with common-cathode clamp diodes for switching inductive loads.

The collector-current rating of a single Darlington pair is 500 mA. The Darlington pairs can be paralleled for higher current capability. Applications include relay drivers, hammer drivers, lamp drivers, display drivers (LED and gas discharge), line drivers, and logic buffers. For 100-V (otherwise interchangeable) versions of the ULx2003A devices, see the [SLRS023](#) data sheet for the SN75468 and SN75469 devices.

The ULN2002A device is designed specifically for use with 14-V to 25-V PMOS devices. Each input of this device has a Zener diode and resistor in series to control the input current to a safe limit. The ULx2003A devices have a 2.7-k $\Omega$  series base resistor for each Darlington pair for operation directly with TTL or 5-V CMOS devices.

The ULx2004A devices have a 10.5-k $\Omega$  series base resistor to allow operation directly from CMOS devices that use supply voltages of 6 V to 15 V. The required input current of the ULx2004A device is below that of the ULx2003A devices, and the required voltage is less than that required by the ULN2002A device.

Device Information<sup>(1)</sup>

PART NUMBER	PACKAGE	BODY SIZE (NOM)
ULx200xD	SOIC (16)	9.90 mm x 3.91 mm
ULx200xN	PDIP (16)	19.30 mm x 6.35 mm
ULN200xNS	SOP (16)	10.30 mm x 5.30 mm
ULN200xPW	TSSOP (16)	5.00 mm x 4.40 mm

(1) For all available packages, see the orderable addendum at the end of the data sheet.

Simplified Block Diagram

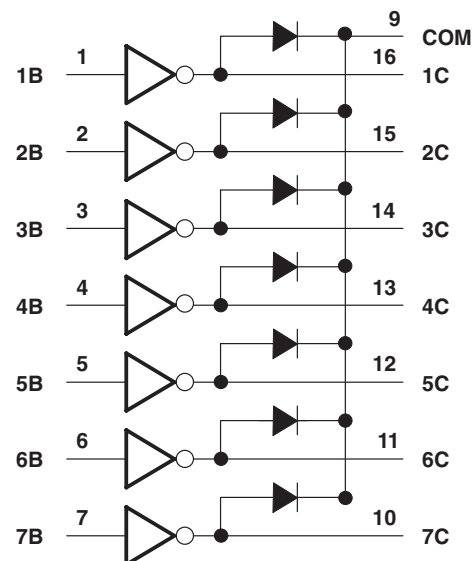

## Table of Contents

<b>1 Features</b> .....	<b>1</b>	<b>7 Parameter Measurement Information</b> .....	<b>10</b>
<b>2 Applications</b> .....	<b>1</b>	<b>8 Detailed Description</b> .....	<b>12</b>
<b>3 Description</b> .....	<b>1</b>	8.1 Overview .....	12
<b>4 Revision History</b> .....	<b>2</b>	8.2 Functional Block Diagrams .....	12
<b>5 Pin Configuration and Functions</b> .....	<b>3</b>	8.3 Feature Description .....	13
<b>6 Specifications</b> .....	<b>4</b>	8.4 Device Functional Modes .....	13
6.1 Absolute Maximum Ratings .....	4	<b>9 Application and Implementation</b> .....	<b>14</b>
6.2 ESD Ratings .....	4	9.1 Application Information .....	14
6.3 Recommended Operating Conditions .....	4	9.2 Typical Application .....	14
6.4 Thermal Information .....	4	9.3 System Examples .....	17
6.5 Electrical Characteristics: ULN2002A .....	5	<b>10 Power Supply Recommendations</b> .....	<b>18</b>
6.6 Electrical Characteristics: ULN2003A and ULN2004A .....	5	<b>11 Layout</b> .....	<b>18</b>
6.7 Electrical Characteristics: ULN2003AI .....	6	11.1 Layout Guidelines .....	18
6.8 Electrical Characteristics: ULN2003AI .....	6	11.2 Layout Example .....	18
6.9 Electrical Characteristics: ULQ2003A and ULQ2004A .....	7	<b>12 Device and Documentation Support</b> .....	<b>19</b>
6.10 Switching Characteristics: ULN2002A, ULN2003A, ULN2004A .....	7	12.1 Documentation Support .....	19
6.11 Switching Characteristics: ULN2003AI .....	7	12.2 Related Links .....	19
6.12 Switching Characteristics: ULN2003AI .....	8	12.3 Community Resources .....	19
6.13 Switching Characteristics: ULQ2003A, ULQ2004A .....	8	12.4 Trademarks .....	19
6.14 Typical Characteristics .....	8	12.5 Electrostatic Discharge Caution .....	19
		12.6 Glossary .....	19
		<b>13 Mechanical, Packaging, and Orderable Information</b> .....	<b>19</b>

## 4 Revision History

NOTE: Page numbers for previous revisions may differ from page numbers in the current version.

<b>Changes from Revision N (June 2015) to Revision O</b>	<b>Page</b>
• Changed Pin Functions table to correct typographical error. ....	<b>3</b>

<b>Changes from Revision M (February 2013) to Revision N</b>	<b>Page</b>
• Added <i>Pin Configuration and Functions</i> section, <i>ESD Ratings</i> table, <i>Feature Description</i> section, <i>Device Functional Modes</i> , <i>Application and Implementation</i> section, <i>Power Supply Recommendations</i> section, <i>Layout</i> section, <i>Device and Documentation Support</i> section, and <i>Mechanical, Packaging, and Orderable Information</i> section .....	<b>1</b>
• Deleted <i>Ordering Information</i> table. No specification changes. ....	<b>1</b>
• Moved <i>Typical Characteristics</i> into <i>Specifications</i> section. ....	<b>8</b>

<b>Changes from Revision L (April 2012) to Revision M</b>	<b>Page</b>
• Updated temperature rating for ULN2003AI in the ORDERING INFORMATION table .....	<b>1</b>

<b>Changes from Revision K (August 2011) to Revision L</b>	<b>Page</b>
• Removed reference to obsolete ULN2001 device .....	<b>1</b>

## 5 Pin Configuration and Functions

**D, N, NS, and PW Package  
16-Pin SOIC, PDIP, SO, and TSSOP  
Top View**

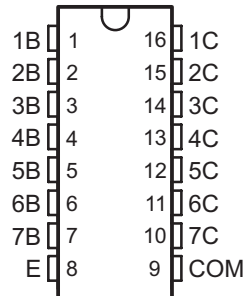

**Pin Functions**

PIN		I/O <sup>(1)</sup>	DESCRIPTION
NAME	NO.		
1B	1	I	Channel 1 through 7 Darlington base input
2B	2		
3B	3		
4B	4		
5B	5		
6B	6		
7B	7		
1C	16	O	Channel 1 through 7 Darlington collector output
2C	15		
3C	14		
4C	13		
5C	12		
6C	11		
7C	10		
COM	9	—	Common cathode node for flyback diodes (required for inductive loads)
E	8	—	Common emitter shared by all channels (typically tied to ground)

(1) I = Input, O = Output

## 6 Specifications

### 6.1 Absolute Maximum Ratings

at 25°C free-air temperature (unless otherwise noted)<sup>(1)</sup>

		MIN	MAX	UNIT	
V <sub>CC</sub>	Collector-emitter voltage		50	V	
	Clamp diode reverse voltage <sup>(2)</sup>		50	V	
V <sub>I</sub>	Input voltage <sup>(2)</sup>		30	V	
	Peak collector current, See <a href="#">Figure 4</a> and <a href="#">Figure 5</a>		500	mA	
I <sub>OK</sub>	Output clamp current		500	mA	
	Total emitter-terminal current		-2.5	A	
T <sub>A</sub>	Operating free-air temperature range	ULN200xA	-20	70	°C
		ULN200xAI	-40	105	
		ULQ200xA	-40	85	
		ULQ200xAT	-40	105	
T <sub>J</sub>	Operating virtual junction temperature		150	°C	
	Lead temperature for 1.6 mm (1/16 inch) from case for 10 seconds		260	°C	
T <sub>stg</sub>	Storage temperature	-65	150	°C	

- (1) Stresses beyond those listed under *Absolute Maximum Ratings* may cause permanent damage to the device. These are stress ratings only, and functional operation of the device at these or any other conditions beyond those indicated under *Recommended Operating Conditions* is not implied. Exposure to absolute-maximum-rated conditions for extended periods may affect device reliability.
- (2) All voltage values are with respect to the emitter/substrate terminal E, unless otherwise noted.

### 6.2 ESD Ratings

			VALUE	UNIT
V <sub>(ESD)</sub>	Electrostatic discharge	Human body model (HBM), per ANSI/ESDA/JEDEC JS-001 <sup>(1)</sup>	±2000	V
		Charged device model (CDM), per JEDEC specification JESD22-C101 <sup>(2)</sup>	±500	

- (1) JEDEC document JEP155 states that 500-V HBM allows safe manufacturing with a standard ESD control process.
- (2) JEDEC document JEP157 states that 250-V CDM allows safe manufacturing with a standard ESD control process.

### 6.3 Recommended Operating Conditions

over operating free-air temperature range (unless otherwise noted)

		MIN	MAX	UNIT
V <sub>CC</sub>	Collector-emitter voltage (non-V devices)	0	50	V
T <sub>J</sub>	Junction temperature	-40	125	°C

### 6.4 Thermal Information

THERMAL METRIC <sup>(1)</sup>	ULx200x				UNIT	
	D (SOIC)	N (PDIP)	NS (SO)	PW (TSSOP)		
	16 PINS	16 PINS	16 PINS	16 PINS		
R <sub>θJA</sub>	Junction-to-ambient thermal resistance	73	67	64	108	°C/W
R <sub>θJC(top)</sub>	Junction-to-case (top) thermal resistance	36	54	n/a	33.6	°C/W
R <sub>θJB</sub>	Junction-to-board thermal resistance	n/a	n/a	n/a	51.9	°C/W
ψ <sub>JT</sub>	Junction-to-top characterization parameter	n/a	n/a	n/a	2.1	°C/W
ψ <sub>JB</sub>	Junction-to-board characterization parameter	n/a	n/a	n/a	51.4	°C/W

- (1) For more information about traditional and new thermal metrics, see the *Semiconductor and IC Package Thermal Metrics* application report, [SPRA953](#).

## 6.5 Electrical Characteristics: ULN2002A

 $T_A = 25^\circ\text{C}$ 

PARAMETER	TEST FIGURE	TEST CONDITIONS	ULN2002A			UNIT
			MIN	TYP	MAX	
$V_{I(on)}$ ON-state input voltage	Figure 14	$V_{CE} = 2\text{ V}$ , $I_C = 300\text{ mA}$			13	V
$V_{OH}$ High-level output voltage after switching	Figure 18	$V_S = 50\text{ V}$ , $I_O = 300\text{ mA}$	$V_S - 20$			mV
$V_{CE(sat)}$ Collector-emitter saturation voltage	Figure 12	$I_I = 250\ \mu\text{A}$ , $I_C = 100\text{ mA}$		0.9	1.1	V
		$I_I = 350\ \mu\text{A}$ , $I_C = 200\text{ mA}$		1	1.3	
		$I_I = 500\ \mu\text{A}$ , $I_C = 350\text{ mA}$		1.2	1.6	
$V_F$ Clamp forward voltage	Figure 15	$I_F = 350\text{ mA}$		1.7	2	V
$I_{CEX}$ Collector cutoff current	Figure 9	$V_{CE} = 50\text{ V}$ , $I_I = 0$			50	$\mu\text{A}$
	Figure 10	$V_{CE} = 50\text{ V}$ , $T_A = 70^\circ\text{C}$ , $V_I = 6\text{ V}$			100 500	
$I_{I(off)}$ OFF-state input current	Figure 10	$V_{CE} = 50\text{ V}$ , $I_C = 500\ \mu\text{A}$	50	65		$\mu\text{A}$
$I_I$ Input current	Figure 11	$V_I = 17\text{ V}$		0.82	1.25	mA
$I_R$ Clamp reverse current	Figure 14	$V_R = 50\text{ V}$ , $T_A = 70^\circ\text{C}$			100	$\mu\text{A}$
		$V_R = 50\text{ V}$			50	
$C_i$ Input capacitance		$V_I = 0$ , $f = 1\text{ MHz}$			25	pF

## 6.6 Electrical Characteristics: ULN2003A and ULN2004A

 $T_A = 25^\circ\text{C}$ 

PARAMETER	TEST FIGURE	TEST CONDITIONS	ULN2003A			ULN2004A			UNIT
			MIN	TYP	MAX	MIN	TYP	MAX	
$V_{I(on)}$ ON-state input voltage	Figure 14	$V_{CE} = 2\text{ V}$	$I_C = 125\text{ mA}$					5	V
			$I_C = 200\text{ mA}$			2.4		6	
			$I_C = 250\text{ mA}$			2.7			
			$I_C = 275\text{ mA}$					7	
			$I_C = 300\text{ mA}$			3			
			$I_C = 350\text{ mA}$					8	
$V_{OH}$ High-level output voltage after switching	Figure 18	$V_S = 50\text{ V}$ , $I_O = 300\text{ mA}$	$V_S - 20$			$V_S - 20$			mV
$V_{CE(sat)}$ Collector-emitter saturation voltage	Figure 13	$I_I = 250\ \mu\text{A}$ , $I_C = 100\text{ mA}$		0.9	1.1	0.9	1.1	V	
		$I_I = 350\ \mu\text{A}$ , $I_C = 200\text{ mA}$		1	1.3	1	1.3		
		$I_I = 500\ \mu\text{A}$ , $I_C = 350\text{ mA}$		1.2	1.6	1.2	1.6		
$I_{CEX}$ Collector cutoff current	Figure 9	$V_{CE} = 50\text{ V}$ , $I_I = 0$			50		50	$\mu\text{A}$	
	Figure 10	$V_{CE} = 50\text{ V}$ , $T_A = 70^\circ\text{C}$ , $V_I = 6\text{ V}$			100		100 500		
$V_F$ Clamp forward voltage	Figure 16	$I_F = 350\text{ mA}$		1.7	2		1.7	2	V
$I_{I(off)}$ Off-state input current	Figure 11	$V_{CE} = 50\text{ V}$ , $T_A = 70^\circ\text{C}$ , $I_C = 500\ \mu\text{A}$	50	65		50	65	$\mu\text{A}$	
$I_I$ Input current	Figure 12	$V_I = 3.85\text{ V}$		0.93	1.35			mA	
		$V_I = 5\text{ V}$				0.35	0.5		
		$V_I = 12\text{ V}$				1	1.45		
$I_R$ Clamp reverse current	Figure 15	$V_R = 50\text{ V}$			50		50	$\mu\text{A}$	
		$V_R = 50\text{ V}$ , $T_A = 70^\circ\text{C}$			100		100		
$C_i$ Input capacitance		$V_I = 0$ , $f = 1\text{ MHz}$		15	25		15	25	pF

## 6.7 Electrical Characteristics: ULN2003AI

T<sub>A</sub> = 25°C

PARAMETER	TEST FIGURE	TEST CONDITIONS	ULN2003AI			UNIT
			MIN	TYP	MAX	
V <sub>I(on)</sub> ON-state input voltage	Figure 14	V <sub>CE</sub> = 2 V	I <sub>C</sub> = 200 mA		2.4	V
			I <sub>C</sub> = 250 mA		2.7	
			I <sub>C</sub> = 300 mA		3	
V <sub>OH</sub> High-level output voltage after switching	Figure 18	V <sub>S</sub> = 50 V, I <sub>O</sub> = 300 mA	V <sub>S</sub> – 50			mV
V <sub>CE(sat)</sub> Collector-emitter saturation voltage	Figure 13	I <sub>I</sub> = 250 μA, I <sub>C</sub> = 100 mA	0.9	1.1	V	
		I <sub>I</sub> = 350 μA, I <sub>C</sub> = 200 mA	1	1.3		
		I <sub>I</sub> = 500 μA, I <sub>C</sub> = 350 mA	1.2	1.6		
I <sub>CEX</sub> Collector cutoff current	Figure 9	V <sub>CE</sub> = 50 V, I <sub>I</sub> = 0		50	μA	
V <sub>F</sub> Clamp forward voltage	Figure 16	I <sub>F</sub> = 350 mA	1.7	2	V	
I <sub>I(off)</sub> OFF-state input current	Figure 11	V <sub>CE</sub> = 50 V, I <sub>C</sub> = 500 μA	50	65	μA	
I <sub>I</sub> Input current	Figure 12	V <sub>I</sub> = 3.85 V	0.93	1.35	mA	
I <sub>R</sub> Clamp reverse current	Figure 15	V <sub>R</sub> = 50 V		50	μA	
C <sub>i</sub> Input capacitance		V <sub>I</sub> = 0, f = 1 MHz	15	25	pF	

## 6.8 Electrical Characteristics: ULN2003AI

T<sub>A</sub> = –40°C to 105°C

PARAMETER	TEST FIGURE	TEST CONDITIONS	ULN2003AI			UNIT
			MIN	TYP	MAX	
V <sub>I(on)</sub> ON-state input voltage	Figure 14	V <sub>CE</sub> = 2 V	I <sub>C</sub> = 200 mA		2.7	V
			I <sub>C</sub> = 250 mA		2.9	
			I <sub>C</sub> = 300 mA		3	
V <sub>OH</sub> High-level output voltage after switching	Figure 18	V <sub>S</sub> = 50 V, I <sub>O</sub> = 300 mA	V <sub>S</sub> – 50			mV
V <sub>CE(sat)</sub> Collector-emitter saturation voltage	Figure 13	I <sub>I</sub> = 250 μA, I <sub>C</sub> = 100 mA	0.9	1.2	V	
		I <sub>I</sub> = 350 μA, I <sub>C</sub> = 200 mA	1	1.4		
		I <sub>I</sub> = 500 μA, I <sub>C</sub> = 350 mA	1.2	1.7		
I <sub>CEX</sub> Collector cutoff current	Figure 9	V <sub>CE</sub> = 50 V, I <sub>I</sub> = 0		100	μA	
V <sub>F</sub> Clamp forward voltage	Figure 16	I <sub>F</sub> = 350 mA	1.7	2.2	V	
I <sub>I(off)</sub> OFF-state input current	Figure 11	V <sub>CE</sub> = 50 V, I <sub>C</sub> = 500 μA	30	65	μA	
I <sub>I</sub> Input current	Figure 12	V <sub>I</sub> = 3.85 V	0.93	1.35	mA	
I <sub>R</sub> Clamp reverse current	Figure 15	V <sub>R</sub> = 50 V		100	μA	
C <sub>i</sub> Input capacitance		V <sub>I</sub> = 0, f = 1 MHz	15	25	pF	